

## Welding Positioners

### Standard Features:

- Foot control-ON/OFF
- Contactor control
- Speed control
- Timer control



PT-101



PT-201

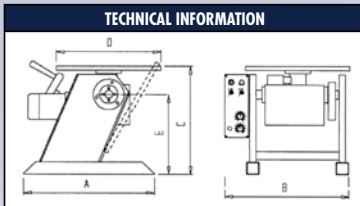

MODEL	UNIT	PT-101A	PT-101D	PT-201A	PT-101D
POWER INPUT	-	1 Phase 110/220V 50/60Hz			
HORIZONTAL CAPACITY	lb	220		440	
VERTICAL CAPACITY	lb	165		330	
RATED CENTER OF GRAVITY	in	2 (Max)			
RATED ECCENTRICITY	in	4 (Max)			
TABLE DIMENSION	in	12-5/8			
ROTATION SPEED	rpm	0.55~4	1~16	0.55~4	1~16
ROTATION TORQUE	lb-in	570	145	960	240
ROTATION RATING @ ECCENTRIC CG	lb@in	130lb@1 inch	130lb@1 inch	280lb@1 inch	240lb@1 inch
		130lb@2 inch	70lb@2 inch	280lb@2 inch	120lb@2 inch
		130lb@4 inch	35lb@4 inch	140lb@4 inch	60lb@4 inch
		70lb@8 inch	15lb@8 inch	120lb@8 inch	30lb@8 inch
		45lb@12 inch	10lb@12 inch	80lb@12 inch	20lb@12 inch
		20lb@44 inch	5lb@24 inch	40lb@24 inch	10lb@24 inch
SPINDLE THRU HOLE	in	1-1/2			
TABLE SLOT BOLT SIZE	in	3/8			
EARTHING CAPACITY	amp	300			
ROTATION MOTOR	hp	1/20		1/12	
TILT RANGE	degree	0-120			
OVER HUNG LOAD TILT RATING @ ECCENTRIC CG	lb@in	130lb@4 inch		280lb@4 inch	
		65lb@8 inch		140lb@8 inch	
		30lb@12 inch		90lb@12 inch	
		15lb@24 inch		45lb@24 inch	
WELDING TIMER	second	0-60			
OVERALL LENGTH (A)	in	16-1/4			
OVERALL WIDTH (B)	in	16-1/4			
OVERALL HEIGHT (C)	in	13-3/8			
TABLE TOP DIAMETER DIMENSION (D)	in	12-1/2			
CENTER TO FLOOR (E)	in	10			
NET WEIGHT	lb	75		80	

Specifications subject to change without prior notice.

# Benchmatic E·Z·ARC SYSTEMS

## Welding Positioners Turning Rolls



## Turning Rolls

### \*TR-0100

- The DC drive P.C. board is protected against high-frequency interference
- Remote foot switch ON/OFF controller
- Designed for various small welding applications and long production runs
- **Forward/Stop/Reverse** switch
- Foot control-ON/OFF
- Speed control

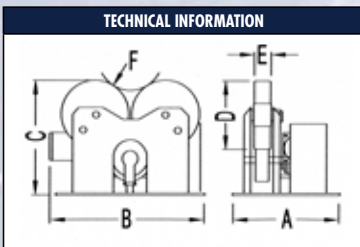

(Optional Idler roll sets available)

ITEM	*TR-0100
POWER INPUT	1 PHASE 110/220V
TURNING CAPACITY(lb)	2200
LOAD CAPACITY(lb) (DRIVE & IDLER)	2200
DIAMETER RANGE, F(in)	1 ~ 31-3/8
SPEED RANGE (in/min)	3 ~ 63
ROTATION MOTOR(hp)	1/12
ROLLER DIA., D(in)	8
ROLLER WIDTH, E(in)	2
OVERALL LENGTH, A(in) (DRIVE/IDLER)	12-5/8 / 6-5/16
OVERALL WIDTH, B(in) (DRIVE/IDLER)	18-1/2 / 17-3/4
OVERALL HEIGHT, C(in)	13-5/16
NET WEIGHT(lb) (DRIVE/IDLER)	81.5/37.5

\*TR-0100 is not compatible with standard DIY Accessories Kits.

Visit our website for complete offering:  
Welding Positioners, Manipulators, Head & Tail Stock Assembly, Turntables,  
Welding Lathes, Seamers, Coil Splicers, Turning Roll Sets, CNC-Cutting Machines

[www.genstartech.com](http://www.genstartech.com)

[www.genstartech.com](http://www.genstartech.com)

**Genstar Technologies Company, Inc.**  
4525 Edison Avenue, Chino, CA 91710  
Tel 909-606-2726 • Fax 909-606-6485



## E•Z•Arc System

E•Z•Arc System is a combination of Positioner and DIY Accessories Kit in bench design. A wide choice of components creates great flexibility in the automatic welding system. Components are easy to change to minimize the setup time. The special capability of E•Z•Arc System produces high quality circumferential welds, and provides the advantage of fast pay-back, safety and less worker fatigue.

### E•Z•Arc System features:

- CE Conformity
- Standard  $\phi 1.5"$  through-hole
- Remote foot switch - ON/OFF Controller
- All units are high frequency protected
- Weld timer control for precise adjustment of the welding period
- Heat and spatter resistant air hose
- Optional Flange-Adapting Fixture (10-613) with bearing of any required fixture
- Optional CB002 overweld control
- Optional CB007 sequencer control
- Optional Pneumatic torch holders

Easy to order - Just order the Positioner, DIY Kit & Accessories as needed.

STANDARD SPEED RANGES	
"A Range" (Low Speed - High Torque)	
"D Range" (High Speed - Low Torque)	
PT-101 - 220lbs	
PT-201 - 440lbs	
A - MIG, TIG, Plasma	
D - High Speed Thin Wall MIG	
DIY Accessories Kits	
DIY-U-06	U Type, 24" L
DIY-S-06	S Type, 24" L
DIY-R-12	R Type, 48" L
DIY-R-15	R Type, 60" L
DIY-R-18	R Type, 72" L
DIY-L-12	L Type, 48" L
DIY-L-15	L Type, 60" L
DIY-L-18	L Type, 72" L

System Features

DIY Accessories Kits

## DIY Accessories Kits

Compatible with PT-102 or PT-202 Digital Positioner and CB-007-1 PLC Programmable Controller



U-Type

R-Type

S-Type

L-Type

- Models shown above are with Positioners and 3-Jaw Chucks.
- Positioners and 3-Jaw Chucks are not part of the DIY Accessories Kits.
- R AND L type kits available (48", 60", 72" mounting rails.
- L-kit approx max part length is 20" with 48" mounting rail.

## DIY Accessories Kit Components and Optional Accessories

**PT-101 Positioner**  
Manual table angle adjustment with locking screw



**PT-201 Positioner**  
Table angle adjustment with worm gears and crank handle



### Positioners Standard Features:

- Remote foot switch with ON/OFF control
- Speed control
- Timer
- Contractor control circuit

### Speed range gear box field kits

- Easy four bolt installation:
- 0351-0109 (Speed Range:A) 0.15 - 4 RPM
  - \*0351-0115 (Speed Range:B) 0.3 - 8 RPM
  - \*0351-0122 (Speed Range:C) 0.4 - 12 RPM
  - 0351-0129 (Speed Range:D) 0.55 - 16 RPM

E•Z•ARC DIY Accessories Kit Components											
Fig. No.	Model No.	Description/Specification	DIY -								
			U-06	S-06	R-12	R-15	R-18	L-12	L-15	L-18	
1	1106	Base Rail, 24" long		1							
	1112	Base Rail, 48" long			1			1			
	1115	Base Rail, 60" long				1			1		
	1118	Base Rail, 72" long					1			1	
	4095	Main Bracket for U Type	1								
2	2050	Mounting Rail, 20" long		1	1	1	1	1	1	1	1
	2065	Mounting Rail, 26" long	1								
3	2110	End Bracket		1	1	1	1	1	1	1	1
	2280	End Bracket	1								
4	3064	90° Column Tube, 24"x16"	1								
	3075	Column Tube, 30" long		1	1	1	1	1	1	1	1
5	2005	Support Bracket		1	1	1	1	1	1	1	1
	2004	Support Bracket	1								
6	2044	Cross Bracket	1								
	2054	Cross Bracket		1	1	1	1	1	1	1	1
7	3040	Boom Tube with mounting pad, 16" long	1	1	1	1	1	1	1	1	
8	TS-075	Tailstock, 3" stroke, w/Std 10-614							1	1	1
	TS-075S	Tailstock, 3" stroke, w/Std 10-614	1								
9	10-614	Standard Fixture with Bearing	1						1	1	1
10	IS-300	Idler Stand for R Type, 1-3/16"-11-13/16"			1	1	1				
11	SL-050	Slide, 2" stroke	2	2	2	2	2	2	2	2	2
12	VH-035	V-Block Torch Holder, $\phi 5/8"$ -1-3/8"	1	1	1	1	1	1	1	1	1

E•Z•ARC Optional Accessories			
11	SL-075	Slide, 3" stroke	<p><b>*CONTROL BOXES</b></p> <p><b>CB-001 Standard Control:</b></p> <ul style="list-style-type: none"> <li>• Remote Foot Switch with ON/OFF control</li> <li>• Contractor control (foot switch closes circuit)</li> <li>• Speed, &amp; Time Adjustment</li> </ul> <p><b>Optional Control Boxes:</b></p> <p><b>CB-002 Standard Control Plus Weld Travel Control</b> Weld Travel Control with magnetic proximity switch:</p> <ul style="list-style-type: none"> <li>• 0-5 sec travel start delay, speed control, weld travel control 360° to 400° &amp; return to original starting position by sensor setting</li> </ul> <p><b>CB-007 Standard Control Plus Sequencer</b> Sequencer Adjustable timers:</p> <ul style="list-style-type: none"> <li>• Initiate pneumatic Tail Stock &amp; Torch Holders</li> <li>• Standard speed, time, &amp; contractor controls</li> <li>• Retraction of pneumatic Tail Stock &amp; Torch Holders</li> </ul> <p><b>CB-001V Factory Variable Speed Kit</b> <b>CB-001VF Field Variable Speed Kit</b> The variable speed kit maintains all of the Standard Control Features. Plus the ability to use a Foot Control for variable speed of the full range.</p>
12	AH-035	Any Angle Holder, $\phi 5/8"$ -1-3/8"	
13	PG-150	3-Jaw Chuck, OD 3/16"-6"	
	PG-500	3-Jaw Chuck, OD 3/16"-19-5/8"	
14	TA-100	Pneumatic Torch Actuator, 4" Stroke	
	TL-100	Pneumatic Torch Lift, 22.5" Lift Angle	
15	*CB-002	Sequencer Control Box	
	*CB-007	Sequencer Control Box	
16	1712	Welding Table, 47" x 24"	
	1715	Welding Table, 59" x 24"	
	1718	Welding Table, 71" x 24"	
17	10-613	Flange-Adapting Fixture with Bearing	

## DIY Accessories Kit Components

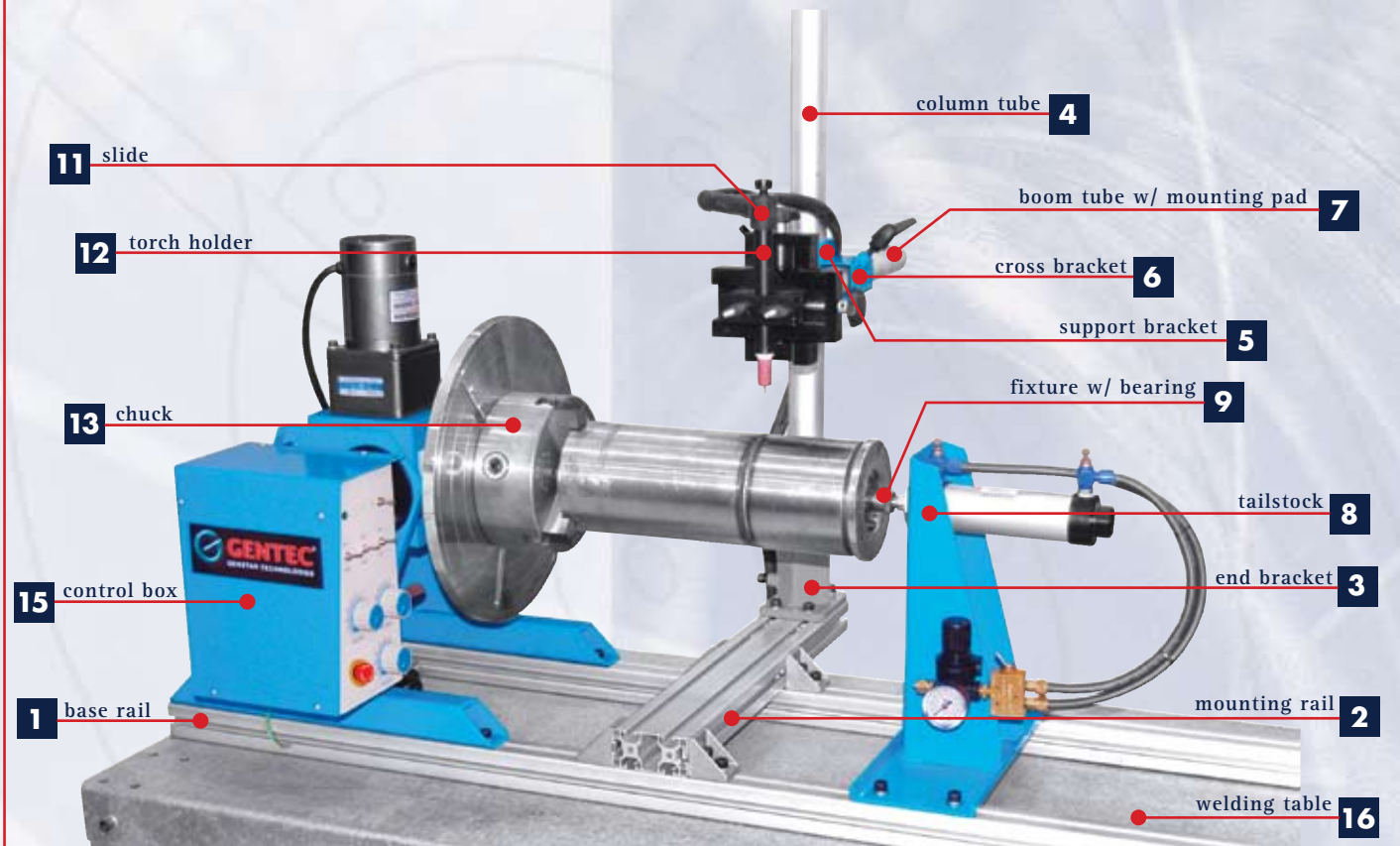

Order as shown in the Figure: one DIY-L12 L-Type Accessories Kit, one PT-100A Positioner, one PG-150 3-Jaw Chuck, one 1712 Welding Table (47"x24"). Welding Torch is not included.

## Optional Accessories



Torch Slide



Torch Lift



Idler Stand

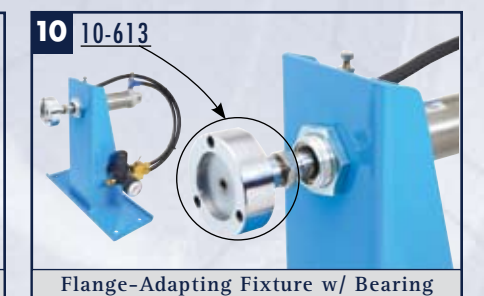

Flange-Adapting Fixture w/ Bearing

(Welding Torch, Slide, Column and Boom are not included)