



SPECIALTY GAS REGULATORS & ACCESSORIES

Regulators • Pressure Gauges • Valves • Filters • Special Applications

Technology for a Better Future

TABLE OF CONTENTS

GENTEC® Specialty Gas Products

Specialty Gas Equipment

01. **Company Overview**
02. **Regulator Port Components**
03. **Selecting GENTEC® Gas Regulators**
04. **Regulator Family**



05.-14. General Purpose Forged Brass Regulators

05. G152 General Purpose, Medium Flow Regulator
07. G152T General Purpose, Medium Flow Regulator
09. HP152L High Purity, Medium Flow Line Regulator
11. HP152 High Purity, Medium Flow Regulator
13. HP152T High Purity, Medium Flow Regulator



15.-22. High Purity Brass Barstock Regulators

15. R21B High Purity, Low Flow Line Regulator
17. R21B High Purity, Low Flow Regulator
19. R22B High Purity, Medium Flow Line Regulator
21. R31B High Purity, Low Flow Regulator



23.-30. High Purity Stainless Steel Barstock Regulators

23. R21SL High Purity, Low Flow Line Regulator
25. R21SL High Purity, Low Flow Regulator
27. R22SL High Purity, Medium Flow Line Regulator
29. R31SL High Purity, Low Flow Regulator



31.-38. Special Applications

- 31. R44SL High Purity, High Pressure Low Flow Regulator
- 33. R45SL Ultra High Pressure, Low Flow Regulator
- 35. R51SL Corrosion Resistant, Low Flow Regulator
- 37. R77SL Back Pressure, Low Flow Regulator



39.-46. Ultra High Purity Regulators

- 39. U21SL Series, Ultra High Purity, Medium Flow Regulator
- 41. U22SL Series, Ultra High Purity, High Flow Regulator
- 43. U23SL Series, Ultra High Purity, High Flow Regulator
- 45. U53SL Series, Ultra High Purity, Low Flow Regulator



47.-54. Accessories

- 47. Regulator Protocol Station and Gauges
- 49. Valves and Filters
- 51. Purge Tools and Fittings
- 53. Cylinder Connections and Brackets

55. Materials of Construction

56.-60. Gas Service

61. Material Compatibility

62. Allocation Table

63. Warranty Information

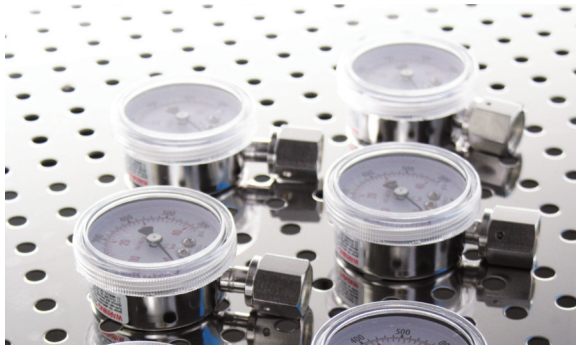

Company Overview

Genstar Technologies is a global leader in Gas Flow Control Systems for the industrial, specialty gas and medical sectors. We pride ourselves in our ability to provide our customers with high quality, value-added products and services that go beyond the industry standards. As a result, we have a global network of thousands of satisfied customers in over 60 countries.

Our Team

Our highly educated team of engineers, salespeople, technicians, managers, and customer service personnel are dedicated to providing you with products with the highest quality, reliability and performance. We hold the highest standards to our manufacturing processes; our total process management maximizes our production efficiency while ensuring product quality.

We work closely with all of our customers to design products specific to your needs. This includes developing new products, redesigning existing products, and customizing configuration / packaging. It is our priority to foster a strong relationship with each and every customer.

Quality Assurance

All of our products are manufactured under stringent quality control. We are ISO 9001:2001, ISO13485, and API certified. Our products meet UL, CE, SEMI, and various international standards and certifications.

Manufacturing Capabilities

The manufacturing facility is equipped with CNC machines, electro-polishing equipment, and precision automated orbital welding systems, among other features, to ensure the production of the highest quality products.

Clean Room Facilities

Our class 10/100/1000 clean rooms are designed for Ultra High Purity (UHP) products. UHP products undergo precision machining, surface finishing, electro-polishing and passivation. All UHP products are cleaned by 18MΩ DI water in a cascade ultrasonic tank. To ensure the highest UHP product quality, they are then vacuum-dried and double-bagged.



Regulator Port Configurations

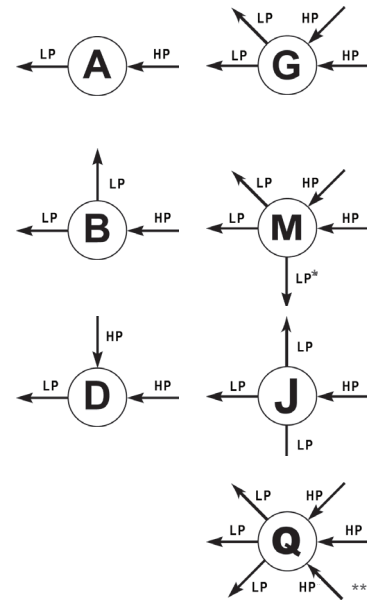

** For R31 Series, this high pressure “Q” port configuration is plugged. This port can be used for purging purpose only.

* For the “M” port configuration of R31 Series, this port is plugged and cannot be used for relief valve installation.

1. Inlet (High) Pressure Gauge

- Fabricated from German imported Bourdon tubes
- High accuracy and stability

2. Inlet Connection

- Multiple connections available
- Compliant with CGA/BSP/DIN/JIS/GB standards

3. Safety Valve

- Accurate relief of pressure
- Reliable and positive shut-off

4. Outlet Connection

- Multiple connections available

5. Outlet (Low) Pressure Gauge

- Fabricated from German imported Bourdon tubes
- High accuracy and stability

6. Regulator Body

- Fabricated from high-strength corrosion-resistant material
- Fabricated with advanced CNC machines to produce the highest quality of parts
- Wetted area are polished to ensure a clean and smooth flow
- 316L & Hastelloy diaphragms produce a metal-to-metal, leak-proof seal

7. Diaphragm Valve

- Designed to withstand temperature and vibration fluctuations
- Assure a consistent outlet flow
- Ergonomically designed control knob for easy adjustment

Note: Please consult the GENTEC® facility about special port configurations or requests.

Gas Service and Material Compatibility

1. Assess the gas application against the material of construction of the regulator.
2. Regulator components that come into contact with the gas stream called “wetted surfaces” should be compatible with the intended gas service.
3. CGA connections are determined by gas usage. Please refer to the “Cylinder Connection Table,” on page 56 for the recommended connection.

Gas Purity

High Purity grade gases will require more “diffusion resistant” components than lower purity grade gases. Diffusion means that gases can either desorb or adsorb from the seat or diaphragm material of the regulator resulting in impurity contamination of the gas stream. Stainless Steel diaphragms should also be used since Elastomeric (rubber-based) diaphragms tend to absorb and outgas and they can compromise gas purity.

Outlet Connections

Specific outlet connections are determined by usage, flow, and pressure requirements. Most regulators are available with custom fittings and configured at the time of ordering. GENTEC® offers a wide range of outlet fittings in addition to hose connections, needle and diaphragm valves, and tube fittings.

Single vs. Dual Stage

Single-Stage Regulators reduce pressure by passing through a pressure reducing valve area in one step to deliver a pressure within a specific range. These regulators demonstrate a slight increase in delivery pressure as the cylinder pressure falls during use, also known as “Inlet Pressure Decay.” This reduced Inlet Pressure Decay provides less force against the regulator valve causing it to open wider resulting in increased outlet pressure.

Dual-Stage Regulators perform a similar function as Single-Stage Regulators. The Dual-Stage Regulator delivery pressure remains constant as the cylinder pressure decreases. However, greater accuracy in pressure control is maintained because the pressure is reduced by passing through two pressure reducing valves instead of one. The first stage reduces the incoming high pressure into the second stage. The second stage then reduces the remaining pressure to the desired working pressure. Because the inlet pressure on the second stage is relatively stable from the first stage, Dual-Stage Regulators maintain constant delivery pressure and do not require periodic adjustment as the cylinder pressure decreases.

In summary, for a Single-Stage Regulator, the outlet pressure may increase as the cylinder pressure drops. In a Dual-Stage Regulator, the outlet pressure should remain constant as the cylinder pressure drops.

**GENTEC®
GENERAL
PURPOSE
REGULATORS**

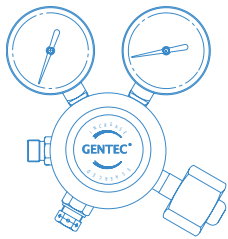

1

Recommended for use with inert and non-corrosive pure and mixed gas applications where elastomeric outgassing is not critical.

These regulators are not recommended for analytical or high purity applications. Typical applications include general laboratory or plant use. GENTEC® regulators can provide safety relief valves to protect downstream equipment from over-pressurization. Needle and Diaphragm Valves on the outlet are also available.

**GENTEC®
HIGH
PURITY
REGULATORS**

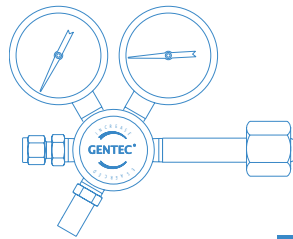

2

Recommended for use with inert, flammable, and semi-corrosive pure and mixed gas applications.

Typical applications include GC analytical instrumentation, chromatographic carrier gas, and process gas regulation. These units minimize outgassing and inboard diffusion through the use of stainless steel convoluted diaphragms, high purity seats and seal rings.

**GENTEC®
ULTRA & HIGH
PURITY
CORROSION
RESISTANT
REGULATORS**

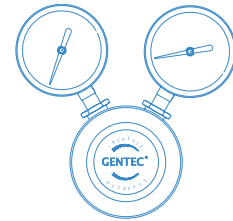

3

Recommended for use with semi-corrosive and some toxic applications.

The stainless steel convoluted metal-to-metal diaphragm seal provides superior leak performance and eliminates the need for seal rings. This metal-to-metal seal eliminates outgassing and inboard diffusion in the gas stream.

G152 SERIES

General Purpose Medium Flow Regulator

Specialty Gas Equipment



» **G152-DKK-C320-01-NR**

Materials

- | | |
|------------------|----------------------------|
| • Body | Forged Brass |
| • Bonnet | Nickel-Plated Forged Brass |
| • Seat | PU |
| • Diaphragm | Neoprene |
| • Seal | Nylon |
| • Adjusting Knob | ABS plastic |

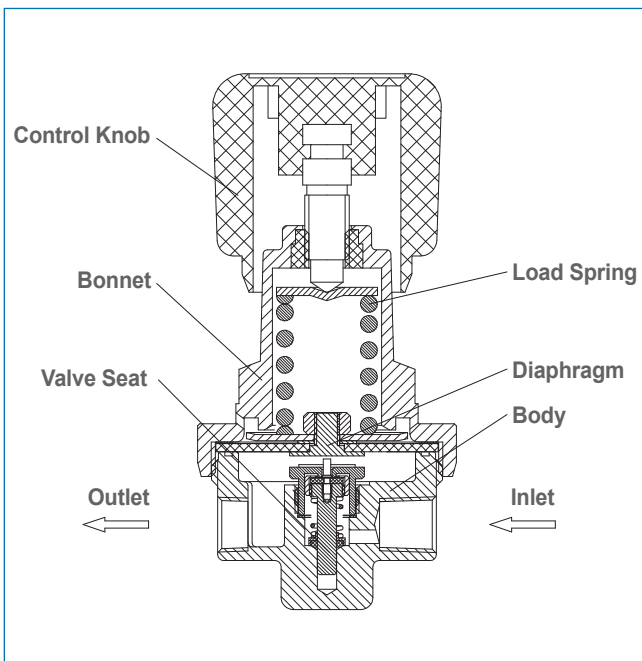

GENTEC® G152 Series is a Single-Stage Brass Regulator designed for General Purpose laboratory applications where occasional readjustment of the working pressure is acceptable.

Not recommended for high purity application in which outgassing due to elastomeric components would adversely affect the process.

Product Features

- 2" Neoprene Diaphragm
- 2" Dual-Scale Pressure Gauges in gold steel casing
- Optional outlet: Needle Valve or Diaphragm Valve
- Conforms to CGA E-4 standard for Gas Pressure Regulators

Applications

- Non-Corrosive Gases
- Purging
- Leak Testing
- Gas Shielding

Specifications

- Maximum inlet pressure: 3000 psig
- Maximum outlet pressure: 250 psig
- Operating temperature range: 0 to 140°F (-17 to 60°C)
- Weight: 3 lb 2 oz

Dimensions

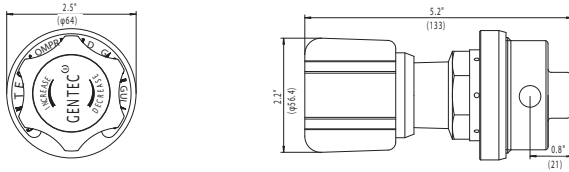

Flow Data

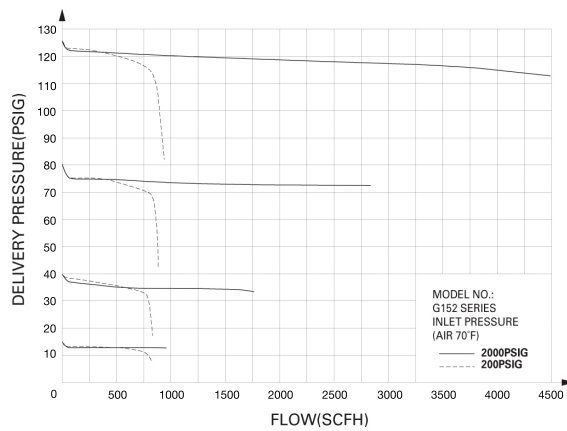

Ordering Information

EX: G152- Series	D Inlet Pressure Range	K Outlet Pressure Ranges	K - Gauge	C320 - Inlet Connections	01 - Outlet Connections	NR Options
• G152	D: 3000 psig	G: 0-250 psig H: 0-150 psig I: 0-100 psig K: 0-50 psig M: 0-15 psig	K: Gauge W: No Gauge	00: 1/4" NPT(F) C346: CGA346 C320: CGA320 C350: CGA350 C510: CGA510 C540: CGA540 C580: CGA580 C590: CGA590 C326: CGA326 Other connections available	00: 1/4" NPT(F) 01: 1/4" NPT(M) 10: 1/8" GENLOK 11: 1/4" GENLOK 14B: 1/4" Hose Barb Other connections available	Blank: None D: Diaphragm Valve N: Needle Valve R: Relief Valve

G152T SERIES

General Purpose Medium Flow Regulator

Specialty Gas Equipment



» G152T-DGK-C540-01-NR

Materials

- | | |
|------------------|----------------------------|
| • Body | Forged Brass |
| • Bonnet | Nickel-Plated Forged Brass |
| • Seat | PU |
| • Diaphragm | Neoprene |
| • Seal | Nylon |
| • Adjusting Knob | ABS plastic |

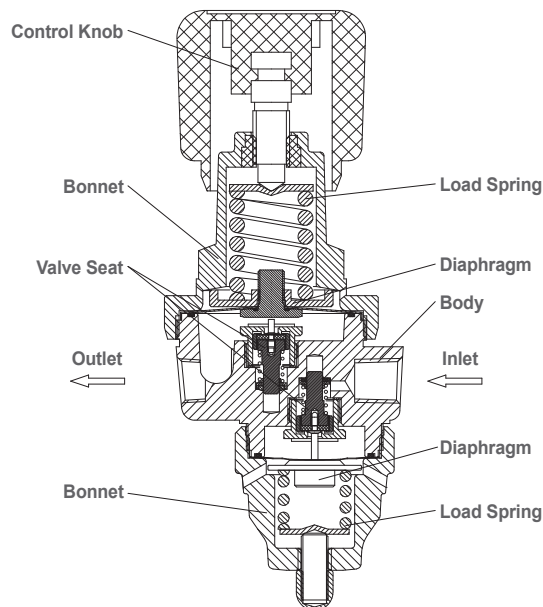

GENTEC® G152T Series is a Dual-Stage Brass Regulator designed for General Purpose laboratory applications where continuous outlet flow and pressure are desired.

Not recommended for high purity application in which outgassing due to elastomeric components would adversely affect the process.

Product Features

- Neoprene Diaphragm: 1-1/4" for Single-Stage, 2" for Dual-Stage
- 2" Dual-Scale Pressure Gauges in gold steel casing
- Optional outlet: Needle Valve or Diaphragm Valve
- Conforms to CGA E-4 standard for Gas Pressure Regulators

Applications

- Non-Corrosive Gases
- Purging
- Leak Testing
- Gas Shielding

Specifications

- Maximum inlet pressure: 3000 psig
- Maximum outlet pressure: 250 psig
- Operating temperature range: 0 to 140°F (-17 to 60°C)
- Weight: 4 lb 1 oz

Dimensions

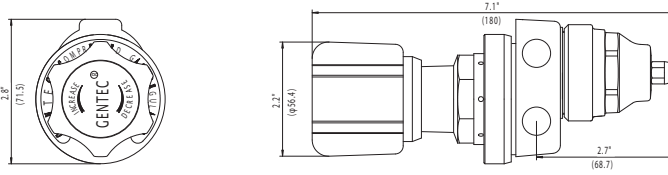

Flow Data

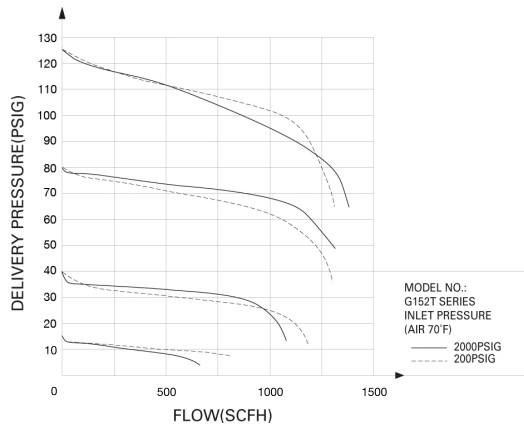

Ordering Information

EX: G152T-Series	D Inlet Pressure Range	G Outlet Pressure Ranges	K - Gauge	C540 - Inlet Connections	01 - Outlet Connections	NR Options
• G152T	D: 3000 psig	G: 0-250 psig H: 0-150 psig I: 0-100 psig K: 0-50 psig M: 0-15 psig	K: Gauge W: No Gauge	00: 1/4" NPT(F) C346: CGA346 C320: CGA320 C350: CGA350 C510: CGA510 C540: CGA540 C580: CGA580 C590: CGA590 C326: CGA326 C500: CGA500 Other connections available	00: 1/4" NPT(F) 01: 1/4" NPT(M) 10: 1/8" GENLOK 11: 1/4" GENLOK 14B: 1/4" Hose Barb Other connections available	D: Diaphragm Valve N: Needle Valve R: Relief Valve

HP152L SERIES

High Purity Medium Flow Line Regulator

Specialty Gas Equipment



» **HP152L-FHK-11-11**

GENTEC® HP152L Series is a Single-Stage High Purity Brass Line Regulator designed for High Purity applications where occasional readjustment of the working pressure is acceptable.

Not recommended for corrosive gases.

Product Features

- 2" 316L Stainless Steel Diaphragm
- 2" Dual-Scale Pressure Gauges
- Optional outlet: Needle Valve or Diaphragm Valve
- Conforms to CGA E-4 standard for Gas Pressure Regulators

Materials

- | | |
|------------------|----------------------------|
| • Body | Nickel-Plated Forged Brass |
| • Bonnet | Nickel-Plated Forged Brass |
| • Seat | PU |
| • Diaphragm | 316L Stainless Steel |
| • Adjusting Knob | ABS Plastic |

Applications

- Point of use pressure regulation

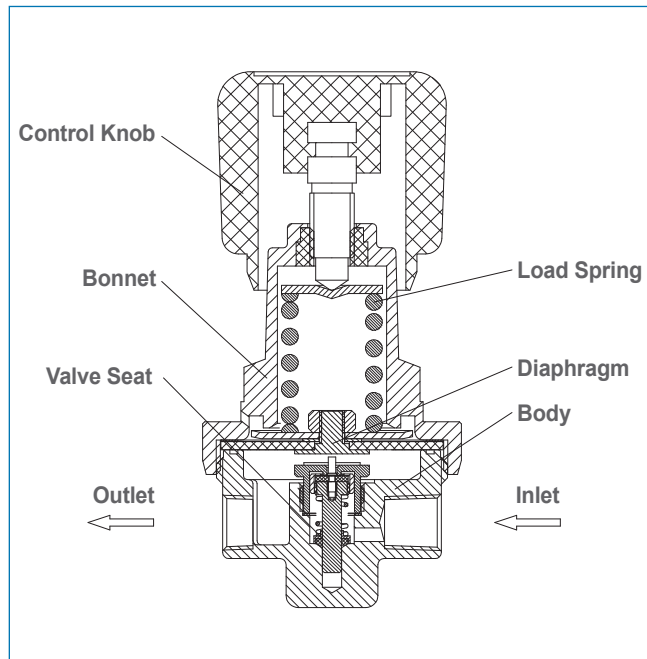

Specifications

- Maximum inlet pressure: 500 psig
- Maximum outlet pressure: 150 psig
- Operating temperature range: 0 to 140°F (-17 to 60°C)
- Weight: 3 lb 2 oz

Dimensions

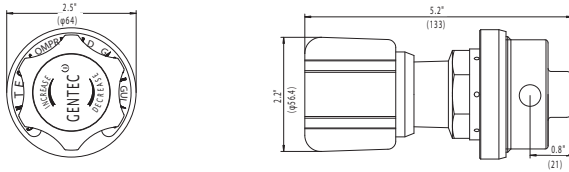

Flow Data

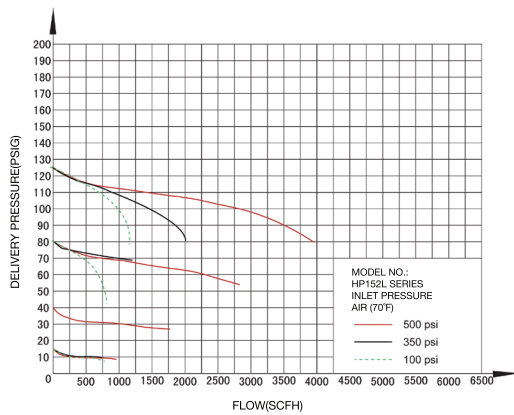

Ordering Information

EX: HP152L- Series	F Inlet Pressure Range	H Outlet Pressure Ranges	K - Gauge	11 - Inlet Connections	11 - Outlet Connections
• HP152L	F: 500 psig	H: 0-150 psig I: 0-100 psig K: 0-50 psig M: 0-15 psig	K: Gauge W: No Gauge	00: 1/4" NPT(F) 01: 1/4" NPT(M) 10: 1/8" GENLOK 11: 1/4" GENLOK 14B: 1/4" Hose Barb Other connections available	00: 1/4" NPT(F) 01: 1/4" NPT(M) 10: 1/8" GENLOK 11: 1/4" GENLOK 14B: 1/4" Hose Barb Other connections available

HP152 SERIES

High Purity Medium Flow Regulator

Specialty Gas Equipment



» HP152-DKK-C350-01-NR

Materials

- | | |
|------------------|----------------------------|
| • Body | Nickel-Plated Forged Brass |
| • Bonnet | Nickel-Plated Forged Brass |
| • Seat | PU |
| • Diaphragm | 316L Stainless Steel |
| • Adjusting Knob | ABS Plastic |

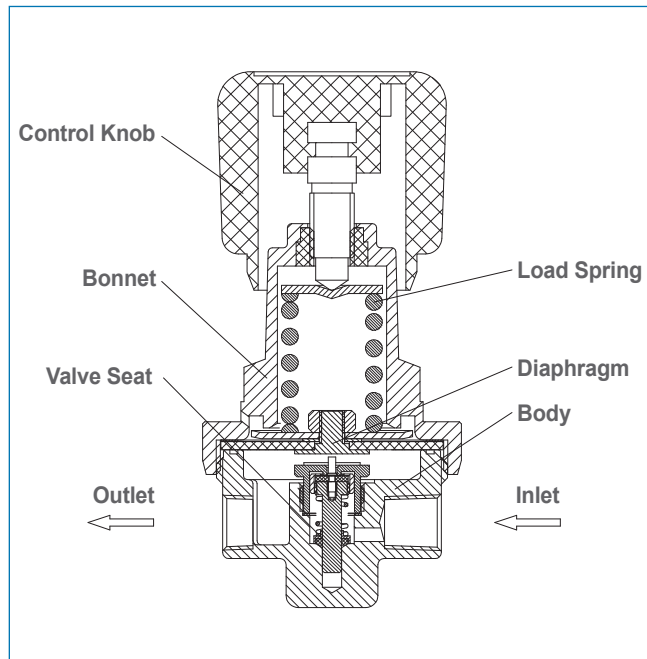

GENTEC® HP152 Series is a Single-Stage High Purity Brass Regulator designed for High Purity applications where occasional readjustment of the working pressure is acceptable.

Not recommended for corrosive gases.

Product Features

- 2" 316L Stainless Steel Diaphragm
- 2" Dual-Scale Pressure Gauges
- Optional outlet: Needle Valve or Diaphragm Valve
- Conforms to CGA E-4 standard for Gas Pressure Regulators

Applications

- Calibration of Pressures Gauges & Test Equipment
- Supply of carrier gases for Gas Chromatography

Specifications

- Maximum inlet pressure: 3000 psig
- Maximum outlet pressure: 250 psig
- Operating temperature range: 0 to 140°F (-17 to 60°C)
- Weight: 3 lb 2 oz

Dimensions

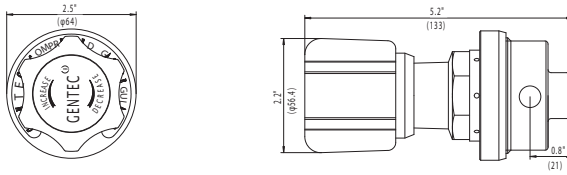

Flow Data

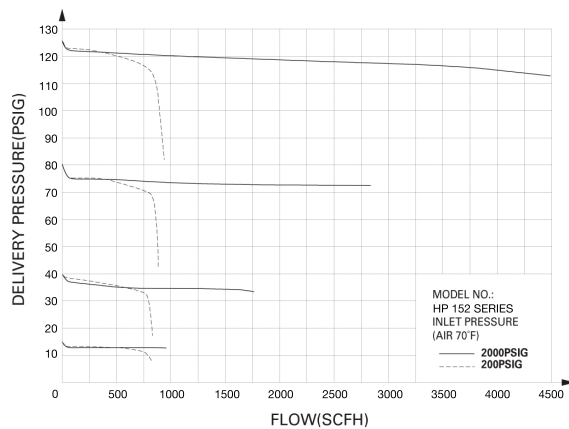

Ordering Information

EX: HP152- Series	D Inlet Pressure Range	K Outlet Pressure Ranges	K - Gauge	C350 - Inlet Connections	01 - Outlet Connections	NR Options
• HP152	D: 3000 psig	G: 0-250 psig H: 0-150 psig I: 0-100 psig K: 0-50 psig M: 0-15 psig	K: Gauge W: No Gauge	00: 1/4" NPT(F) C346: CGA346 C320: CGA320 C510: CGA510 C540: CGA540 C580: CGA580 C590: CGA590 C326: CGA326 Other connections available	00: 1/4" NPT(F) 01: 1/4" NPT(M) 10: 1/8" GENLOK 11: 1/4" GENLOK 12: 3/8" GENLOK 14B: 1/4" Hose Barb Other connections available	D: Diaphragm Valve N: Needle Valve R: Relief Valve
	F: 500 psig	H: 0-150 psig I: 0-100 psig K: 0-50 psig M: 0-15 psig	K: Gauge W: No Gauge	C510: CGA510 C300: CGA300 Other connections available	Same as above	D: Diaphragm Valve N: Needle Valve R: Relief Valve

HP152T SERIES

High Purity Medium Flow Regulator

Specialty Gas Equipment

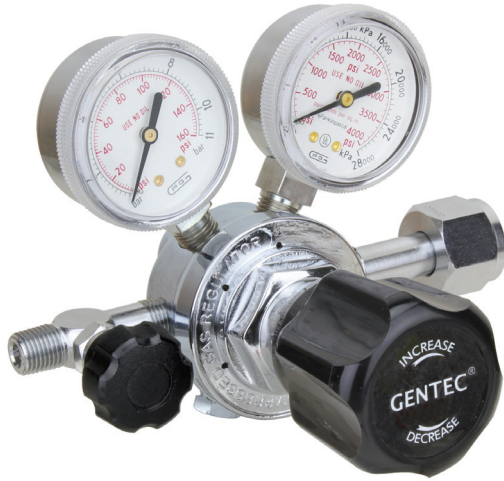

» HP152T-DIK-C540-01-NR

Materials

- **Body** Nickel-Plated Forged Brass
- **Bonnet** Nickel-Plated Forged Brass
- **Seat** PU
- **Diaphragm** 316L Stainless Steel
- **Adjusting Knob** ABS Plastic

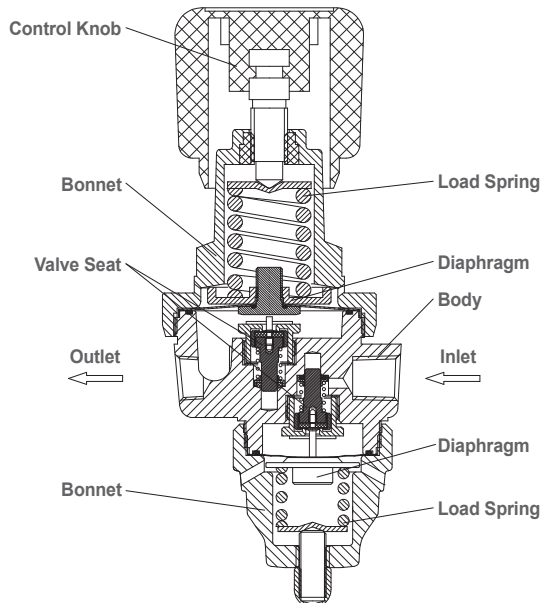

GENTEC® HP 152T Series is a Dual-Stage High Purity Brass Regulator designed for High Purity applications where a consistent outlet pressure and flow are desired.

Not recommended for corrosive gases.

Product Features

- 2" 316L Stainless Steel Diaphragm
- 2" Dual-Scale Pressure Gauges
- Optional outlet: Needle Valve or Diaphragm Valve
- Conforms to CGA E-4 standard for Gas Pressure Regulators

Applications

- Calibration of Pressures Gauges & Test Equipment
- Applications where constant delivery pressure required
- Supply of carrier gases for Gas Chromatography

Specifications

- **Maximum inlet pressure:** 3000 psig
- **Maximum outlet pressure:** 250 psig
- **Operating temperature range:** 0 to 140°F (-17 to 60°C)
- **Weight:** 3 lb 2 oz

Dimensions

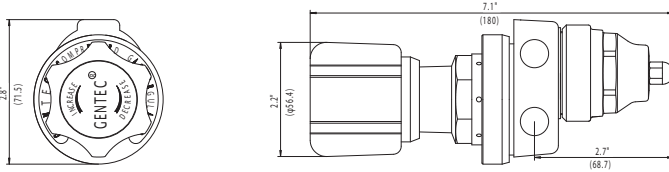

Flow Data

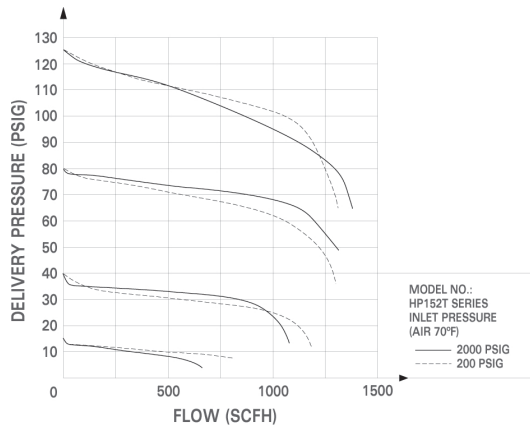

Ordering Information

EX: HP152T- Series	D Inlet Pressure Range	I Outlet Pressure Ranges	K - Gauge	C540 - Inlet Connections	01 - Outlet Connections	NR Options
• HP152T	D: 3000 psig	G: 0-250 psig H: 0-150 psig I: 0-100 psig K: 0-50 psig M: 0-15 psig	K: Gauge W: No Gauge	00: 1/4" NPT(F) C346: CGA346 C320: CGA320 C350: CGA350 C510: CGA510 C540: CGA540 C580: CGA580 C590: CGA590 C326: CGA326 Other connections available	00: 1/4" NPT(F) 01: 1/4" NPT(M) 10: 1/8" GENLOK 11: 1/4" GENLOK 12: 3/8" GENLOK 14B: 1/4" Hose Barb Other connections available	D: Diaphragm Valve N: Needle Valve R: Relief Valve

R21B SERIES

High Purity Low Flow Line Regulator

Specialty Gas Equipment



» R21BJT-FGK-11-11

Materials

- | | |
|-------------|------------------------------|
| • Body | Nickel-Plated Brass Barstock |
| • Seat | PTFE |
| • Diaphragm | 316L Stainless Steel |
| • Stem | 316L Stainless Steel |
| • Spring | 316L Stainless Steel |

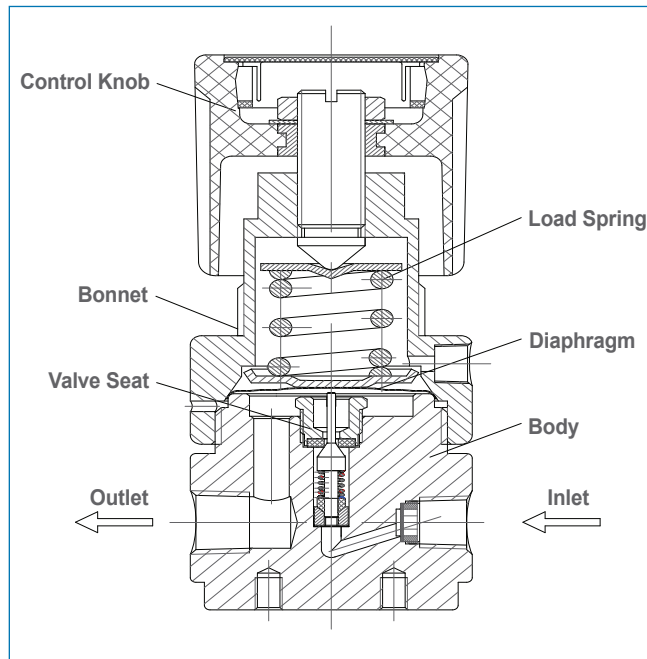

GENTEC® R21B Series Regulator is a Diaphragm-Sensed Single-Stage High Purity Line Regulator designed for applications where low flow is desired.

Product Features

- Single-Stage Configuration
- Metal-to-Metal Seal
- Body Port Size: 1/4" NPT(F)
- 2" Pressure Gauge

Applications

- Semiconductor Industry
- Research Laboratories
- Process Analyzer
- Gas Chromatography
- Petrochemical Industry
- Power Plants

Specifications

- Maximum inlet pressure: 500 psig
- Maximum outlet pressure: 250 psig
- Safety test pressure: 1.5 x Maximum inlet pressure
- Temperature range: -40°F~165°F (-40°C~ 74°C)
- Inboard leakage: 2×10^{-8} atm.cc/sec He
- Outboard leakage: 2×10^{-8} atm.cc/sec He inlet pressure: 1500 psig
- Maximum Cv: 0.14
- Weight: 2.2 lb

Dimensions

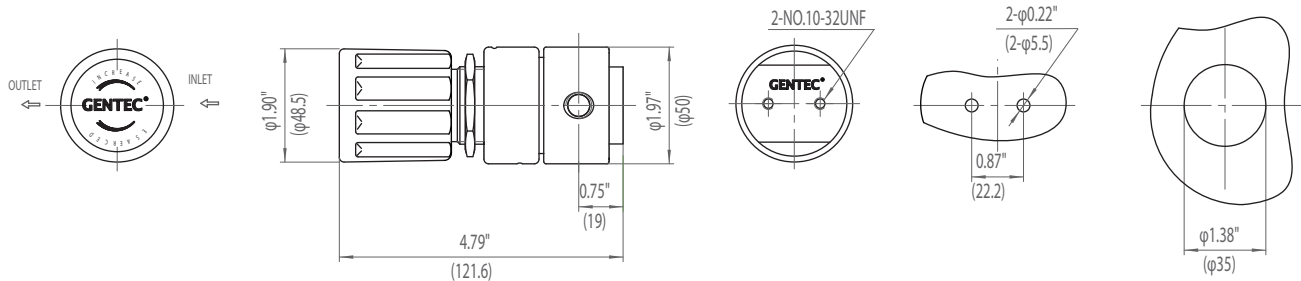

Rear Bracket Mount Front Panel Mount
Max. Thickness: 1/4" (7mm)

Flow Data

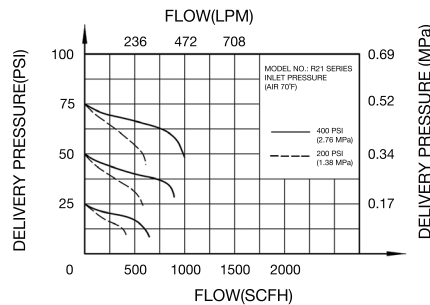
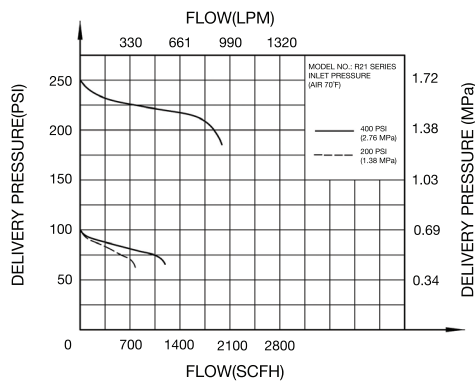

Body Port

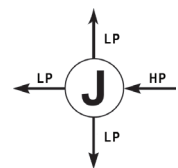

Ordering Information

EX:R21B	J	T -	F	G	K -	11 -	11	
Series	Body Ports	Seat	Inlet Pressure Range	Outlet Pressure Ranges	Gauge	Inlet Connections	Outlet Connections	Options
• R21B	J	T: PTFE	F: 500 psig	G: 0-250 psig I: 0-100 psig K: 0-50 psig L: 0-25 psig Q: 30" Hg Vac-30 psig S: 30" Hg Vac-100 psig T: 30" Hg Vac-200 psig	K: Gauge W: No Gauge	00: 1/4" NPT(F) 01: 1/4" NPT(M) 10: 1/8" GENLOK 11: 1/4" GENLOK Other connections available	00: 1/4" NPT(F) 01: 1/4" NPT(M) 10: 1/8" GENLOK 11: 1/4" GENLOK Other connections available	Blank: None D: Diaphragm Valve N: Needle Valve P: Panel Mount

R21B SERIES

High Purity Low Flow Regulators

Specialty Gas Equipment



» R21BMK-DIK-C590-11-D

Materials

- | | |
|------------------|------------------------------|
| • Body | Nickel-Plated Brass Barstock |
| • Bonnet | Nickel-Plated Brass Barstock |
| • Seat | PCTFE |
| • Diaphragm | 316L Stainless Steel |
| • Adjusting Knob | ABS Plastic |

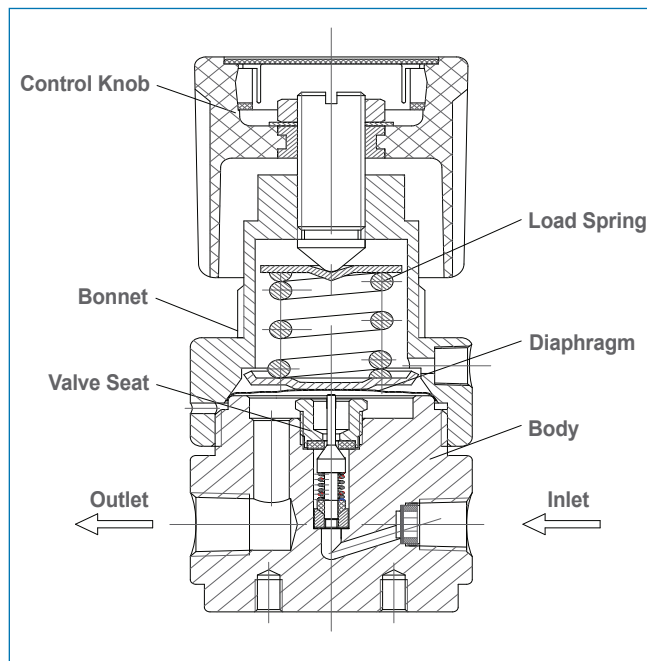

GENTEC® R21B Series Brass Regulator is a Diaphragm-Sensed Single-Stage High Purity regulator designed for use with analytical applications using non-corrosive gases.

Product Features

- Single-Stage Configuration
- Metal-to-Metal Seal
- Body Port Size: 1/4" NPT(F)
- 2" Pressure Gauge

Applications

- Semiconductor Industry
- Research Laboratories
- Process Analyzer
- Gas Chromatography
- Petrochemical Industry
- Power Plants

Specifications

- Maximum inlet pressure: 3000 psig
- Maximum outlet pressure: 500 psig
- Safety test pressure: 1.5 x Maximum inlet pressure
- Temperature range: -40°F~165°F (-40°C~ 74°C)
- Inboard leakage: 2×10^{-8} atm.cc/sec He
- Outboard leakage: 2×10^{-8} atm.cc/sec He inlet pressure: 1500 psig
- Maximum Cv: 0.14
- Weight: 2.2 lb

Dimensions

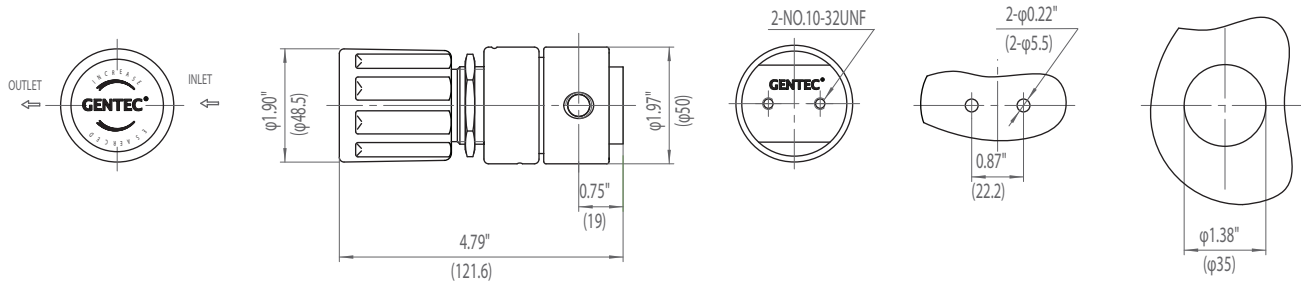

Rear Bracket Mount Front Panel Mount
Max. Thickness: 1/4" (7mm)

Flow Data

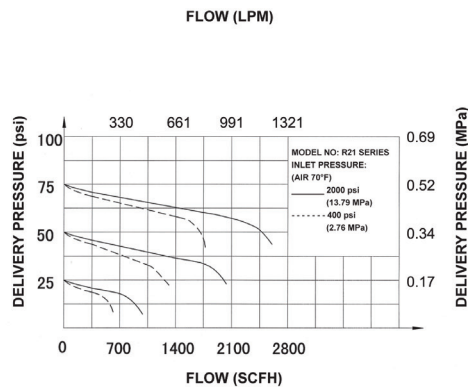
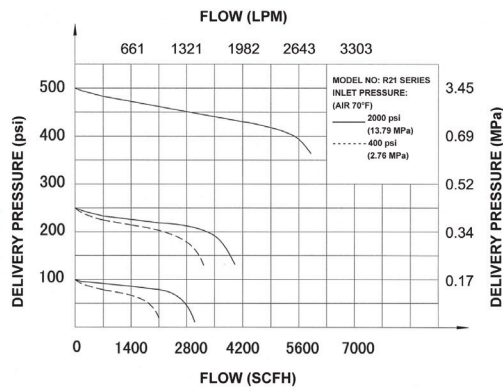

Body Ports

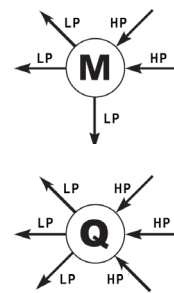

Ordering Information

EX:R21B	M	K -	D	I	K -	C590 -	11 -	D
Series	Body Ports	Seat	Inlet Pressure Range	Outlet Pressure Ranges	Gauge	Inlet Connections	Outlet Connections	Options
• R21B	M Q	K: PCTFE	D: 3000 psig	F: 0-500 psig G: 0-250 psig I: 0-100 psig K: 0-50 psig L: 0-25 psig Q: 30" Hg Vac-30 psig S: 30" Hg Vac-100 psig T: 30" Hg Vac-200 psig	K: Gauge W: No Gauge	00: 1/4" NPT(F) C346: CGA346 C320: CGA320 C350: CGA350 C510: CGA510 C540: CGA540 C580: CGA580 C590: CGA590 C326: CGA326 Other connections available	00: 1/4" NPT(F) 01: 1/4" NPT(M) 10: 1/8" GENLOK 11: 1/4" GENLOK Other connections available	Blank: None D: Diaphragm Valve N: Needle Valve R: Relief Valve

R22B SERIES

High Purity Medium Flow Line Regulator

Specialty Gas Equipment



» R22BJK-FKK-13-13

Materials

- **Body** Nickel-Plated Brass Barstock
- **Bonnet** Nickel-Plated Brass Barstock
- **Seat** PCTFE
- **Diaphragm** 316L Stainless Steel
- **Adjusting Knob** ABS Plastic

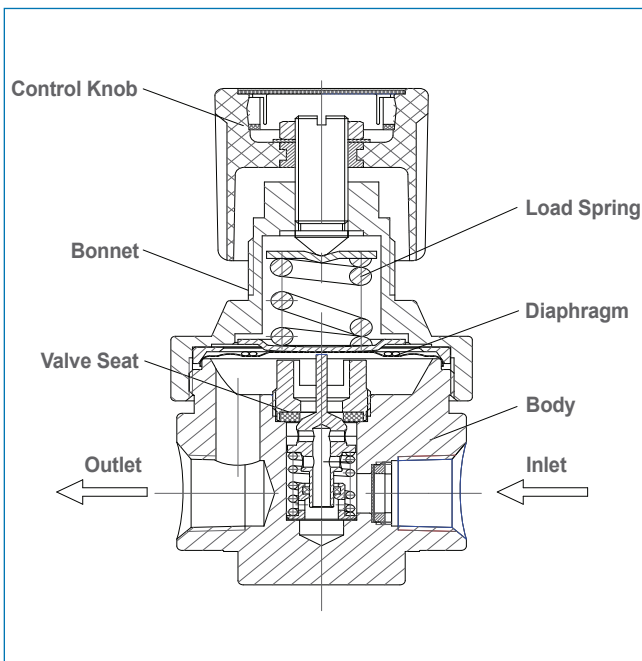

GENTEC® R22B Brass Line Regulator is a Diaphragm-Sensed Single-Stage High Purity regulator designed for applications where medium flow is desired.

Product Features

- Single-Stage Configuration
- Metal-to-Metal Seal
- Body Port Size: 1/2" NPT(F)
- 2" Pressure Gauge

Applications

- Semiconductor Industry
- Gas Manifold Systems
- Research Laboratories
- Petrochemical Industry
- Power Plants

Specifications

- **Maximum inlet pressure:** 500 psig
- **Maximum outlet pressure:** 250 psig
- **Safety test pressure:** 1.5 x Maximum inlet pressure
- **Temperature range:** -40°F~165°F (-40°C~ 74°C)
- **Inboard leakage:** 2×10^{-8} atm.cc/sec He
- **Outboard leakage:** 2×10^{-8} atm.cc/sec He inlet pressure: 1500 psig
- **Maximum Cv:** 1.1
- **Weight:** 3.74 lb

Dimensions

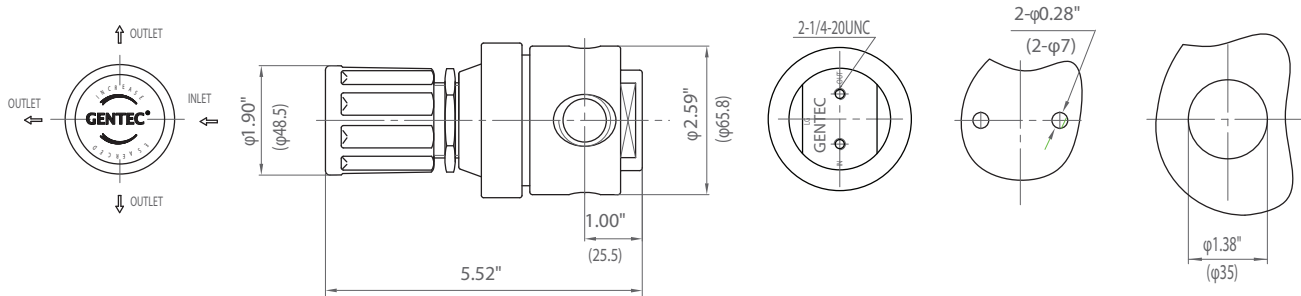

Rear Bracket Mount Front Panel Mount
Max. Thickness: 1/4" (7mm)

Flow Data

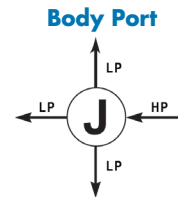
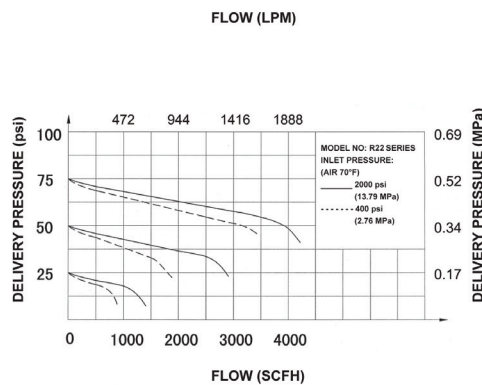
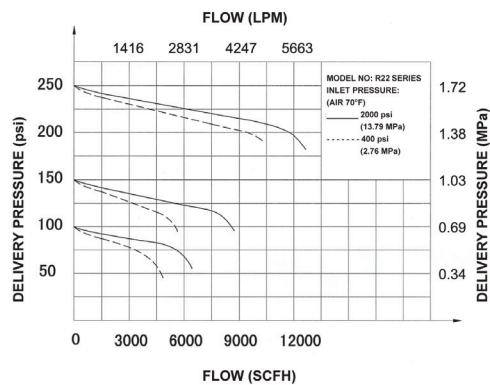

Ordering Information

EX:R22B	J	K -	F	K	K -	13 -	13	Options
	Body Ports	Seat	Inlet Pressure Range	Outlet Pressure Ranges	Gauge	Inlet Connections	Outlet Connections	
• R22B	J	K: PCTFE	F: 500 psig	G: 0-250 psig I: 0-100 psig K: 0-50 psig L: 0-25 psig Q: 30" Hg Vac-30 psig S: 30" Hg Vac-100 psig T: 30" Hg Vac-200 psig	K: Gauge W: No Gauge	04: 1/2" NPT(F) 05: 1/2" NPT(M) 13: 1/2" GENLOK Other connections available	04: 1/2" NPT(F) 05: 1/2" NPT(M) 13: 1/2" GENLOK Other connections available	Blank: None D: Diaphragm Valve N: Needle Valve P: Panel Mount

R31B SERIES

High Purity Low Flow Regulator

Specialty Gas Equipment



GENTEC® R31B Series Brass Regulator is a Diaphragm-Sensed Dual-Stage High Purity regulator designed for analytical applications where a consistent outlet pressure and flow are desired.

Product Features

- Dual-Stage Configuration
- Metal-to-Metal Seal
- Body Port Size: 1/4" NPT(F)
- 2" Pressure Gauge

» R31BMK-DQK-C350-11-D

Materials

- | | |
|------------------|------------------------------|
| • Body | Nickel-Plated Brass Barstock |
| • Bonnet | Nickel-Plated Brass Barstock |
| • Seat | PCTFE |
| • Diaphragm | 316L |
| • Adjusting Knob | ABS Plastic |

Applications

- Cylinders
- Research Laboratories
- Gas Chromatography
- Process Analyzers
- Petrochemical Industry
- Power Plant

Specifications

- Maximum inlet pressure: 3000 psig
- Maximum outlet pressure: 250 psig
- Safety test pressure: 1.5 x Maximum inlet pressure
- Temperature range: -40°F~165°F (-40°C~ 74°C)
- Inboard leakage: 2×10^{-8} atm.cc/sec He
- Outboard leakage: 2×10^{-8} atm.cc/sec He inlet pressure: 1500 psig
- Maximum Cv: 0.06
- Weight: 4.03 lb

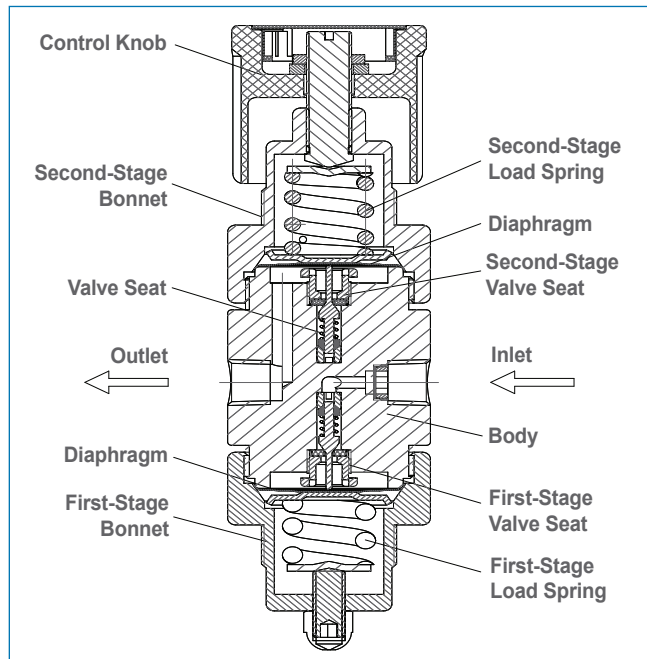

Dimensions

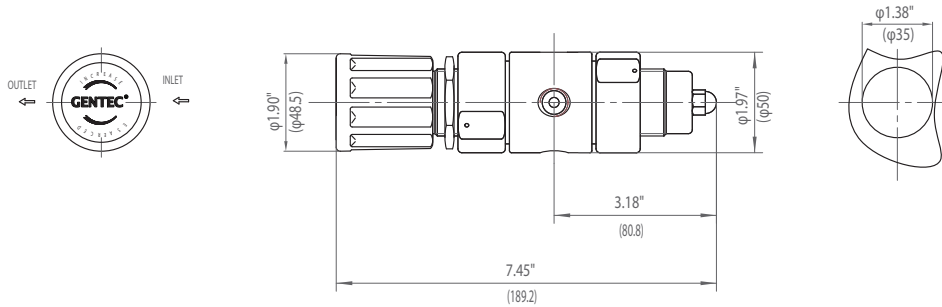

Front Panel Mount
Max. Thickness: 1/4" (7mm)

Flow Data

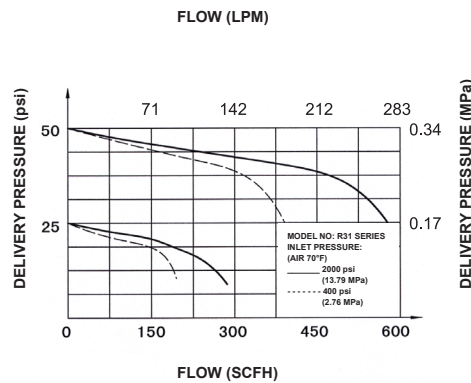
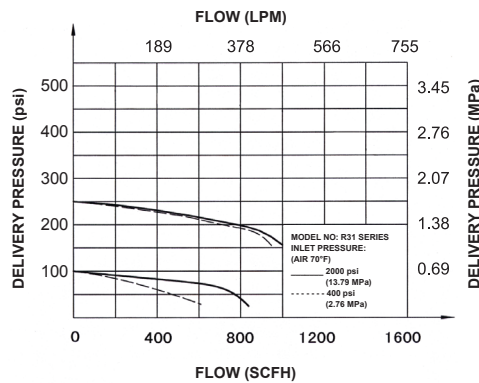

Body Ports

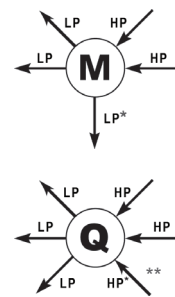

** For R31 Series, this high pressure "Q" port configuration is plugged. This port can be used for purging purpose only.

* For the "M" port configuration of R31 Series, this port is plugged and cannot be used for relief valve installation.

Ordering Information

EX:R31B	M	K -	D	Q	K -	C350 -	11 -	D
Series	Body Ports	Seat	Inlet Pressure Range	Outlet Pressure Ranges	Gauge	Inlet Connections	Outlet Connections	Options
• R31B	M Q	K: PCTFE	D: 3000 psig	G: 0-250 psig I: 0-100 psig K: 0-50 psig L: 0-25 psig Q: 30" Hg Vac-30 psig S: 30" Hg Vac-100 psig T: 30" Hg Vac-200 psig	K: Gauge W: No Gauge	00: 1/4" NPT(F) C346: CGA346 C320: CGA320 C350: CGA350 C510: CGA510 C540: CGA540 C580: CGA580 C590: CGA590 C326: CGA326 Other connections available	00: 1/4" NPT(F) 01: 1/4" NPT(M) 10: 1/8" GENLOK 11: 1/4" GENLOK 12: 3/8" GENLOK 14B: 1/4" Hose Barb Other connections available	Blank: None D: Diaphragm Valve N: Needle Valve P: Panel Mount R: Relief Valve

R21SL SERIES

High Purity Low Flow Line Regulator

Specialty Gas Equipment

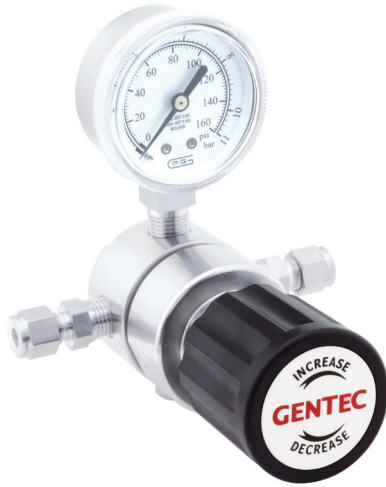

GENTEC® R21SL Series Stainless Steel Line Regulator is a Diaphragm-Sensed Single-Stage High Purity Line Regulator.

» R21SLJT-FIK-11-11

Materials

- | | |
|-------------|----------------------|
| • Body | 316L Stainless Steel |
| • Seat | PTFE |
| • Diaphragm | 316L Stainless Steel |
| • Stem | 316L Stainless Steel |
| • Spring | 316 Stainless Steel |

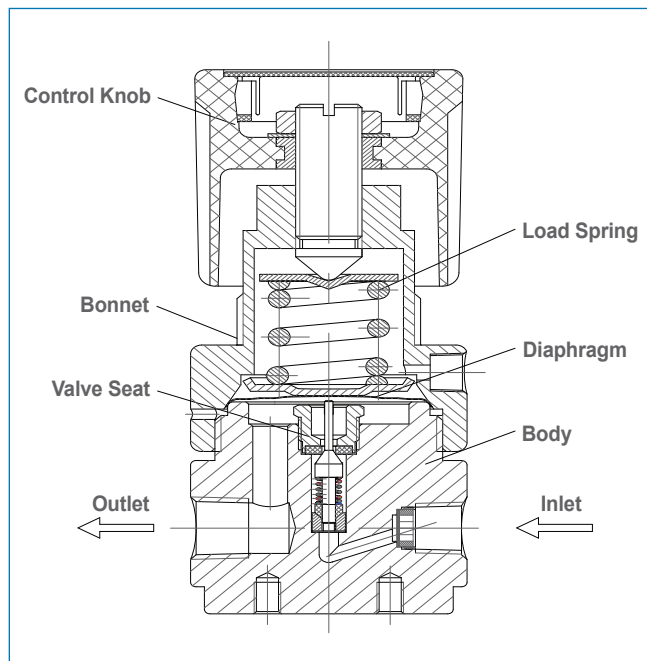

Product Features

- Single-Stage Configuration
- Metal-to-Metal Seal
- Body Port Size: 1/4" NPT(F)
- 2" Pressure Gauge

Applications

- Semiconductor Industry
- Research Laboratories
- Process Analyzer
- Gas Chromatography
- Petrochemical Industry
- Power Plants

Specifications

- Maximum inlet pressure: 500 psig
- Maximum outlet pressure: 250 psig
- Safety test pressure: 1.5 x Maximum inlet pressure
- Temperature range: -40°F~165°F (-40°C~ 74°C)
- Inboard leakage: 2×10^{-8} atm.cc/sec He
- Outboard leakage: 2×10^{-8} atm.cc/sec He inlet pressure: 1500 psig
- Maximum Cv: 0.14
- Weight: 2.2 lb

Dimensions

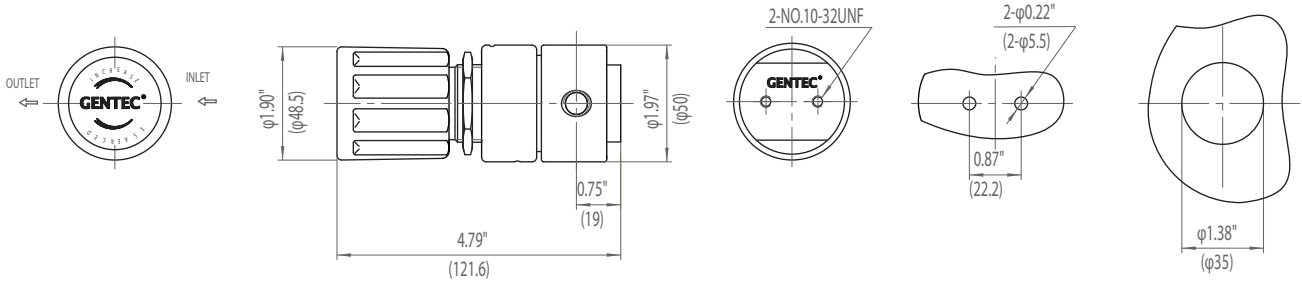

Rear Bracket Mount Front Panel Mount
Max. Thickness: 1/4" (7mm)

Flow Data

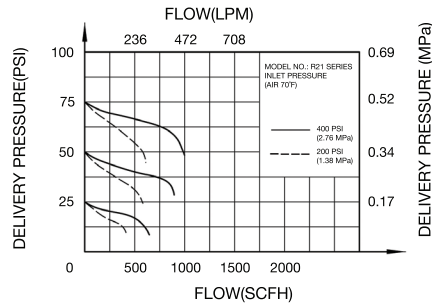
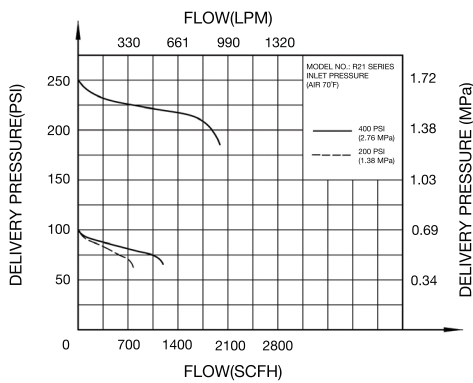

Body Port

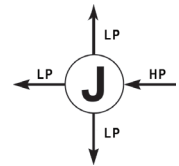

Ordering Information

EX:R21SL	J	T -	F	I	K -	11 -	11	
Series	Body Ports	Seat	Inlet Pressure Range	Outlet Pressure Ranges	Gauge	Inlet Connections	Outlet Connections	Options
• R21SL	J	T: PTFE	F: 500 psig	G: 0-250 psig I: 0-100 psig K: 0-50 psig L: 0-25 psig Q: 30" Hg Vac-30 psig S: 30" Hg Vac-100 psig T: 30" Hg Vac-200 psig	K: Gauge W: No Gauge	00: 1/4" NPT(F) 01: 1/4" NPT(M) 10: 1/8" GENLOK 11: 1/4" GENLOK Other connections available	00: 1/4" NPT(F) 01: 1/4" NPT(M) 10: 1/8" GENLOK 11: 1/4" GENLOK Other connections available	Blank: None D: Diaphragm Valve N: Needle Valve P: Panel Mount

R21SL SERIES

High Purity Low Flow Regulator

Specialty Gas Equipment



GENTEC® R21SL Series Stainless Steel Regulator is a Diaphragm-Sensed Single-Stage High Purity Regulator.

Product Features

- Single-Stage Configuration
- Metal-to-Metal Seal
- Body Port Size: 1/4" NPT(F)
- 2" Pressure Gauge

» R21SLMK-DIK-C580-11-D

Materials

- | | |
|------------------|----------------------|
| • Body | 316L Stainless Steel |
| • Bonnet | 316 Stainless Steel |
| • Seat | PCTFE |
| • Diaphragm | 316L Stainless Steel |
| • Adjusting Knob | ABS Plastic |

Applications

- Semiconductor Industry
- Research Laboratories
- Process Analyzer
- Gas Chromatography
- Petrochemical Industry
- Power Plants

Specifications

- Maximum inlet pressure: 3000 psig
- Maximum outlet pressure: 250 psig
- Safety test pressure: 1.5 x Maximum inlet pressure
- Temperature range: -40°F~165°F (-40°C~ 74°C)
- Inboard leakage: 2×10^{-8} atm.cc/sec He
- Outboard leakage: 2×10^{-8} atm.cc/sec He inlet pressure: 1500 psig
- Maximum Cv: 0.14
- Weight: 2.2 lb

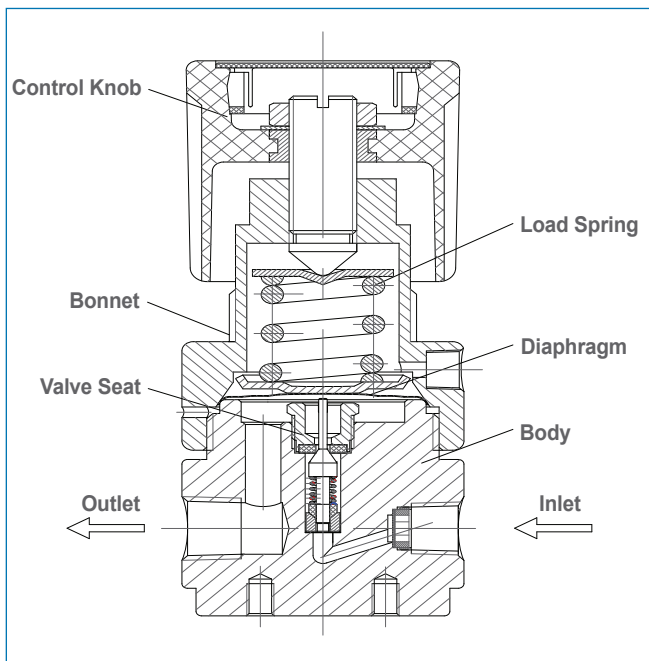

Dimensions

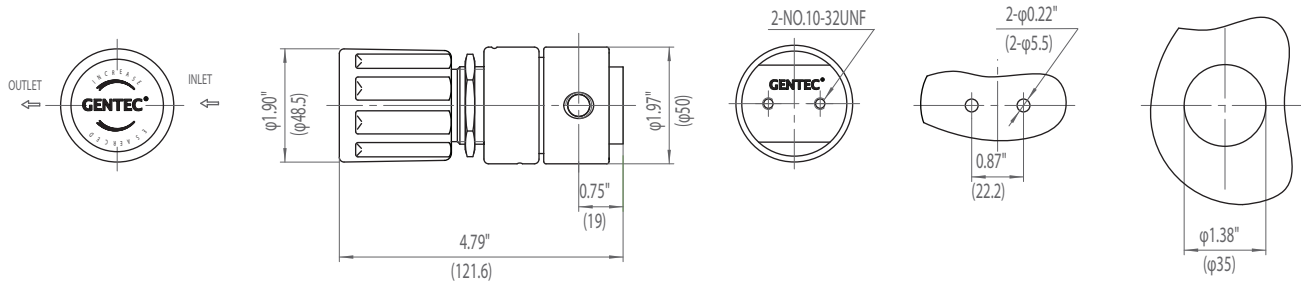

Rear Bracket Mount Front Panel Mount
Max. Thickness: 1/4" (7mm)

Flow Data

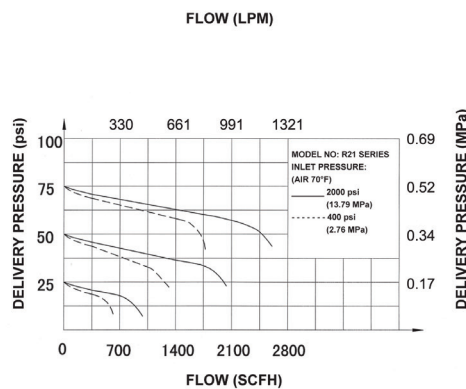
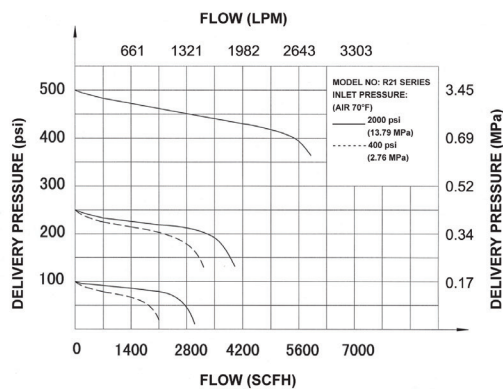

Body Ports

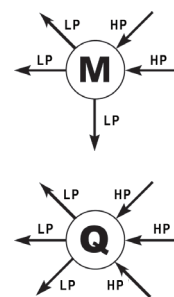

Ordering Information

EX:R21SL	M	K -	D	I	K -	C580 -	11 -	D
Series	Body Ports	Seat	Inlet Pressure Range	Outlet Pressure Ranges	Gauge	Inlet Connections	Outlet Connections	Options
• R21SL	M Q	K: PCTFE	D: 3000 psig	G: 0-250 psig I: 0-100 psig K: 0-50 psig L: 0-25 psig Q: 30" Hg Vac-30 psig S: 30" Hg Vac-100 psig T: 30" Hg Vac-200 psig	K: Gauge W: No Gauge	00: 1/4" NPT(F) C346: CGA346 C320: CGA320 C350: CGA350 C510: CGA510 C540: CGA540 C580: CGA580 C590: CGA590 C326: CGA326 Other connections available	00: 1/4" NPT(F) 01: 1/4" NPT(M) 10: 1/8" GENLOK 11: 1/4" GENLOK Other connections available	D: Diaphragm Valve N: Needle Valve P: Panel Mount R: Relief Valve

R22SL SERIES

High Purity Medium Flow Line Regulator

Specialty Gas Equipment



» R22SLJK-FGK-13-13

Materials

- | | |
|------------------|------------------------------|
| • Body | 316 Stainless Steel |
| • Bonnet | Nickel-Plated Brass Barstock |
| • Seat | PCTFE |
| • Diaphragm | 316L Stainless Steel |
| • Adjusting Knob | ABS Plastic |

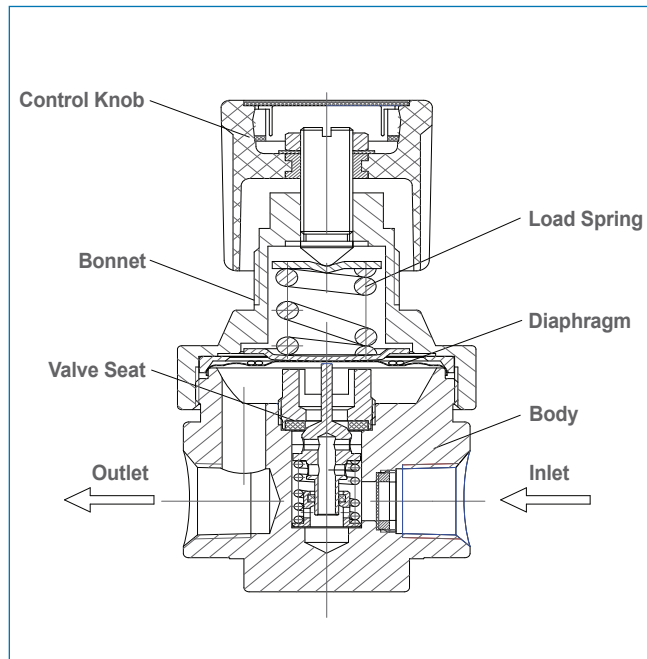

GENTEC® R22SL Stainless Steel Line Regulator is a Diaphragm-Sensed Single-Stage High Purity Regulator designed for applications where medium flow is desired.

Product Features

- Single-Stage Configuration
- Metal-to-Metal Seal
- Body Port Size: 1/2" NPT(F)
- 2" Pressure Gauge

Applications

- Semiconductor Industry
- Gas Manifold Systems
- Research Laboratories
- Petrochemical Industry
- Power Plants

Specifications

- Maximum inlet pressure: 500 psig
- Maximum outlet pressure: 250 psig
- Safety test pressure: 1.5 x Maximum inlet pressure
- Temperature range: -40°F~165°F (-40°C~ 74°C)
- Inboard leakage: 2×10^{-8} atm.cc/sec He
- Outboard leakage: 2×10^{-8} atm.cc/sec He inlet pressure: 1500 psig
- Maximum Cv: 1.1
- Weight: 3.74 lb

Dimensions

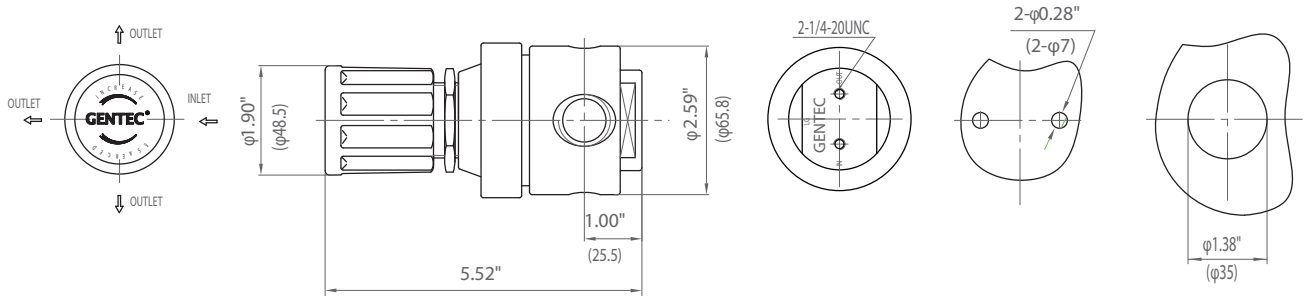

Rear Bracket Mount Front Panel Mount
Max. Thickness: 1/4" (7mm)

Flow Data

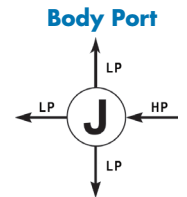
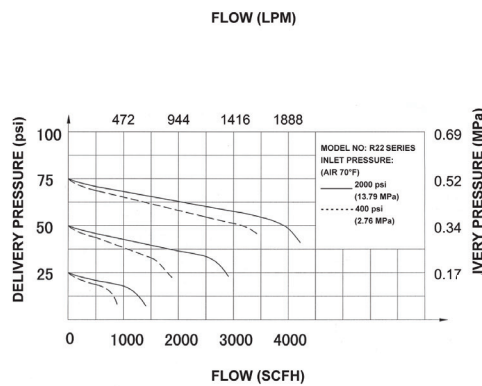
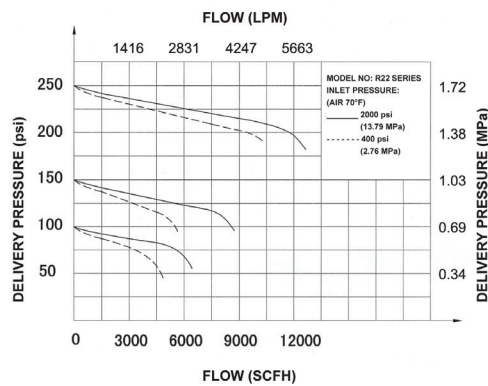

Ordering Information

EX:R22SL	J	K -	F	G	K -	13 -	13	
Series	Body Ports	Seat	Inlet Pressure Range	Outlet Pressure Ranges	Gauge	Inlet Connections	Outlet Connections	Options
• R22SL	J	K: PCTFE	F: 500 psig	G: 0-250 psig I: 0-100 psig K: 0-50 psig L: 0-25 psig Q: 30" Hg Vac-30 psig S: 30" Hg Vac-100 psig T: 30" Hg Vac-200 psig	K: Gauge W: No Gauge	04: 1/2" NPT(F) 05: 1/2" NPT(M) 13: 1/2" GENLOK Other connections available	04: 1/2" NPT(F) 05: 1/2" NPT(M) 13: 1/2" GENLOK Other connections available	Blank: None D: Diaphragm Valve N: Needle Valve P: Panel Mount

R31SL SERIES

High Purity Low Flow Regulator

Specialty Gas Equipment



GENTEC® R31SL Series Stainless Steel Regulator is a Diaphragm-Sensed Dual-Stage High Purity Regulator designed for applications where a consistent outlet pressure and flow are desired.

Product Features

- Dual-Stage Configuration
- Metal-to-Metal Seal
- Body Port Size: 1/4" NPT(F)
- 2" Pressure Gauge

» R31SLMK-DIK-C350-11-D

Materials

- | | |
|------------------|----------------------|
| • Body | 316 Stainless Steel |
| • Bonnet | 316L Stainless Steel |
| • Seat | PCTFE |
| • Diaphragm | 316L Stainless Steel |
| • Adjusting Knob | ABS Plastic |

Applications

- Research Laboratories
- Gas Chromatography
- Process Analyzers
- Petrochemical Industry
- Power Plant

Specifications

- Maximum inlet pressure: 3000 psig
- Maximum outlet pressure: 250 psig
- Safety test pressure: 1.5 x Maximum inlet pressure
- Temperature range: -40°F~165°F (-40°C~ 74°C)
- Inboard leakage: 2×10^{-8} atm.cc/sec He
- Outboard leakage: 2×10^{-8} atm.cc/sec He inlet pressure: 1500 psig
- Maximum Cv: 0.06
- Weight: 4.03 lb

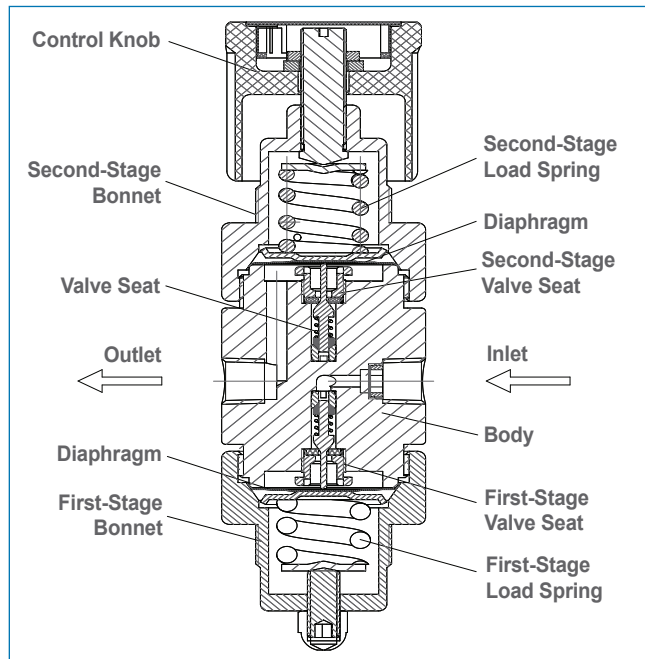

Dimensions

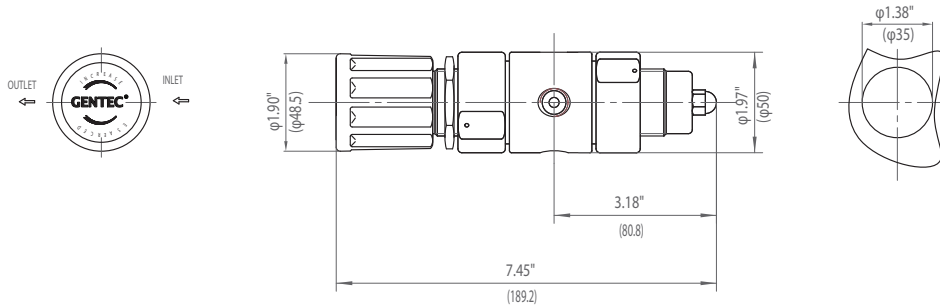

Front Panel Mount
Max. Thickness: 1/4" (7mm)

Flow Data

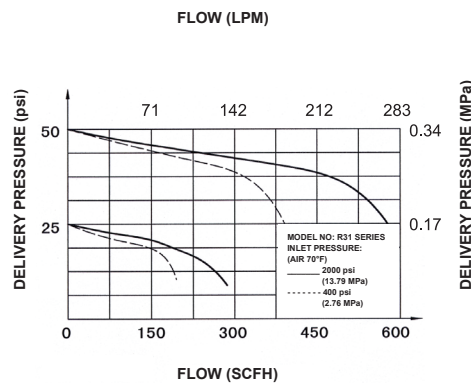
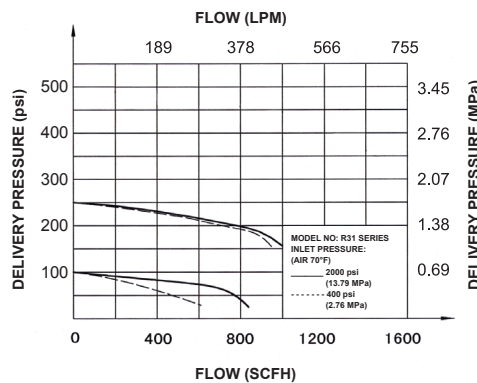

Body Ports

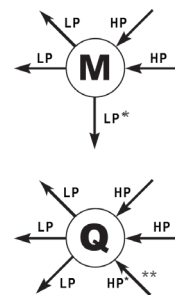

** For R31 Series, this high pressure "Q" port configuration is plugged. This port can be used for purging purpose only.

* For the "M" port configuration of R31 Series, this port is plugged and cannot be used for relief valve installation.

Ordering Information

EX:R31SL	M	K -	D	I	K -	C350 -	11 -	D
Series	Body Ports	Seat	Inlet Pressure Range	Outlet Pressure Ranges	Gauge	Inlet Connections	Outlet Connections	Options
• R31SL	M Q	K: PCTFE	D: 3000 psig	G: 0-250 psig I: 0-100 psig K: 0-50 psig L: 0-25 psig Q: 30" Hg Vac-30 psig S: 30" Hg Vac-100 psig T: 30" Hg Vac-200 psig	K: Gauge W: No Gauge	00: 1/4" NPT(F) C330: CGA330 C350: CGA350 C580: CGA580 C660: CGA660 C590: CGA590 Other connections available	00: 1/4" NPT(F) 01: 1/4" NPT(M) 10: 1/8" GENLOK 11: 1/4" GENLOK 14B: 1/4" Hose Barb Other connections available	Blank: None D: Diaphragm Valve N: Needle Valve P: Panel Mount R: Relief Valve

R44SL SERIES

High Purity / High Pressure Low Flow Regulator

Specialty Gas Equipment



» R44SLMK-BDK-C590-11-D

Materials

- Body 316L Stainless Steel
- Bonnet 316L Stainless Steel
- Seat PCTFE
- Diaphragm 316L Stainless Steel
- Adjusting Knob ABS Plastic

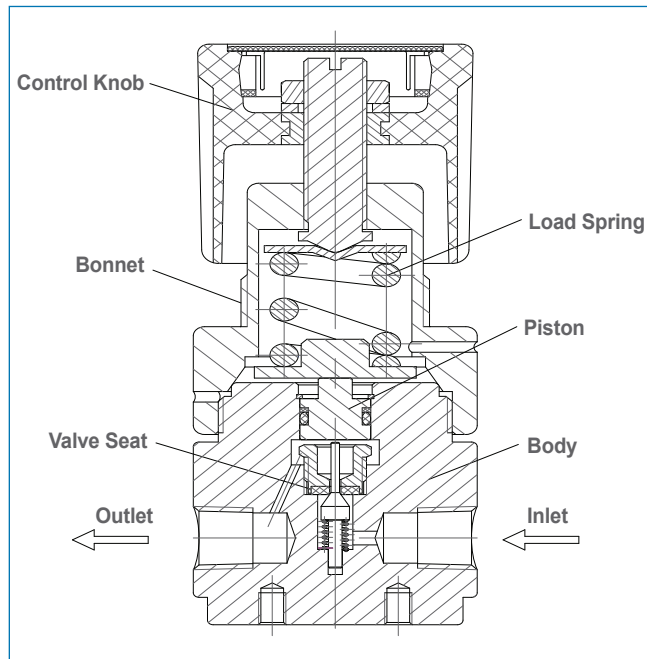

GENTEC® R44SL Series High Pressure Stainless Steel Regulator is a Piston-Sensed Single-Stage High Purity Regulator designed for applications where high pressure and low flow control are desired.

Product Features

- Piston-Sensed Configuration
- Metal-to-Metal Seal
- Body Port Size: 1/4" NPT(F)
- 2" Pressure Gauge

Applications

- Gas Chromatography
- Research Laboratories
- Petrochemical Industry
- Power Plant

Specifications

- Maximum inlet pressure: 6000 psig
- Maximum outlet pressure: 3000 psig
- Safety test pressure: 1.5 x Maximum inlet pressure
- Temperature range: -40°F~165°F (-40°C~ 74°C)
- Inboard leakage: 2×10^{-8} atm.cc/sec He
- Outboard leakage: 2×10^{-8} atm.cc/sec He inlet pressure: 1500 psig
- Maximum Cv: 0.06
- Weight: 2.2 lb

Dimensions

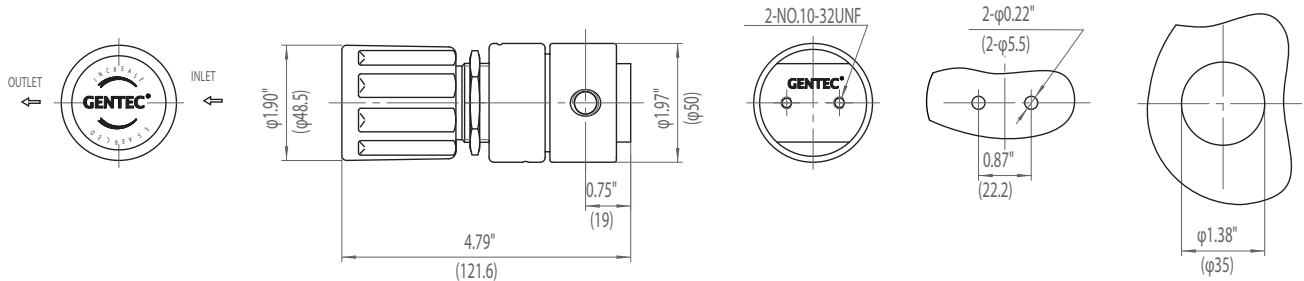

Rear Bracket Mount Front Panel Mount
Max. Thickness: 1/4" (7mm)

Flow Data

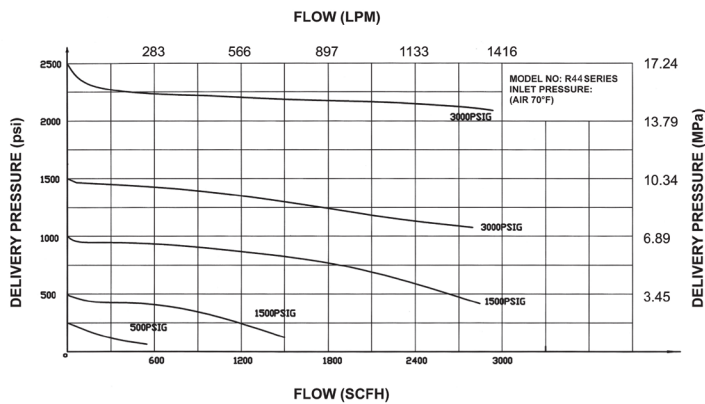

Body Port

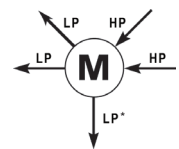

Ordering Information

EX:R44SL	M	K -	B	D	K -	C590 -	11 -	D
Series	Body Ports	Seat	Inlet Pressure Ranges	Outlet Pressure Ranges	Gauge	Inlet Connections	Outlet Connections	Options
• R44SL	M	K: PCTFE	B: 6000psig C: 4500psig D: 3000 psig	D: 0-3000psig E: 0-1500psig F: 0-500psig G: 0-250 psig	K: Gauge W: No Gauge	00: 1/4" NPT(F) C350: CGA350 C540: CGA540 C580: CGA580 C590: CGA590 C677: CGA677 C680: CGA680 C695: CGA695 Other connections available	00: 1/4" NPT(F) 01: 1/4" NPT(M) 10: 1/8" GENLOK 11: 1/4" GENLOK 14B: 1/4" Hose Barb Other connections available	Blank: None D: Diaphragm Valve N: Needle Valve P: Panel Mount Some valves not available depending on delivery pressures

R45SL SERIES

Ultra High Pressure Low Flow Regulator

Specialty Gas Equipment



» R45SLGV-BEK-00-00

Materials

- Body 316L Stainless Steel
- Seat VESPEL®
- Piston 316L Stainless Steel
- Adjusting Knob ABS Plastic
- O-ring Viton

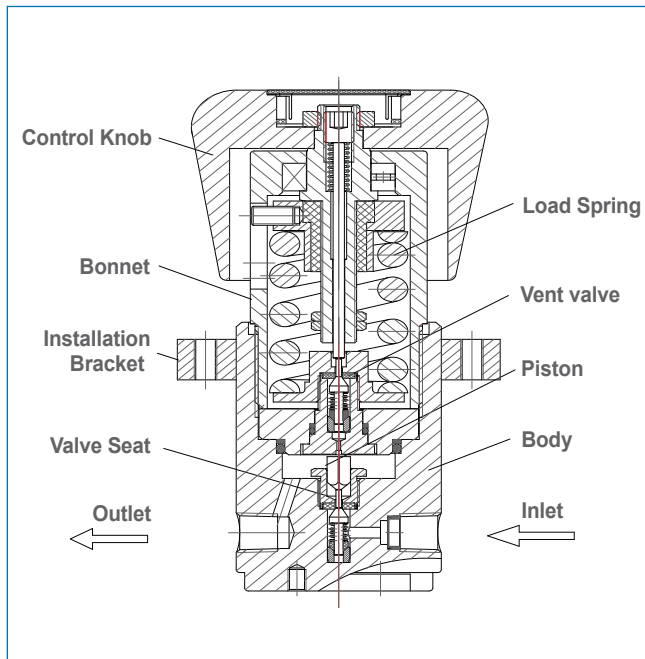

GENTEC® R45SL Series Ultra High Pressure Single-Stage Regulator is a Piston-Sensed Regulator applicable for highest pressure applications.

Product Features

- Single-Stage Configuration
- Metal-to-Metal Seal
- Body Port Size: 1/4" NPT(F)
- 2" Pressure Gauge

Applications

- Semiconductor Industry
- Research Laboratories
- Process Analyzer
- Gas Chromatography
- Petrochemical Industry
- Power Plants

Specifications

- Maximum inlet pressure: 10000 psig
- Maximum outlet pressure: 6000 psig
- Safety test pressure: 1.5 x Maximum inlet pressure
- Temperature range: -40°F~165°F (-40°C~ 74°C)
- Inboard leakage: 2×10^{-8} atm.cc/sec He
- Outboard leakage: 2×10^{-8} atm.cc/sec He inlet pressure: 1500 psig
- Maximum Cv: 0.06
- Weight: 4.85 lb

Dimensions

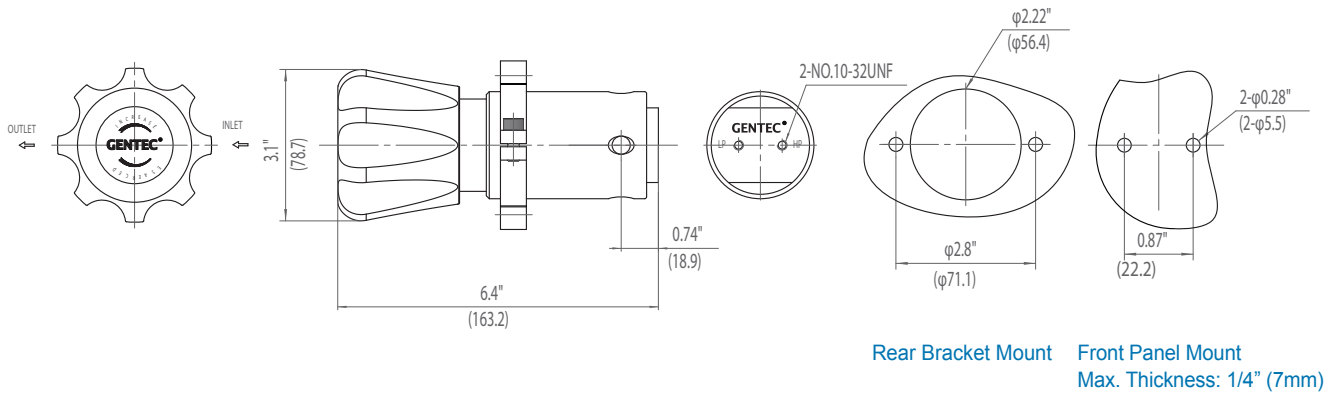

Flow Data

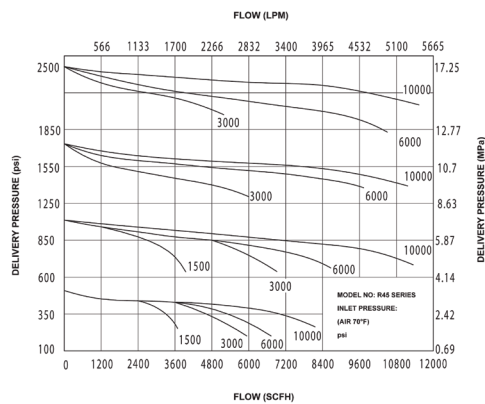
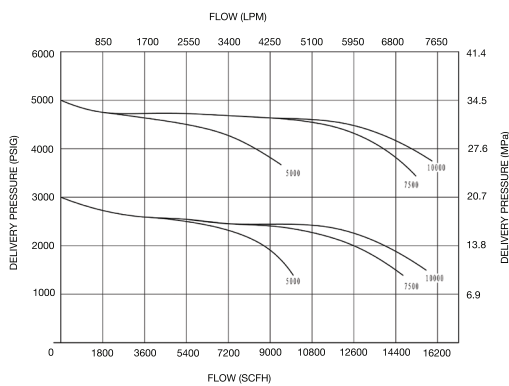

Body Port

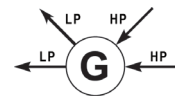

Ordering Information

EX:R45SL	G	V -	B	E	K -	00 -	00 -	
Series	Body Ports	Seat	Inlet Pressure Ranges	Outlet Pressure Ranges	Gauge	Inlet Connections	Outlet Connections	Options
• R45SL	G	V: Vespel®	A: 10000 psig B: 6000 psig	B: 0-6000psig C: 0-4500psig D: 0-3000psig E: 0-1500psig	K: Gauge W: No Gauge	00: 1/4" NPT(F) C347: CGA347 C677: CGA677 C680: CGA680	00: 1/4" NPT(F) 01: 1/4" NPT(M) 10: 1/8" GENLOK 11: 1/4" GENLOK 14B: 1/4" Hose Barb Other connections available	Blank: None D: Diaphragm Valve N: Needle Valve P: Panel Mount Some valves not available depending on delivery pressures

R51SL SERIES

Corrosion Resistant Low Flow Regulator

Specialty Gas Equipment



» R51SLGK-DIK-90-90

Materials

- **Body** 316L (EP) - Stainless Steel
- **Bonnet** 316L (EP) - Stainless Steel
- **Seat** PCTFE
- **Valve Stem:** C22 Hastelloy®
- **Diaphragm** C22 Hastelloy®

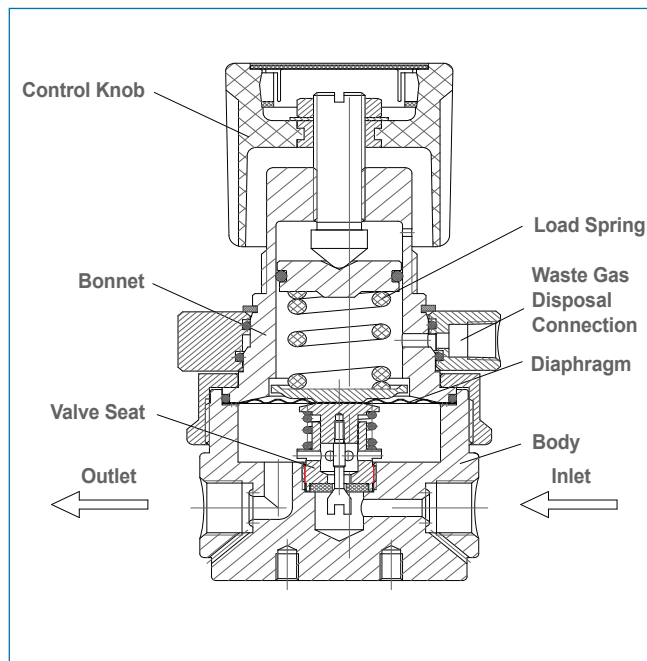

GENTEC® R51SL Series Corrosion-Resistant Single-Stage Regulator is Diaphragm-Sensed and especially designed for applications where corrosive and toxic gases are used.

Product Features

- Single-Stage Configuration
- Metal-to-Metal diaphragm to body seal & dual layer sealing ring
- Integrated waste gas disposal connection for additional safety
- Body Port Size: 1/4" FSR(F)

Applications

- Semiconductor Industry
- Solar Energy Industry
- Vacuum Plating Equipment
- Spec Gas Equipment

Specifications

- **Maximum inlet pressure:** 3000 psig
- **Maximum outlet pressure:** 500 psig
- **Safety test pressure:** 1.5 x Maximum inlet pressure
- **Temperature range:** -40°F~165°F (-40°C~ 74°C)
- **Inboard leakage:** 2×10^{-8} atm.cc/sec He
- **Outboard leakage:** 2×10^{-8} atm.cc/sec He inlet pressure: 1500 psig
- **Maximum Cv:** 0.06
- **Weight:** 3.42 lb

Dimensions

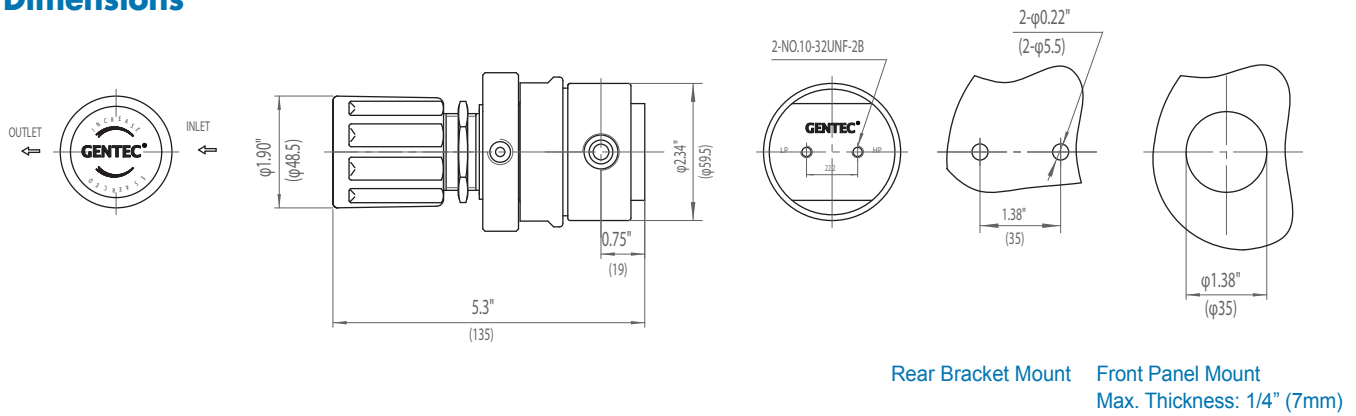

Flow Data

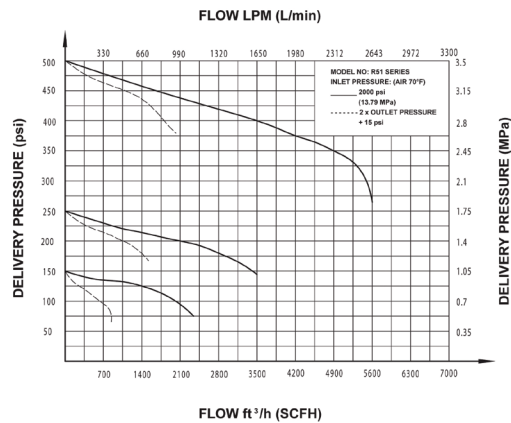

Body Port

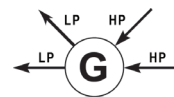

Ordering Information

EX:R51SL	G	K -	D	I	K -	90 -	90
Series	Body Ports	Seat	Inlet Pressure Range	Outlet Pressure Ranges	Gauge	Inlet Connections	Outlet Connections
• R51SL	G	K: PCTFE	D: 3000 psig	F: 0-500 psig G: 0-250 psig H: 0-150 psig I: 0-100 psig K: 0-50 psig L: 0-25 psig	K: Gauge W: No Gauge	90: Internal 1/4" FSR(F)	90: Internal 1/4" FSR(F)

R77SL SERIES

Back Pressure Low Flow Regulator

Specialty Gas Equipment



GENTEC® R77SL Series Back Pressure Regulator is a Diaphragm-Sensed Single-Stage High Purity Regulator designed for applications where a constant back pressure is desired.

Product Features

- Single-Stage Configuration
- Body Port Size: 1/4" NPT(F)
- 2" Pressure Gauge

» R77SLAK-GW-00-00

Materials

- | | |
|------------------|----------------------|
| • Body | 316L Stainless Steel |
| • Bonnet | 316L Stainless Steel |
| • Seat | PCTFE, PTFE |
| • Diaphragm | 316L Stainless Steel |
| • Adjusting Knob | ABS Plastic |

Applications

- Process Control
- Petrochemical Industry
- Gas Chromatography
- Research Laboratories

Specifications

- Maximum inlet pressure: 250 psig
- Safety test pressure: 1.5 x Maximum inlet pressure
- Temperature range: -40°F~165°F (-40°C~ 74°C)
- Inboard leakage: 2×10^{-9} atm.cc/sec He
- Outboard leakage: 2×10^{-8} atm.cc/sec He inlet pressure: 1500 psig
- Maximum Cv: 0.08
- Weight: 2.2 lb

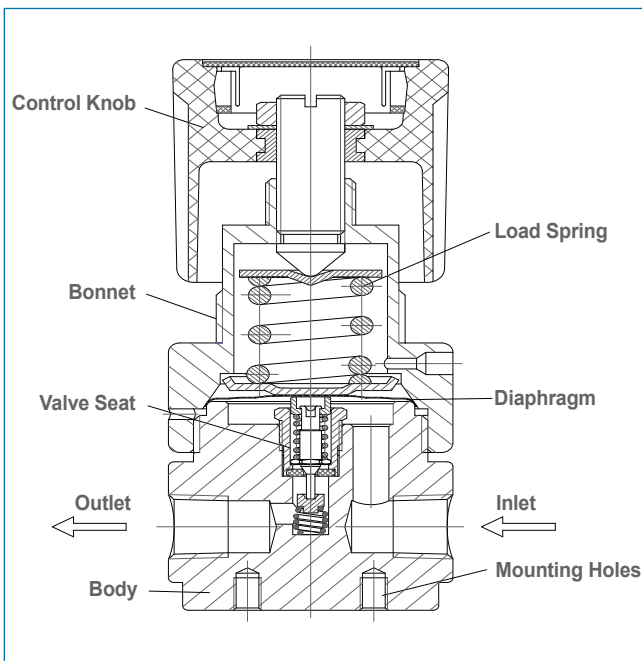

Dimensions

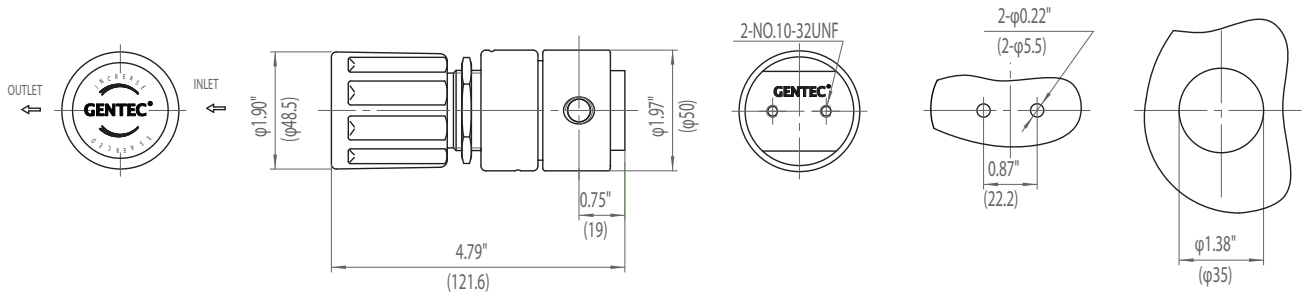

Rear Bracket Mount Front Panel Mount
Max. Thickness: 1/4" (7mm)

Flow Data

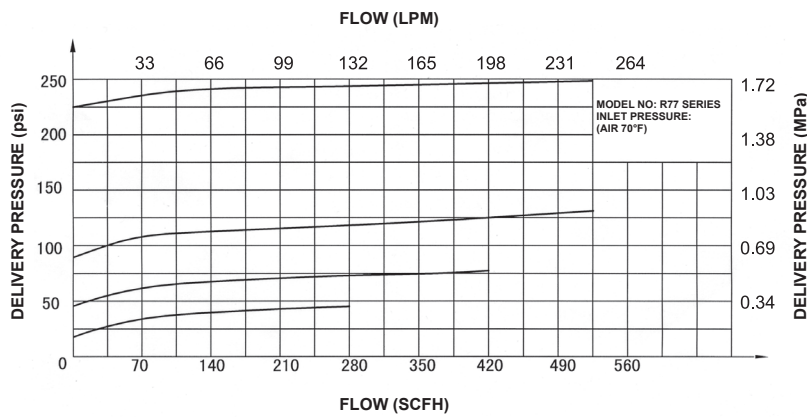

Body Port



Ordering Information

EX: R77SL	A	K -	G	W -	00 -	00 -	P
Series	Body Ports	Seat	Outlet Pressure Ranges	Gauge	Inlet Connections	Outlet Connections	Options
• R77SL	A	K: PCTFE	G: 0-250 psig I: 0-100 psig	K: Gauge W: No Gauge	00: 1/4" NPT(F) 01: 1/4" NPT(M)	00: 1/4" NPT(F) 01: 1/4" NPT(M)	P: Panel Mount

U21SL SERIES

Ultra High Purity Medium Flow Regulator

Specialty Gas Equipment

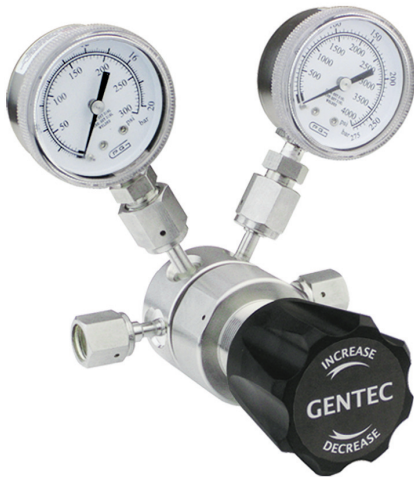

» U21SLGK-DGK-91-91-P

Materials

- Body 316L Stainless Steel
- Poppet 316 Stainless Steel
- Seat PCTFE
- Diaphragm 316L Stainless Steel
- Adjusting Knob ABS Plastic

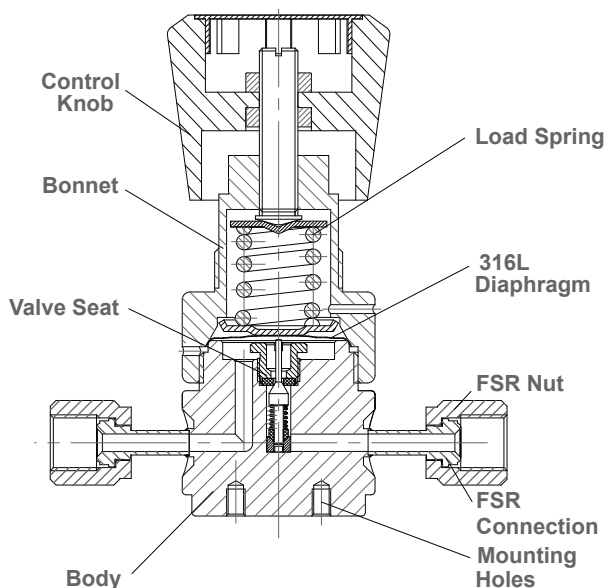

GENTEC® U21SL Series Single-Stage Stainless Steel Regulator is a hand adjustable, pressure reducing regulator designed for non-corrosive, corrosive, and toxic gas applications. Our metal-to-metal diaphragm to body seal is designed to minimize leakage and to provide excellent accuracy and longevity.

Product Features

- Single-Stage Configuration
- Metal-to-Metal Seal
- 2" Pressure Gauge
- Fully Internal Electropolished
- Cleaned, Assembled, and Packaged for High Purity Semiconductor Application
- 100% Helium-leak tested

Applications

- Semiconductor
- Solar
- Gas Panels
- OEM

Specifications

- **Maximum inlet pressure:** 500 psig (35 bar for B Port), 3000 psig (206 bar for A and G Port)
- **Maximum outlet pressure:** 500 psig
- **Safety test pressure:** 1.5 x Maximum inlet pressure
- **Temperature range:** -40°F~165°F (-40°C~ 74°C)
- **Inboard leakage:** 2×10^{-9} atm cc/sec He
- **Outboard leakage:** 2×10^{-9} atm cc/sec He
- **Leakage across seat:** 4×10^{-8} atm cc/sec He
- **Maximum Cv:** 0.14
- **Weight:** 3.8 lb

Dimensions

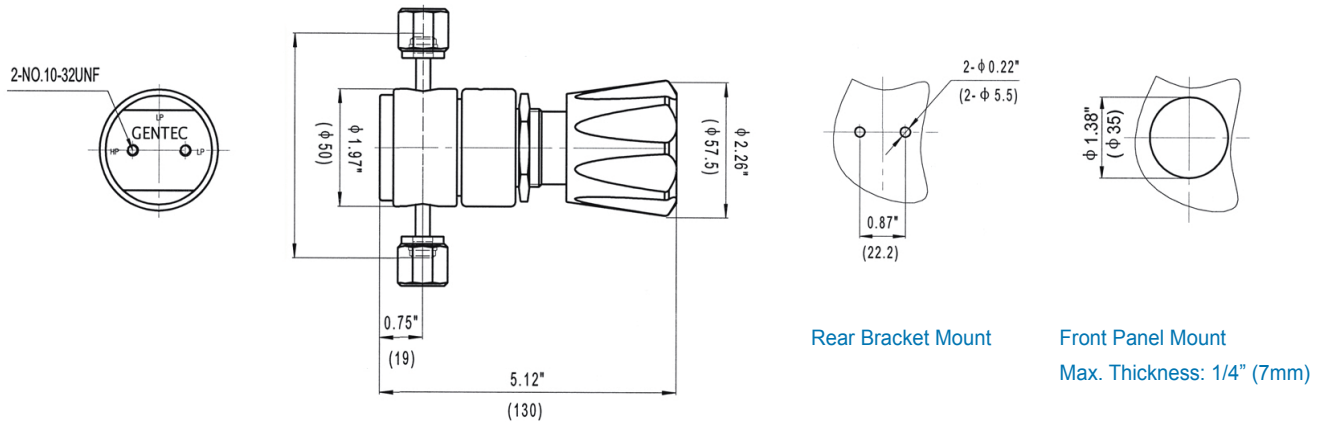

Flow Data

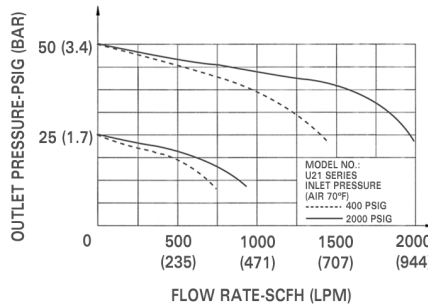
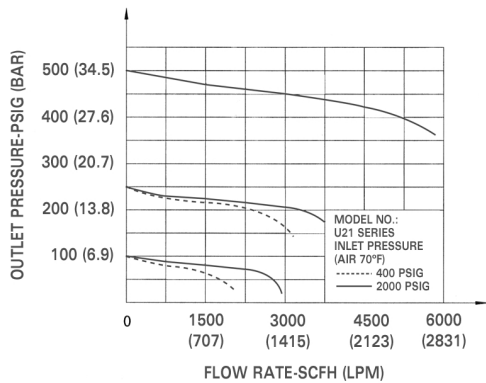

Body Ports

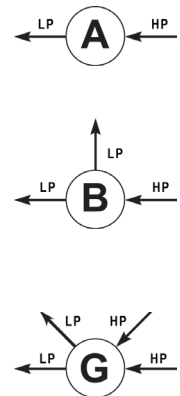

Ordering Information

EX:U21SL	G	K -	D	G	K -	91 - 91 -	P
Series	Ports	Seat	Inlet Pressure Ranges	Outlet Pressure Ranges	Gauge	Inlet / Outlet Connections	Options
• U21SL	A B G	K: PCTFE	D: 3000 psig F: 500 psig	F: 0-500 psig G: 0-250 psig I: 0-100 psig K: 0-50 psig L: 0-25 psig	K: Gauge W: No Gauge	90: 1/4" internal female FSR 91: 1/4" swivel female FSR 92: 1/4" swivel male FSR 41: 1/4" weld stub	E: Ra 10 μ m P: Panel Mounting H: Hastelloy® Diaphragm

U22SL SERIES

Ultra High Purity High Flow Regulator

Specialty Gas Equipment



» U22SLGK-DGK-95-95-P

Materials

- | | |
|------------------|----------------------------------|
| • Body | 316L Stainless Steel |
| • Poppet | 316L Stainless Steel, Hastelloy® |
| • Seat | PCTFE |
| • Diaphragm | 316L Stainless Steel |
| • Adjusting Knob | ABS Plastic |

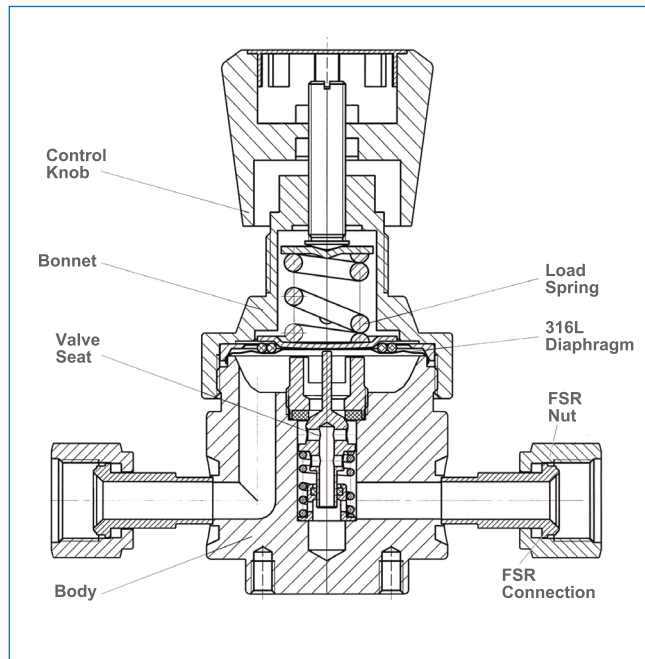

GENTEC® R22SL Series Stainless Steel Regulators is a purge gas, pressure reducing regulators. It is designed for non-corrosive, corrosive, and toxic gas applications. Our metal-to-metal diaphragm to body seal is designed to minimize leakage and to provide excellent accuracy and longevity.

Product Features

- Single-Stage Configuration
- Metal-to-Metal Seal
- 2" Pressure Gauge
- Fully Internal Electropolished
- Cleaned, Assembled, and Packaged for High Purity Semiconductor Application
- 100% Helium-leak tested

Applications

- Semiconductor
- Solar
- Gas Panels
- OEM

Specifications

- **Maximum inlet pressure:** 500 psig (35 bar for B Port), 3000 psig (206 bar for A and G Port)
- **Maximum outlet pressure:** 250 psig
- **Safety test pressure:** 1.5 x Maximum inlet pressure
- **Temperature range:** -40°F~165°F (-40°C~ 74°C)
- **Inboard leakage:** 2×10^{-8} atm cc/sec He
- **Outboard leakage:** 2×10^{-9} atm cc/sec He
- **Leakage across seat:** 4×10^{-8} atm cc/sec He
- **Maximum Cv:** 1.1
- **Weight:** 3.8 lb

Dimensions

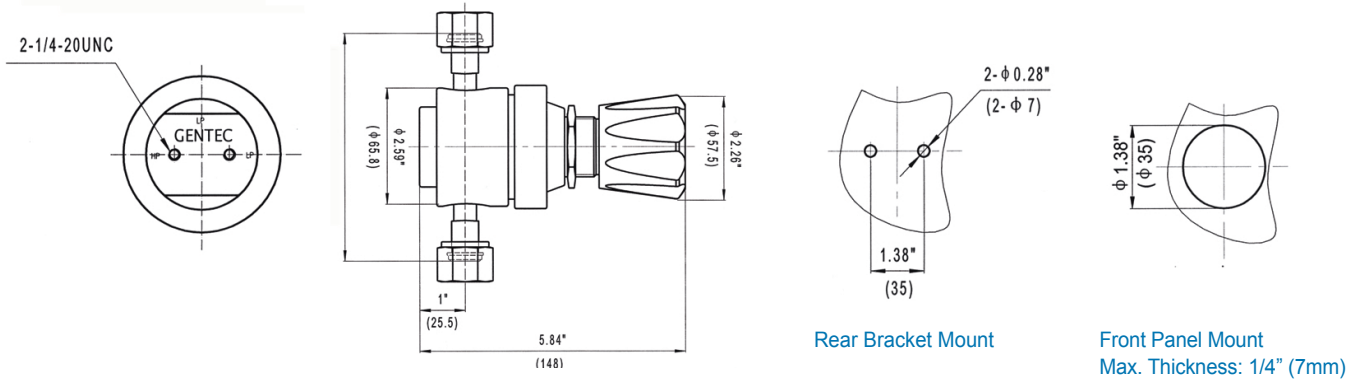

Flow Data

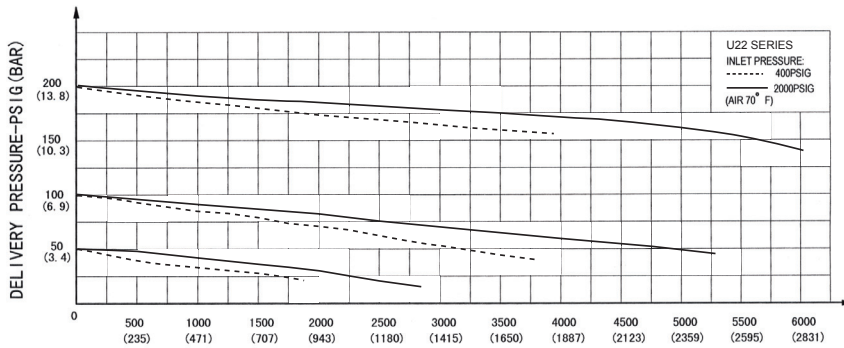

Body Ports

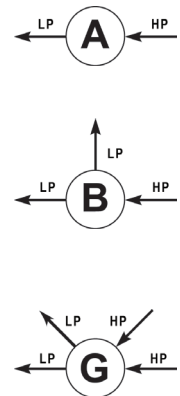

Ordering Information

EX:U22SL Series	G Ports	K - Seat	D Inlet Pressure Ranges	G Outlet Pressure Ranges	K - Gauge	95 - 95 - Inlet / Outlet Connections	P Options
• U22SL	A B G	K: PCTFE	D: 3000 psig F: 500 psig	G: 0-250 psig H: 0-150 psi I: 0-100 psig K: 0-50 psig L: 0-25 psig	K: Gauge W: No Gauge	95: 1/2" FSR(F) 96: 1/2" FSR(M)	E: Ra 10 μin P: Panel Mounting H: Hastelloy® Diaphragm

U23SL SERIES

Ultra High Purity High Flow Regulator

Specialty Gas Equipment



» U23SLGK-DHK-95-95-P

Materials

- Body 316L Stainless Steel
- Poppet 316 Stainless Steel
- Seat PCTFE
- Diaphragm 316L Stainless Steel
- Adjusting Knob ABS Plastic

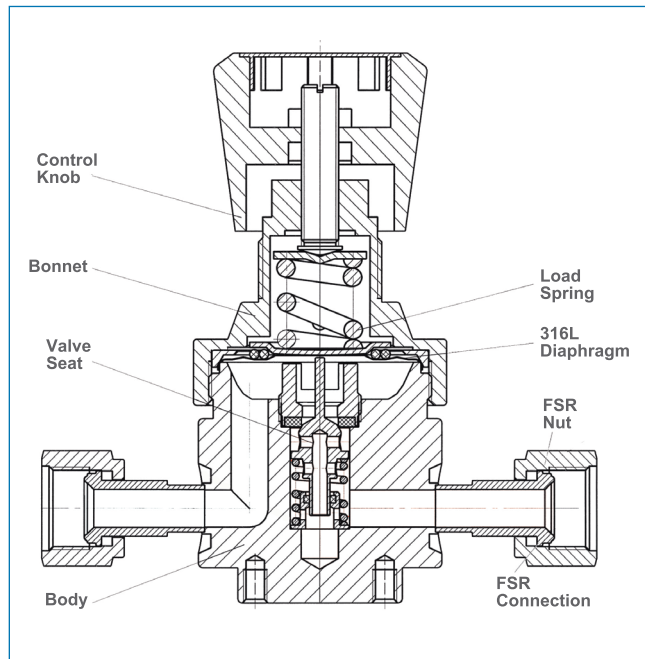

GENTEC® U23SL Series Stainless Steel Regulator is an ideal purge regulator for low pressure and high purity systems. It also works great with heavy duty gas flow applications. Our metal-to-metal diaphragm to body seal is designed to minimize leakage and to provide excellent accuracy and longevity.

Product Features

- Single-Stage Configuration
- Metal-to-Metal Seal
- 2" Pressure Gauge
- Fully Internal Electropolished
- Cleaned, Assembled, and Packaged for High Purity Semiconductor Application

Applications

- Semiconductor
- Solar
- Gas Panels
- OEM

Specifications

- **Maximum inlet pressure:** 500 psig (35 bar for B Port), 3000 psig (206 bar for A, G Ports)
- **Maximum outlet pressure:** 250 psig
- **Safety test pressure:** 1.5 x Maximum inlet pressure
- **Temperature range:** -40°F~165°F (-40°C~ 74°C)
- **Inboard leakage:** 2×10^{-9} atm cc/sec He
- **Outboard leakage:** 2×10^{-9} atm cc/sec He
- **Leakage across seat:** 4×10^{-8} atm cc/sec He
- **Maximum Cv:** 1.8
- **Weight:** 3.8 lb

Dimensions

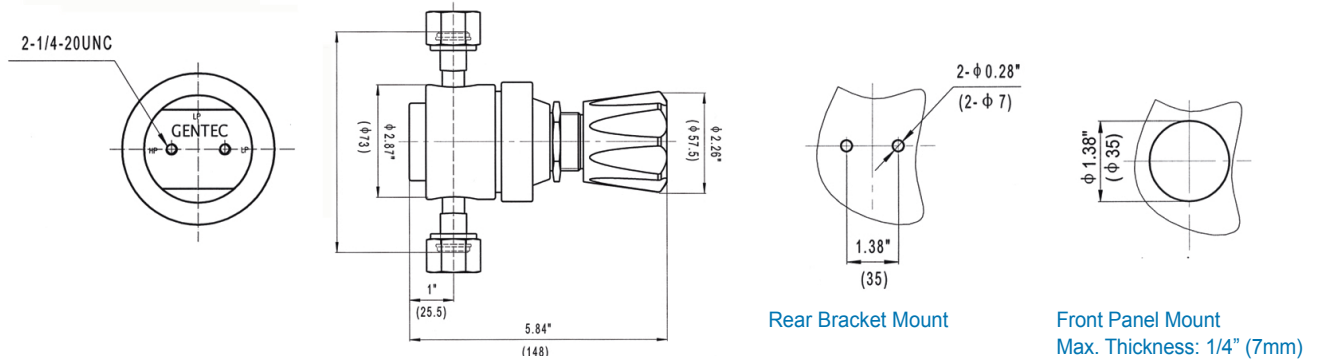

Flow Data

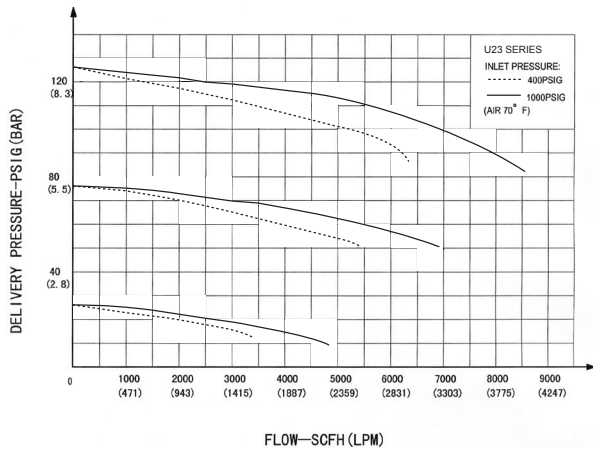

Body Ports

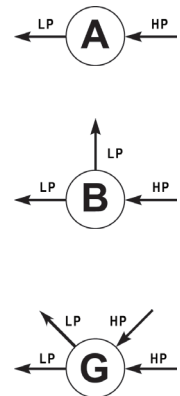

Ordering Information

EX:U23SL Series	G Ports	K - Seat	D Inlet Pressure Ranges	H Outlet Pressure Ranges	K - Gauge	95 - 95 - Inlet / Outlet Connection	P Options
• U23SL	A B G	K: PCTFE	D: 3000 psi F: 500 psi	G: 0-250 psi H: 0-150 psi I: 0-100 psi K: 0-50 psi L: 0-25 psi	K: Gauge W: No Gauge	95: 1/2" FSR(F) 96: 1/2" FSR(M)	E: Ra 10 μ m P: Panel Mounting H: Hastelloy® Diaphragm

U53SL SERIES

Ultra High Purity Low Flow Regulator

Specialty Gas Equipment



» U53SLGK-GLK-91-91

Materials

- **Body** 316L Stainless Steel
- **Poppet** 316 Stainless Steel
- **Seat** PCTFE
- **Diaphragm** 316L Stainless Steel
- **Adjusting Knob** ABS Elgiloy

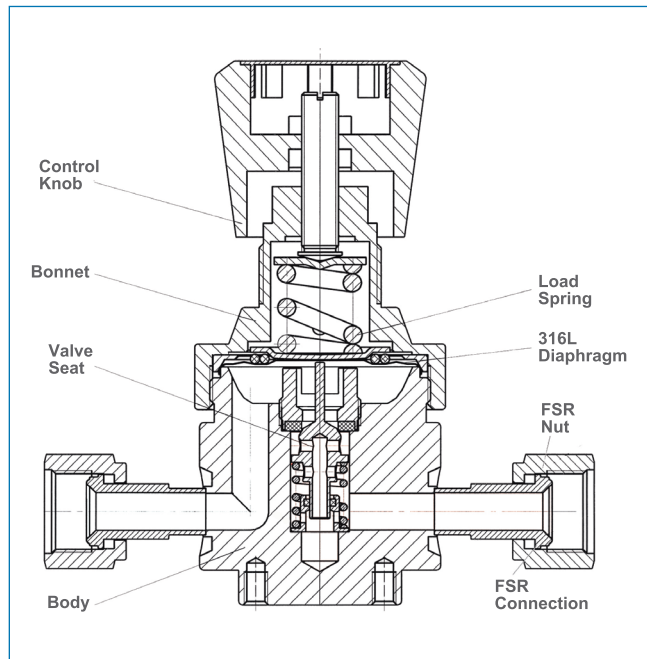

GENTEC® U53SL Series Stainless Steel Regulator is a threadless, high purity Regulator with non-tied diaphragm design. Our metal-to-metal diaphragm to body seal is designed to minimize leakage and to provide excellent accuracy and longevity.

Product Features

- Single-Stage Configuration
- Metal-to-Metal Seal
- 2" Pressure Gauge
- Fully Internal Electropolished
- Cleaned, Assembled, and Packaged for High Purity Semiconductor Application

Applications

- Semiconductor
- Solar
- Gas Panels
- OEM

Specifications

- **Maximum inlet pressure:** 300 psig
- **Maximum outlet pressure:** 30 psig
- **Safety test pressure:** 1.5 x Maximum inlet pressure
- **Temperature range:** -40°F~165°F (-40°C~ 74°C)
- **Inboard leakage:** 0.5×10^{-9} atm cc/sec He
- **Outboard leakage:** 1×10^{-9} atm cc/sec He
- **Leakage across seat:** 4×10^{-8} atm cc/sec He
- **Maximum Cv:** 0.054
- **Weight:** 3.8 lb

Dimensions

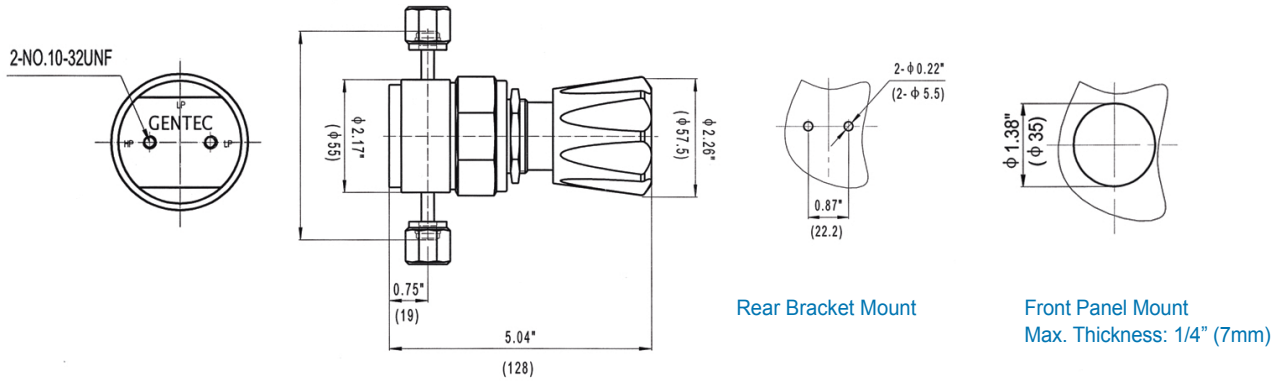

Flow Data

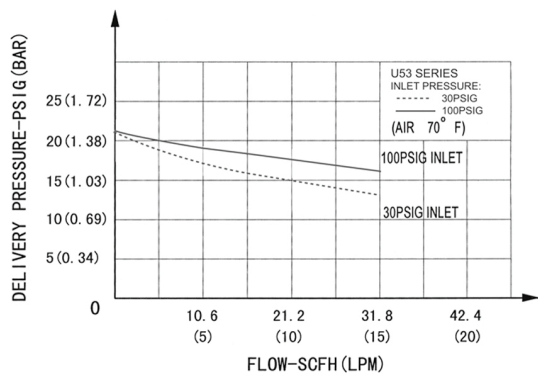

Body Ports

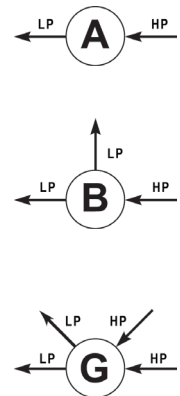

Ordering Information

EX: U53SL Series	G Ports	K - Seat	G Inlet Pressure Range	L Outlet Pressure Range	K - Gauge	91 - 91 - Inlet / Outlet Connections	Options
• U53SL	A B G	K: PCTFE	G: 300 psi	L: 0-30 psig	K: Gauge W: No Gauge	90: 1/4" internal female FSR 91: 1/4" swivel female FSR 92: 1/4" swivel male FSR 41: 1/4" weld stub	P: Panel Mounting H: Hastelloy® Diaphragm

ACCESSORIES

Regulator Protocol Station & Panel Mount

Specialty Gas Equipment

Regulator Protocol Station



Note: Gas Regulators not included with Protocol Station*.

- Designed to provide easy, safe, and fast cylinder exchanges by eliminating the direct connection between the gas regulator and cylinder
- Bracket Mount fits both Single and Dual-Stage Regulators
- Station Blocks are available in Chrome-Plated Brass and 316L Stainless Steel
- Pigtails are equipped with Anti-Whip/Anti-Kink Stainless Steel arm or casing

Panel Mount

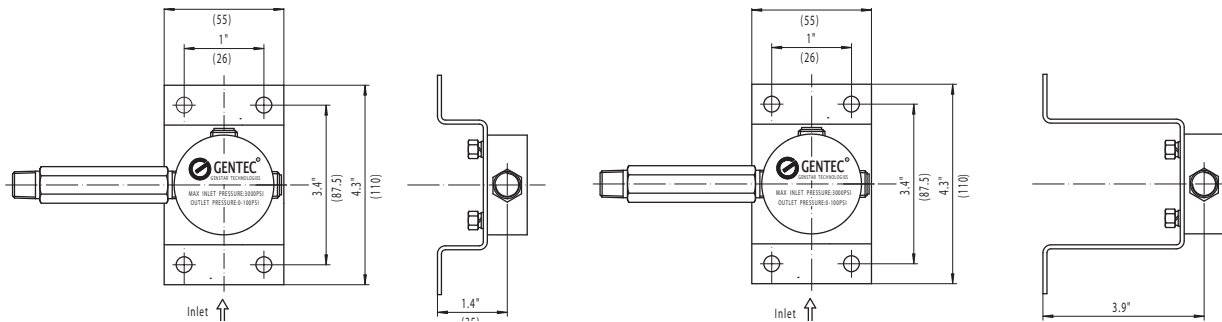

Series	Bracket Style	Inlet Pressure Range	Inlet Connections (on pigtail)	Outlet Connection (to regulator)	Check Valve	Pigtails (36")
PSSL: 316L PSB: Brass	W: Wall-Mount	D: 3000 psi	01: 1/4"NPT(M) 22: CGA320 23: CGA330 24: CGA350 Other Connections are available	01: 1/4"NPT(M)	CV: With Check Valve Leave blank for no check valves	S: 316L T: Teflon

Gauges

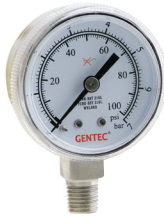

G20SL
Low Mount (LM)



GR20SL
Back Mount (BM)

Series	Specs.	Wetted	Casing	Connection
G20P (LM)		Brass	Nickel-Plated Brass	1/4" NPT
G20SL (LM)		316L	316L	1/4" NPT
GR20SL (BM)		316L	316L	1/4" NPT

2", PSI/kPa Dual Scale, Lower Mount			
Model Number		Maxium Scale PSI/kPa	Entry
Chrome Plated Brass	Stainless Steel		
G20PV-30-P/K	G20SLV-30-P/K	-30in.Hg/30/200	LM
G20PV-60-P/K	G20SLV-60-P/K	-30in.Hg/60/400	LM
G20PV-100-P/K	G20SLV-100-P/K	-30in.Hg/100/700	LM
G20PV-150-P/K	G20SLV-150-P/K	-30in.Hg/100/1000	LM
G20PV-200-P/K	G20SLV-200-P/K	-30in.Hg/200/1400	LM
G20PV-300-P/K	G20SLV-300-P/K	-30in.Hg/300/2000	LM
G20P-30-P/K	G20SL-30-P/K	30/200	LM
G20P-60-P/K	G20SL-60-P/K	60/400	LM
G20P-100-P/K	G20SL-100-P/K	100/700	LM
G20P-160-P/K	G20SL-160-P/K	160/1100	LM
G20P-200-P/K	G20SL-200-P/K	200/1400	LM
G20P-300-P/K	G20SL-300-P/K	300/2000	LM
G20P-600-P/K	G20SL-600-P/K	600/4000	LM
G20P-1000-P/K	G20SL-1000-P/K	1000/7000	LM
G20P-1500-P/K	G20SL-1500-P/K	1500/10000	LM
G20P-2000-P/K	G20SL-2000-P/K	2000/14000	LM
G20P-3000-P/K	G20SL-3000-P/K	3000/20000	LM
G20P-4000-P/K	G20SL-4000-P/K	4000/28000	LM
G20P-6000-P/K	G20SL-6000-P/K	6000/40000	LM

2", PSI/bar Dual Scale, Lower Mount			
Model Number		Maxium Scale PSI/bar	Entry
Chrome Plated Brass	Stainless Steel		
G20PV-30-P/B	G20SLV-30-P/B	-30in.Hg/30/2	LM
G20PV-60-P/B	G20SLV-60-P/B	-30in.Hg/60/4	LM
G20PV-100-P/B	G20SLV-100-P/B	-30in.Hg/100/7	LM
G20PV-150-P/B	G20SLV-150-P/B	-30in.Hg/150/10	LM
G20PV-200-P/B	G20SLV-200-P/B	-30in.Hg/200/14	LM
G20PV-300-P/B	G20SLV-300-P/B	-30in.Hg/300/20	LM
G20P-30-P/B	G20SL-30-P/B	30/200	LM
G20P-60-P/B	G20SL-60-P/B	60/400	LM
G20P-100-P/B	G20SL-100-P/B	100/7	LM
G20P-160-P/B	G20SL-160-P/B	160/11	LM
G20P-200-P/B	G20SL-200-P/B	200/14	LM
G20P-300-P/B	G20SL-300-P/B	300/20	LM
G20P-600-P/B	G20SL-600-P/B	600/40	LM
G20P-1000-P/B	G20SL-1000-P/B	1000/70	LM
G20P-1500-P/B	G20SL-1500-P/B	1500/100	LM
G20P-2000-P/B	G20SL-2000-P/B	2000/140	LM
G20P-3000-P/B	G20SL-3000-P/B	3000/200	LM
G20P-4000-P/B	G20SL-4000-P/B	4000/280	LM
G20P-6000-P/B	G20SL-6000-P/B	6000/400	LM

2", PSI/bar Dual Scale, Back Mount		
Model Number	Maxium Scale PSI/bar	Entry
Stainless Steel		
GR20SLV-30-P/B	-30in.Hg/30/2	BM
GR20SLV-60-P/B	-30in.Hg/60/4	BM
GR20SLV-100-P/B	-30in.Hg/100/7	BM
GR20SLV-150-P/B	-30in.Hg/150/10	BM
GR20SLV-200-P/B	-30in.Hg/200/14	BM
GR20SLV-300-P/B	-30in.Hg/300/20	BM
GR20SL-30-P/B	30/200	BM
GR20SL-60-P/B	60/400	BM
GR20SL-100-P/B	100/7	BM
GR20SL-160-P/B	160/11	BM
GR20SL-200-P/B	200/14	BM
GR20SL-300-P/B	300/20	BM
GR20SL-600-P/B	600/40	BM
GR20SL-1000-P/B	1000/70	BM
GR20SL-1500-P/B	1500/100	BM
GR20SL-2000-P/B	2000/140	BM
GR20SL-3000-P/B	3000/200	BM
GR20SL-4000-P/B	4000/280	BM
GR20SL-6000-P/B	6000/400	BM

Electronic Contact Gauges



GA20SL
Lower Mount (LM)



GRA20SL
Back Mount (BM)



GE20SL
Lower Mount (LM)



GRE20SL
Back Mount (BM)

- Contact: normally open (no pressure)
- Adjustable between 5 and 80% of the scale range
- Maximum power: 10 watts DC, 12 VAAC
- Maximum switch voltage: 28 V AC/DC
- Wetted area and casing: 316L
- Temperature: -40°F~158°F
- Connection: 1/4" NPT
- Accuracy: 3-2-3 (2%)
- Potential-free relay

2", Stainless Steel Contact Gauge, PSI/kPa Dual Scale				
Model Number				Maxium Scale PSI/kPa
Twist Cap		Fixed Cap		
Lower Mount	Back Mount	Lower Mount	Back Mount	
GA20SL-100-P/K	GRA20SL-100-P/K	GE20SL-100-P/K	GRE20SL-100-P/K	100/700
GA20SL-200-P/K	GRA20SL-200-P/K	GE20SL-200-P/K	GRE20SL-200-P/K	200/1400
GA20SL-300-P/K	GRA20SL-300-P/K	GE20SL-300-P/K	GRE20SL-300-P/K	300/2000
GA20SL-400-P/K	GRA20SL-400-P/K	GE20SL-400-P/K	GRE20SL-400-P/K	400/2800
GA20SL-600-P/K	GRA20SL-600-P/K	GE20SL-600-P/K	GRE20SL-600-P/K	600/4000
GA20SL-1500-P/K	GRA20SL-1500-P/K	GE20SL-1500-P/K	GRE20SL-1500-P/K	1500/10000
GA20SL-3000-P/K	GRA20SL-3000-P/K	GE20SL-3000-P/K	GRE20SL-3000-P/K	3000/20000
GA20SL-4000-P/K	GRA20SL-4000-P/K	GE20SL-4000-P/K	GRE20SL-4000-P/K	4000/28000

Note: Please consult factory on VCR/FSR gauges or Psi/bar and PSI/kPa dual scale ranges not listed.

ACCESSORIES

Needle Valves, Relief Valves & Diaphragm Valves

Specialty Gas Equipment

Needle Valves

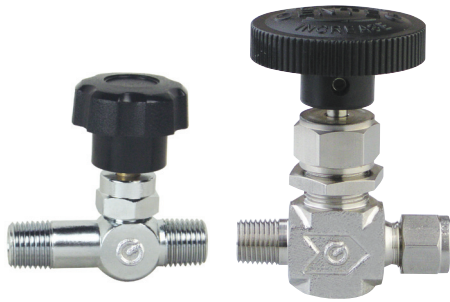

207CP

SS-NV12-NT4-TF4

- Designed for use with regulator
- Easy control of outlet flow

Series	Material	Max Working Pressure	Inlet / Outlet Connection
207CP	Nickel-Plated Brass	500 psig	1/4" NPT(M) x 1/4" NPT(M)
SS-NV12-NT4	316	5000 psig	1/4" NPT(M) x 1/4" NPT(M)
SS-NV12-NT4-TF4	316	5000 psig	1/4" NPT(M) x 1/4" GENLOK

Relief Valves



SS-RV11-100

- Designed for use with regulator
- Relief pressure adjustable

Series	Material	Pressure Range	Inlet / Outlet Connection
RV11	SS: 316	20: 10-20 psig	1/4" NPT(M) x 1/4" NPT(F)
	B: Nickel-Plated Brass	100: 20-100 psig	1/4" NPT(M) x 1/4" NPT(F)
		250: 100-250 psig	1/4" NPT(M) x 1/4" NPT(F)
		500: 250-500 psig	1/4" NPT(M) x 1/4" NPT(F)
		750: 500-750 psig	1/4" NPT(M) x 1/4" NPT(F)

Diaphragm Valves

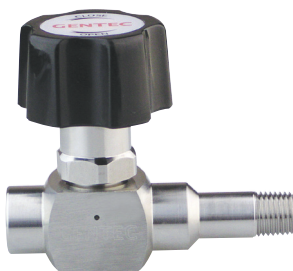

SL-DV92-NT4-FNT4

- Designed for regulator outlet port

Series	Cv	Max Working Pressure	Inlet / Outlet Connection
SL-DV92-NT4-FNT4	0.17	3500 psig	1/4" NPT(F) x 1/4" NPT(M)
BP-DV92-NT4-FNT4	0.17	3500 psig	1/4" NPT(F) x 1/4" NPT(M)

Please see "Valves" catalog for more information

Check Valves



Please contact GENTEC® for additional sizes or cracking pressure available

Model	Inlet Connection	Outlet Connection
SS-CV11-TF2-VI-1	1/8" GENLOK	1/8" GENLOK
SS-CV11-NT2-VI-1	1/8" NPT(M)	1/8" NPT(M)
SS-CV11-FNT2-VI-1	1/8" NPT(F)	1/8" NPT(F)
SS-CV11-TF4-VI-1	1/4" GENLOK	1/4" GENLOK
SS-CV11-NT4-TF4-VI-1	1/4" NPT(M)	1/4" GENLOK
SS-CV11-NT4-VI-1	1/4" NPT(M)	1/4" NPT(M)
SS-CV12-FNT4-VI-1	1/4" NPT(F)	1/4" NPT(F)

Material: 316L | Pressure Rating: 3000 psig | Cracking Pressure: 1 psig | Viton® O-rings standard

Filters



INLINE FILTER

T-TYPE FILTER

Please see "F Series Filters" catalog for more information

Type	Model	Inlet Connection	Outlet Connection
Inline Type	SS-F4-FNT2	1/8" NPT(F)	1/8" NPT(F)
	SS-F4-TF4	1/4" GENLOK	1/4" GENLOK
	SS-F4-NT4	1/4" NPT(M)	1/4" NPT(M)
T-Type	SS-F4T-FNT2	1/8" NPT(F)	1/8" NPT(F)
	SS-F4T-TF4	1/4" GENLOK	1/4" GENLOK
	SS-F4T-NT4	1/4" NPT(M)	1/4" NPT(M)

Material: 316 | Max. Working Pressure: 3000 psi for inline type, 6000 psi for T-type | Washer: 316L | Nominal Pore Size: 0.5-2 microns

Flashback Arrestors



FA33PH



FA34P

- Designed for use with low pressure manifold piping
- Preventing flashbacks from low to high pressure piping

Model No.	Material	Gas Service	Working Pressure	Delivery Flow	Inlet Connection	Outlet Connection
FA33PH	Stainless Steel	Flammable, Oxygen	50 psi	1250 SCFH	1/4"NPT(F)	1/4"NPT(F)
FA34P	Brass	Flammable	50 psi	1050 SCFH	1/4"NPT(F)	1/4"NPT(F)

Purge Tools

- Purge assembly is highly recommended when a toxic, corrosive, flammable or ultra high purity gas is used in a system.
- Purge assembly enables users to purge systems of contamination.



SL-P101

- Straight purge connection
- For connection to regulator's high pressure inlet
- For regulators and downstream devices
- Purge gases delivered from regulator's downstream
- Suitable for circular purging



SL-P102

- "T"-design purge connection
- For connection between regulator and cylinder
- Purge of whole gas system
- Purge gases delivered from regulator's downstream
- Suitable for circular purging

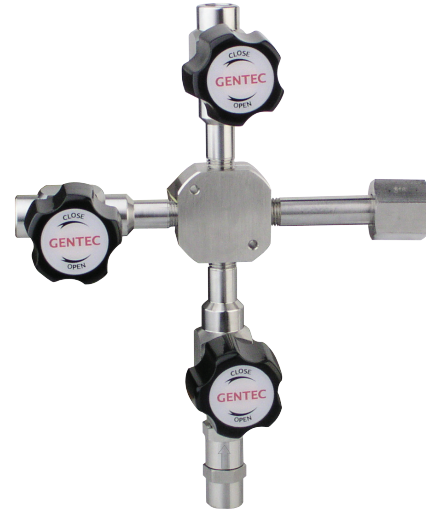

SL-P103

- Cross design purge connection
- For connection between regulator and cylinder
- Purge of whole gas system, diaphragm valve controls purging for cylinder valve
- Purge gases relieved from purged port of regulator's downstream

Series	Inlet Connections	Outlet Connections
SL-P101	00: 1/4" NPT(F)	00: 1/4" NPT(F)
SL-P102	01: 1/4" NPT(M)	01: 1/4" NPT(M)
SL-P103	C330: CGA330 C350: CGA350 C580: CGA580 C660: CGA660 C590: CGA590 Other connections are available	

Vacuum Generator



- 316L stainless steel construction
- Cleaned, welded assembled, tested and packaged in Class 10 clean room
- Internal surface finish 0.4 um
- 660 mmHg (100 Torr) vacuum generated with a minimum source nitrogen pressure of 75 psig
- Helium leak tested
- Used in gas delivery systems to assist in purging piping systems

EX: SL - Material	VG22 - Serial No.	VM4 - N2 Inlet	VM8 - Vent Connection	VSM4 Vacuum Connections	Connections
SL: 316L	VG22	VM4	VM8	VM4 VSM4 VSF4	VM4: 1/4" face seal male VM8: 1/2" face seal male VSM4: 1/4" face seal swivel male VSF4: 1/4" face seal swivel female

Tube Fittings



SS-MC-TF4-NT4



SS-UE-TF4

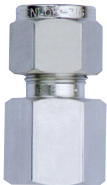

SS-FC-TF4-FNT4



R952-5503

Series	Material	Inlet/Outlet Connection
R195-51P	Nickel-Plated Brass	1/4" NPT(M) x 1/4" NPT(M), Connection
R952-5503	316 Stainless Steel	1/4" NPT(M) x 1/4" NPT(M), Connection
SS-MC-TF4-NT4	316 Stainless Steel	1/4" NPT(M) x 1/4" Genlok, Connection
SS-MC-TF6-NT4	316 Stainless Steel	3/8" NPT(M) x 1/4" Genlok, Connection
SS-MC-TF8-NT4	316 Stainless Steel	1/2" NPT(M) x 1/4" Genlok, Connection
SS-MC-TF8-NT8	316 Stainless Steel	1/2" NPT(M) x 1/2" Genlok, Connection
SS-MC-TF12-NT12	316 Stainless Steel	1/2" NPT(M) x 3/4" Genlok, Connection
SS-FC-TF2-FNT4	316 Stainless Steel	1/4" NPT(F) x 1/8" Genlok, Connection
SS-FC-TF4-FNT4	316 Stainless Steel	1/4" NPT(F) x 1/4" Genlok, Connection
SS-FC-TF6-FNT4	316 Stainless Steel	1/4" NPT(F) x 3/8" Genlok, Connection
SS-FC-TF8-FNT4	316 Stainless Steel	1/4" NPT(F) x 1/2" Genlok, Connection
R155-64JP	Nickel-Plated Brass	1/2" NPT(M) x 3/8" NPT(F), Straight
R155-64KP	Nickel-Plated Brass	1/2" NPT(M) x 3/8" NPT(M), Straight
R155-64EP	Nickel-Plated Brass	1/2" NPT(M) x 1/2" NPT(M), Straight
R982-5502	316 Stainless Steel	1/2" NPT(M) x 3/8" NPT(F), Straight
R982-5507	316 Stainless Steel	1/2" NPT(M) x 3/8" NPT(M), Straight
R982-5506	316 Stainless Steel	1/2" NPT(M) x 1/2" NPT(M), Straight
SS-UE-TF4	316 Stainless Steel	1/4" Genlok x 1/4" Genlok, Elbow
SS-UE-TF8	316 Stainless Steel	1/2" Genlok x 1/2" Genlok, Elbow

Please see "Tube Fittings" catalog for more information

Cylinder Connection Table

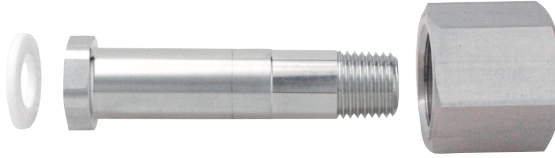

• Nuts and nipples are designed for regulator inlet connections.

BS341	Model No.	Material	Nut	Nipple	Washer
NO. 2	SS-BS341-2	Stainless Steel	G5/8-14	3" Length	
	BP-BS341-2	Brass / Nickel-Plated	(Left Hand)	(1/4" NPT)	
NO. 3	SS-BS341-3	Stainless Steel	G5/8-14	3" Length	
	BP-BS341-3	Brass / Nickel-Plated	(Right Hand)	(1/4" NPT)	
NO. 4	SS-BS341-4	Stainless Steel	G5/8-14	3" Length	
	BP-BS341-4	Brass / Nickel-Plated	(Left Hand)	(1/4" NPT)	
DIN477	Model No.	Material	Nut	Nipple	Washer
NO. 5	SS-DIN477-5	Stainless Steel	1"-11	2-1/2" Length	Nylon
	BP-DIN477-5	Brass / Nickel-Plated	(Left Hand)	(1/4" NPT)	
NO. 6	SS-DIN477-6	Stainless Steel	W21.8-14	2.35" Length	Nylon
	BP-DIN477-6	Brass / Nickel-Plated	(Right Hand)	(1/4" NPT)	
NO. 8	SS-DIN477-8	Stainless Steel	1"-11	2.35" Length	PTFE
	BP-DIN477-8	Brass / Nickel-Plated	(Right Hand)	(1/4" NPT)	
CGA	Model No.	Material	Nut	Nipple	Washer
330	SS-CGA330	Stainless Steel	0.830-14NGO	2" Length	Nylon
	BP-CGA330	Brass / Nickel-Plated	(Left Hand)	(1/4" NPT)	
350	SS-CGA350	Stainless Steel	0.830-14NGO	2-1/2" Length	Nylon
	BP-CGA350	Brass / Nickel-Plated	(Left Hand)	(1/4" NPT)	
580	SS-CGA580	Stainless Steel	0.960-14NGO	3" Length	
	BP-CGA580	Brass / Nickel-Plated	(Right Hand)	(1/4" NPT)	
590	SS-CGA590	Stainless Steel	0.960-14NGO	3" Length	Nylon
	BP-CGA590	Brass / Nickel-Plated	(Left Hand)	(1/4" NPT)	
660	SS-CGA660	Stainless Steel	1.035-14NGO	2" Length	Nylon
	BP-CGA660	Brass / Nickel-Plated	(Right Hand)	(1/4" NPT)	

* Note: More connections available upon request.

Wall-Mount & Cylinder Brackets



SS-GMB-7G



GMB-1



GMB-3

Model Number	Inlet / Outlet Connection
GMB-1	Cylinder Wall Mount: 9"
GMB-3	Cylinder Wall Mount: 14"
SS-GMB-7G	Wall Mount Bracket: 1/2"
SS-GMB-7H	Wall Mount Bracket: 3/8"
SS-GMB-7I	Wall Mount Bracket: 1/4"

Pigtails

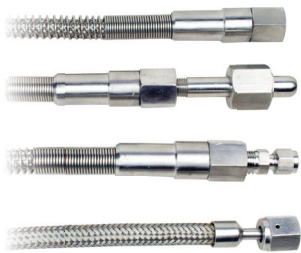

- Designed for use between cylinder and piping system
- Max. Pressure: GFPT and GFPS Series, 3000 psi; GRPS Series, 4500 psi
- Temp. Range: GFPS and GRPS Series, -325°F to 850°F (-200°C to 454°F); GFPT, -65°F to 450°F (-53°C to 230°C)
- Oxygen Service: Meets CGA G4.1 Specifications for cleanliness

GRPS - Series	C330 - Inlet Connections	CV - Options	00 - Outlet Connections
GRPS: Stainless Steel Rigid Pigtail	00: 1/4" NPT(F) C330: CGA330 C350: CGA350 C510: CGA510 C540: CGA540 C580: CGA580 C660: CGA660	Blank: None CV: with Check Valve FA: with Flashback Arrestor	00: 1/4" NPT(F) VF: 1/4" Female FSR OD: 1/4" Tube

GFPT Series	24 - Length	C330 - Inlet Connections	CV - Options	00 Outlet Connections
GFPT: Stainless Steel Flexible Pigtail with Teflon Insert	24: 24" 36: 36"	00: 1/4" NPT(F) C330: CGA330 C350: CGA350 C510: CGA510 C540: CGA540 C580: CGA580 C660: CGA660	Blank: None CV: with Check Valve FA: with Flashback Arrestor	00: 1/4" NPT(F)
GFPS: Stainless Steel Flexible Pigtail with Stainless Steel Insert				

MATERIALS OF CONSTRUCTION

GENTEC® Gas Regulators

Specialty Gas Equipment

Regulator	Application	Material								Type				Catalog Page
		Body		Diaphragm				Type		Other				
		FBR	BR	SS	N	SS	P	HS	Single Stage		Dual Stage	Line		
G152	General Purpose	•			•					•				08.
G152T	General Purpose	•			•						•			10.
HP152L	High Purity	•				•						•		12.
HP152	High Purity	•				•				•				14.
HP152T	High Purity	•				•					•			16.
R21B	High Purity		•			•						•		18.
R21SL	High Purity			•		•						•		26.
R21B	High Purity		•			•				•				20.
R21SL	High Purity			•		•				•				28.
R22B	High Purity, High Flow		•			•				•				22.
R22SL	High Purity, Medium Flow			•		•				•				30.
R31B	High Purity		•			•					•			24.
R31SL	High Purity			•							•			32.
R44SL	High Pressure			•				•		•				34.
R45SL	Ultra High Pressure			•				•		•				36.
R51SL	High Purity, Corrosion			•					•	•			FSR	38.
R77SL	Back Pressure			•		•				•				40.
U21SL	Ultra High Purity			•		•				•		•	FSR	42.
U22SL	Ultra High Purity			•		•				•		•	FSR	44.
U23SL	Ultra High Purity			•		•				•		•	FSR	46.
U53SL	Ultra High Purity			•		•						•	FSR	48.

FBR = Forged Brass BR = Brass Barstock SS = Stainless Steel N = Neoprene P = Piston HS = Hastelloy FSR = Face Seal

Pure Gases	Line Regulator	Cylinder Regulators		
	Single Stage	Single Stage	Dual Stage	CGA Inlet
ACETYLENE • Atomic absorption 99.6%		G152		510
AIR • Dry • Hydrocarbon Free • Zero	HP152L R21B/HP152L HP152L	G152 R21B/HP152 HP152	G152T R31B/HP152T HP152T	590
AMMONIA • Anhydrous		R21SL	R31SL	705
ARGON • Research 99.9995% • U.H.P. 99.999% • Prepurified 99.998% • Zero 99.998% • High Purity 99.995%	R21B R21B/HP152L HP152L HP152L	R21B R21B/HP152 HP152 G152	R31B R31B/HP152T HP152T G152T	580
BORON TRIFLUORIDE • Minimum Purity 99.5%		R21SL	R31SL	330
1.3 BUTADIENE • Instrument 99.5% • C.P. 99.0%		G152 G152	G152T G152T	510
N-BUTANE • Research 99.9% • C.P. 99.0%		R21B G152	R31B G152T	510
CARBON DIOXIDE • Research 99.998% • Instrument (Coleman) 99.99% • C.P. 99.8%	R21B HP152L HP152L	R21B HP152 G152	R31B HP152T G152T	320
CARBON MONOXIDE • Ultra High Purity 99.9% • C.P. 99.0% • Commercial 98.0%		HP152 G152	HP152T G152T	350
CHLORINE • High Purity 99.5%		R21SL	R31SL	660
DEUTERIUM • C.P. 99.5%		R21B	R31B	350
DIMETHYL ETHER • Purity 99.5%		R21B	R31B	510
ETHANE • Research 99.98% • C.P. 99.0% • Technical 98.55%		R21B G152 G152	R31B G152T G152T	350
ETHYLENE • Research 99.98% • C.P. 99.5% • Technical		R21B HP152 G152	R31B HP152T G152T	350
HELIUM • Research 99.9995% • Ultra High 99.999% • Zero 99.995% • High Purity 99.995%		R21SL R21B R21B R21B	R31SL R31B R31B R31B	580

GAS SERVICE

Line Regulators & Cylinder Regulators

Specialty Gas Equipment

Pure Gases	Line Regulator		Cylinder Regulators		
	Single Stage	Single Stage	Dual Stage	CGA Inlet	
HYDROGEN					
<ul style="list-style-type: none"> • Research 99.9999% • Ultra High 99.999% • Zero 99.99% • Prepurified 99.99% • Extra Dry 99.95% 		R21SL R21B R21B HP152	R31SL R31B R31B HP152T		350
HYDROGEN CHLORIDE					
<ul style="list-style-type: none"> • Chemical 99.0% 		R21SL/R51SL	R31SL/R51SL		330
KRYPTON					
<ul style="list-style-type: none"> • Research 99.995% 		R21SL	R31SL		580
METHANE					
<ul style="list-style-type: none"> • Research 99.99% • U.H.P. 99.97% • C.P. 99.0% • Technical 98.0% • Commerical 93.0% 		R21SL R21B HP152 G152 G152	R31SL R31B HP152T G152T G152T		350
NEON					
<ul style="list-style-type: none"> • Research 99.999% • U.H.P. 99.996% • Purified 99.89% 		R21SL R21SL R21SL	R31SL R31SL R31SL		580
NITROGEN					
<ul style="list-style-type: none"> • Research 99.9995% • Ultra High 99.999% • Prepurified 99.998% • Zero 99.998% • High Purity 99.99% • Oxygen Free 99.99% • Extra Dry 99.7% 	R21SL R21B R21B R21B R21B HP152	R21SL R21B R21B R21B R21B G152	R31SL R31B R31B R31B R31B G152T		580
NITROUS OXIDE					
<ul style="list-style-type: none"> • U.H.P. 99.99% • Atomic Absorption 99.0% 		R21B G152	R31B G152T		326
OXYGEN					
<ul style="list-style-type: none"> • Research 99.995% • U.H.P. 99.99% • Zero 99.6% • Extra Dry 99.6% 		R21SL R21B R21B R21B	R31SL R31B R31B R31B		540
PROPANE					
<ul style="list-style-type: none"> • Research 99.99% • Instrument 99.5% • C.P. 99.0% • Natural 96.0% 		R21B R21B G152 G152	R31B R31B G152T G152T		510
PROPYLENE					
<ul style="list-style-type: none"> • Research • C.P. 99.0% 		R21B G152	R31B G152T		510
SULFUR HEXAFLUORIDE					
<ul style="list-style-type: none"> • Instrument 99.99% • C.P. 99.8% 		R21B G152	R31B G152T		590
XENON					
<ul style="list-style-type: none"> • Research 99.995% 		R21SL	R31SL		580

Mixed Gases	Line Regulator	Cylinder Regulators		
	Single Stage	Single Stage	Dual Stage	CGA Inlet
AMMONIA				
• in Helium		R21SL	R31SL	
• in Air		R21SL	R31SL	705
• in Nitrogen		R21SL	R31SL	
ARGON				
• in Helium		R21B	R31B	580
• in Hydrogen		R21B	R31B	350
• in Nitrogen		R21B	R31B	580
BUTANE				
• in Air		R21B	R31B	590
• in Helium		R21B	R31B	580
• in Hydrogen		R21B	R31B	350
• in Nitrogen		R21B	R31B	590
CARBON DIOXIDE				
• in Air		R21B	R31B	590
• in Helium		R21B	R31B	580
• in Hydrogen		R21B	R31B	350
• in Nitrogen		R21B	R31B	580
• in Oxygen		R21B	R31B	296
CARBON MONOXIDE				
• in Air		R21B	R31B	590
• in Argon		R21B	R31B	350
• in Helium		R21B	R31B	350
• in Hydrogen		R21B	R31B	350
• in Nitrogen		R21B	R31B	350
CHLORINE				
• in Helium		R21SL	R31SL	
• in Nitrogen		R21SL	R31SL	660
ETHANE				
• in Air		R21B	R31B	590
• in Helium		R21B	R31B	350
• in Nitrogen		R21B	R31B	350
ETHYLENE				
• in Air		R21B	R31B	590
• in Helium		R21B	R31B	350
• in Nitrogen		R21B	R31B	350
HELIUM				
• in Argon		R21B	R31B	580
• in Nitrogen		R21B	R31B	580
HEXANE				
• in Air		R21B	R31B	590
• in Helium		R21B	R31B	350
• in Nitrogen		R21B	R31B	350
HYDROGEN				
• in Argon		R21B	R31B	350
• in Air		R21B	R31B	590
• in Nitrogen		R21B	R31B	350

Mixed Gases	Line Regulator	Cylinder Regulators		
	Single Stage	Single Stage	Dual Stage	CGA Inlet
HYDROGEN CHLORIDE				
• in Nitrogen		R21SL	R31SL	330
HYDROGEN SULFIDE				
• in Air		R21SL	R31SL	660/330
• in Helium		R21SL	R31SL	330
• in Nitrogen		R21SL	R31SL	330
ISOBUTANE				
• in Air		R21B	R31B	590
• in Helium		R21B	R31B	350
• in Nitrogen		R21B	R31B	350
METHANE				
• in Air		R21B	R31B	590
• in Argon		R21B	R31B	350
• in Helium		R21B	R31B	350
• in Hydrogen		R21B	R31B	350
• in Nitrogen		R21B	R31B	350
NITRIC OXIDE				
• in Argon		R21SL	R31SL	660
• in Nitrogen		R21SL	R31SL	
NITROGEN				
• in Argon		R21B	R31B	580
• in Helium		R21B	R31B	580
• in Oxygen		R21B	R31B	296
NITROGEN DIOXIDE				
• in Air		R21SL	R31SL	660
• in Nitrogen		R21SL	R31SL	
OXYGEN				
• in Argon		R21B	R31B	
• in Helium		R21B	R31B	580/590
• in Nitrogen		R21B	R31B	
PROPANE				
• in Air		R21B	R31B	590
• in Hydrogen		R21B	R31B	350
• in Nitrogen		R21B	R31B	350
PROPYLENE				
• in Air		R21B	R31B	590
• in Nitrogen		R21B	R31B	350
SULFUR DIOXIDE				
• in Air		R21SL	R31SL	
• in Argon		R21SL	R31SL	
• in Helium		R21SL	R31SL	660
• in Nitrogen		R21SL	R31SL	

Instrument Mixtures	Line Regulator	Cylinder Regulators		
	Single Stage	Single Stage	Dual Stage	CGA Inlet
CHROMATOGRAPH CARRIER GAS 8.5% Hydrogen 91.5% Helium		R21B	R31B	350
ELECTRON CAPTURE MIXTURE P-5 Gas Mixture 5% Methane in Argon		R21B	R31B	350
FLAME IONIZATION FUEL MIXTURES 40% Hydrogen 60% Nitrogen		R21B	R31B	350
FURNACE ATMOSPHERE MIXTURES 40% Carbon Dioxide 60% Carbon Monoxide		R21B	R31B	350
NUCLEAR COUNTER MIXTURE 0.95% ISO Butane 99.05% Helium		HP152	HP152T	350
LEAK DETECTION MIXTURE 1-10% Helium in Nitrogen		R21B	R31B	580

Nuclear Counter Mixture	Line Regulator	Cylinder Regulators		
	Single Stage	Single Stage	Dual Stage	CGA Inlet
P-10 GAS MIXTURE 10% Methane 90% Argon		R21B	R31B	350
PROPORTIONAL COUNTING MIXTURE 4% ISO Butane 96% Helium		R21B/HP152	R31B	350
1.5% ISO Butane 98.5% Helium		R21B	R31B	350

MATERIAL COMPATIBILITY

A GENTEC® Product Material Compatibility

Specialty Gas Equipment

Gas	Material											
	Aluminum	Brass	Copper	Mone	Stainless Steel	Carbon Steel	Neoprene	PCTFE (Kel-F)	Viton	Polyethyler	PVC	PTFE (Teflon)
Ammonia	•	○	○	●	•	○	•	•	○	○	•	•
Argon	•	•	•	•	•	•	•	•	•	•	•	•
CO ₂	•	•	•	•	•	•	•	•	•	•	•	•
Chlorine	○	○	○	•	●	•	○	•	•	•	○	•
Diborane	•	•	•	•	•	•	○	•	•	○	○	•
Helium	•	•	•	•	•	•	•	•	•	•	•	•
Hydrogen	•	•	•	•	•	•	•	•	•	•	•	•
HCl	○	○	○	•	●	○	•	•	•	•	•	•
H ₂ S	●	○	○	●	•	○	○	•	•	•	•	•
Methane	•	•	•	•	•	•	•	•	•	•	•	•
Nitrogen	•	•	•	•	•	•	•	•	•	•	•	•
N ₂ O	•	•	•	•	•	•	•	•	•	•	•	•
Oxygen	•	•	•	•	•	•	•	•	•	○	○	•
Phosphine	•	○	○	•	•	•	○	•	•	•	•	•
Silane	•	•	•	•	•	•	•	•	•	•	•	•
SO ₂	•	•	●	•	•	•	○	•	○	•	•	•
F ₂ S	•	•	•	•	•	•	•	•	•	•	•	•
Arsine	○	•	○	•	•	•	•	•	•	•	•	•
Boron Trichloride	○	○	•	•	•	•	○	•	•	○	•	•
Boron Trifluoride	•	○	•	•	•	•	○	•	○	○	•	•
Dichlorosilane	○	○	○	•	•	•	○	•	○	○	○	•
Silicon Tetrachloride	○	○	○	•	•	•	○	•	○	○	○	•
Acetylene	•	•	○	•	•	•	•	•	•	•	○	•
Air	•	•	•	•	•	•	•	•	•	•	•	•
Butane	•	•	•	•	•	•	•	•	•	○	•	•
Carbon Monoxide	•	•	•	•	•	•	○	•	•	•	•	•
Cyclopropane	•	•	•	•	•	•	•	•	•	•	•	•
Ethane	•	•	•	•	•	•	•	•	•	•	•	•
Ethylene	•	•	•	•	•	•	•	•	•	•	○	•
Ethylene Oxide	•	•	•	•	•	•	○	•	○	○	○	•
Isobutane	•	•	•	•	•	•	•	•	•	○	•	•
Krypton	•	•	•	•	•	•	•	•	•	•	•	•
Methyl Chloride	○	○	●	•	•	•	•	•	•	•	○	•
Neon	•	•	•	•	•	•	•	•	•	•	•	•
NO	•	○	○	○	•	●	○	•	•	•	•	•
Propane	•	•	•	•	•	•	•	•	•	•	•	•
Xenon	•	•	•	•	•	•	•	•	•	•	•	•

• Recommended ○ Not Recommended ● Recommended only for dry-grades of gas

Gas	BSP	DIN	CGA	UHP CGA	JIS
Acetylene	BS341 nr. 2	==	510	==	==
Air	BS341 nr. 3	==	346	==	==
Ammonia	BS341 nr. 10	DIN6	705	720	22-R
Argon	BS341 nr. 3	DIN6	580	718	22-4 or 23-R
Arsine	==	==	350	632	22-L
Boron Trichloride	==	DIN8	660	634	==
Boron Trifluoride	==	DIN8	330	642	22-L
Butane	BS341 nr. 4	==	510	==	==
Carbon Dioxide	BS341 nr. 8	DIN6	320	716	==
Carbon Monoxide	BS341 nr. 4	DIN5	350	724	22-L
Cyclopropane	BS341 nr. 4	==	510	==	==
Diborane	==	==	350	632	22-L
Dichlorosilane	==	DIN5	678	636	==
Diethylzinc	==	==	510	726	==
Ethane	==	==	350	==	==
Ethyl Chloride	==	==	510	==	==
Ethylene	==	==	350	==	==
Ethylene Oxide	==	==	510	==	==
Germane	==	==	350 or 660	632	==
R11 (R116) / Halocarbon 11 (116)	==	==	660	716	==
R12 (R13, R23, R115) / Halocarbon 12 (13, 23, 115)	==	DIN6	660	716	==
R14 (Halocarbon 14)	==	DIN6	320 or 580	716	==
Helium	BS341 nr. 3	DIN6	580	718	22-R or 23-L
Hydrogen	BS341 nr. 2	DIN1	350	724	22-L
Hydrogen Chloride	==	DIN8	330	634	26-R
Hydrogen Fluoride	==	==	660 or 670	638	26-R
Hydrogen Sulfide	==	DIN5	330	722	==
Iso-Butane	==	==	510	==	==
Krypton	==	DIN6	580	718	22-R or 23-R
Methane	BS341 nr. 2	==	350	==	==
Methyl Chloride	==	==	660	==	==
Natural Gas	==	==	350	==	==
Neon	==	DIN6	580	718	22-R or 23-R
Nitric Oxide	==	==	660	==	==
Nitrogen	BS341 nr. 3	DIN10	580	718	22-R or 23-R
Nitrogen Trifluoride	==	DIN8	330 or 670	640	==
Nitrous Oxide	BS341 nr. 13	DIN9	326	712	==
Oxygen	BS341 nr. 3	DIN1	540	714	22-R or 23-R
Phosphine	==	==	350	632	==
Propane	BS341 nr. 4	==	510	==	==
Silane	==	==	350	632	==
Silicon Tetrachloride	==	==	330	636	==
Silicon Tetrafluoride	==	==	330	642	22-L
Sulfur Hexafluoride	==	DIN6	590	716	26-R
Tungsten Hexafluoride	==	DIN8	670	638	
Xenon	==	DIN6	580	718	22-R

*Chart is for reference only

WARRANTY

A GENTEC® Warranty Information

Specialty Gas Equipment

Any GENTEC® apparatus found to be defective either in material or workmanship during the time set forth below will be replaced by Genstar Technologies Company, Incorporated or its Authorized Distributors, provided that said apparatus was used under normal conditions for the purpose intended.

GENTEC® apparatus damaged or rendered inoperative due to abuse, negligence, misuse, accident or abnormal wear and tear is not covered by this warranty and must be repaired at the sole expense of the equipment owner. GENTEC® apparatus should be serviced facilities only. Service or repair of this apparatus by other than Genstar Technologies Company, Incorporated or designated service facilities may void any warranties and relieve Genstar Technologies Company, Incorporated of any claims for damage and/or liability.

To make a claim under this warranty, Buyer must notify Genstar Technologies Company, Incorporated or its Authorized Distributor of the details of such claim within 30 days of discovering a defect in material or workmanship along with proof of purchase. The Buyer will be responsible for transportation costs and related risks.

Genstar Technologies Company, Incorporated shall not, under any circumstances, be liable for any damages including but not limited to: indirect, incidental, consequential, or special damages, wether such damages result from negligence, breach of warranty or otherwise.

There are no other warranties, expressed or implied, except as stated herein. This warranty gives you specific legal rights, and you may also have other rights which vary from state to state. Genstar Technologies company, Incorporated reserves the right to dicontinue manufacturing of any product or change product materials, design or specifications without notice.

Warranty from the Date of Original Purchase



GENTEC®
High
Purity
Regulators

• 90 days in
corrosive service



Pigtaills



* GENTEC® Industrial Manifold Systems are not included in this catalog.

• Please refer to GENTEC® MANIFOLD SYSTEM catalog (Catalog No. MC 200802)

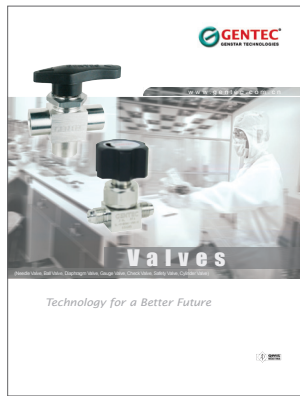

Valves

- Needle Valves
- Ball Valves
- Diaphragm Valves
- Cylinder Valves
- Gauge Valves
- Check Valves

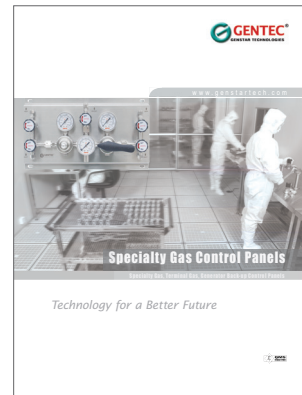

Specialty Gas Control Panel

- Specialty Gas Control Panel
- Terminal Gas Control Panel
- Generator Back-up Control Panel
- Accessories



Tube Fittings

- Male Connectors
- Male Elbows
- Male Adapters
- Female Connectors
- Female Elbows
- Unions
- Reducing unions



F Series Filters

- Inline Filter
- T-type Filter

.....
Please contact us for any questions about catalogs.

- Requesting Catalogs
 - Register an account to view / download pdf catalogs. (Online Register)
-

To view our full line of Specialty Gas Products please visit us online at www.genstartech.com