



Specialty Gas Control Panels

Specialty Gas, Terminal Gas, Generator Back-up Control Panels

Technology for a Better Future

Company Overview

Genstar Technologies Company, Inc. (GENTEC®), founded in 1969, is a global industry leader in the manufacturing of welding apparatus, pressure regulators, and gas control systems.

It is GENTEC®'s mission to provide customers with high quality, value-added products and services that surpass the strictest safety standards. All GENTEC® products are manufactured in an ISO 9001 and ISO 13485 certified facility by our experienced and dedicated workforce, using exquisite craftsmanship in conjunction with computerized automation, stringent quality control, and advanced test equipment.

Additionally, as a total system solution provider, GENTEC® offers technical support, on-site evaluation, and design/implementation. GENTEC® engineers examine all customer requirements in order to develop and recommend the best customer specific solutions.

The company takes great pride in fostering a strong relationship with each and every customer. Today, GENTEC® sells its products through a vast distribution network which extends to thousands of customers worldwide.



SPECIALTY GAS CONTROL PANEL

P3200 Series Single-Bank Specialty Gas Control Panel ----- 02-03

P3300 Series Dual-Bank Specialty Gas Control Panel ----- 04-05

P3400 Series Semi-Automatic Specialty Gas Control Panel ----- 06-07

PD3400 Series Dual-Stage Semi-Automatic Specialty Gas Control Panel ----- 08-09

P3500 Series Semi-Automatic In-Line Repair Specialty Gas Control Panel ----- 10-11

PD3500 Series Dual-stage Semi-automatic In-line Repair Specialty Gas Control Panel ----- 12-13

TERMINAL GAS CONTROL PANEL

P4000 Series Terminal Gas Control Panel ----- 14-15

P4200 Series Terminal Gas Control Panel ----- 16-17

P4400 Series Terminal Gas Control Panel ----- 18-19

P4500 Series Terminal Gas Control Panel ----- 20-21

GENERATOR BACK-UP CONTROL PANEL

BS3100 Series Generator Back-Up Control Panel ----- 22-23

ACCESSORIES

Gas Pressure Alarm System, Pressure Switches, Pressure Transducer Gauge ----- 24

Flashback Arrestors, Filters ----- 25

Pigtails, Header Bars ----- 26

Needle Valves, Relief Valves, Ball Valves, Check Valves ----- 27

Diaphragm Valves, Tube Fittings ----- 28

Cylinder Connections ----- 29

■ P3200 SERIES SINGLE-BANK SPECIALTY GAS CONTROL PANEL

P3200 Series Specialty Gas Control Panel is a single-bank control system, designed to provide accurate control of a variety of gases used in research laboratories, laser gas systems, process analyzers, etc. Vent valves can be integrated for purging to ensure maximum purity of gas and minimize contaminants. Available in both stainless steel and brass.



P3200 Series

FEATURES

- ▶ Single-bank gas supply
- ▶ 2" stainless steel pressure gauges
- ▶ All parts are mounted on a single panel for easy installation
- ▶ Inlet valve(s) for changing cylinder(s) included. Outlet and Vent valves are optional
- ▶ Diaphragm valves include an easy-to-read status window (open/close)
- ▶ Integrated safety relief valve to ensure additional safety
- ▶ Diaphragm valve connections are orbital welded to minimize contamination and leakage

Note: Stainless steel models only

SPECIFICATIONS

- ▶ Maximum inlet pressure: 4500 psi
- ▶ Maximum outlet pressure: 50/100/150/250 psi
- ▶ Operating temperature range: -40 °C to 74 °C or -40 °F to 165 °F
- ▶ Leak rate: 2×10^{-8} atm.cc/sec He
- ▶ Cv: 0.14

MATERIALS OF CONSTRUCTION

- ▶ Regulator and valve body: Brass or Stainless Steel
- ▶ Regulator seat*: PTFE, PCTFE
- ▶ Panel: Stainless Steel
- ▶ Panel inlet connections: 1/4" Genlok, 1/4" FSR, 1/2" FSR
- ▶ Panel outlet connections: 1/4" Genlok, 1/4" FSR

* In the event that the selected material of regulator seat is inappropriate for its applications, Gentec shall reserve the right to appoint an alternative seat material.

■ P3200 SERIES SINGLE-BANK SPECIALTY GAS CONTROL PANEL

DIMENSIONS

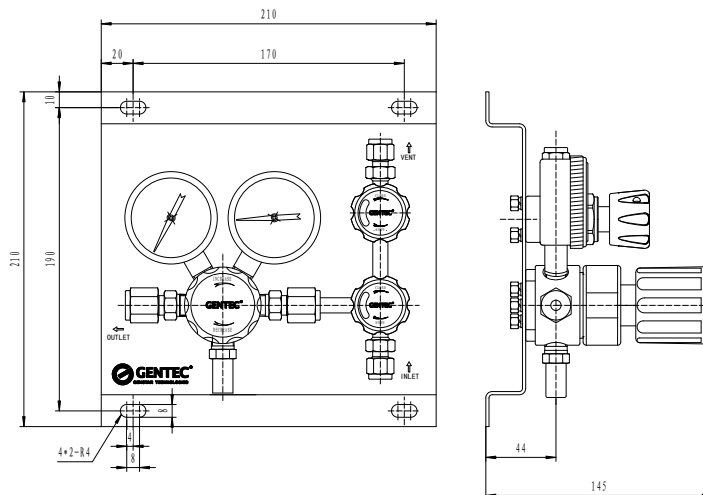

FLOW DATA

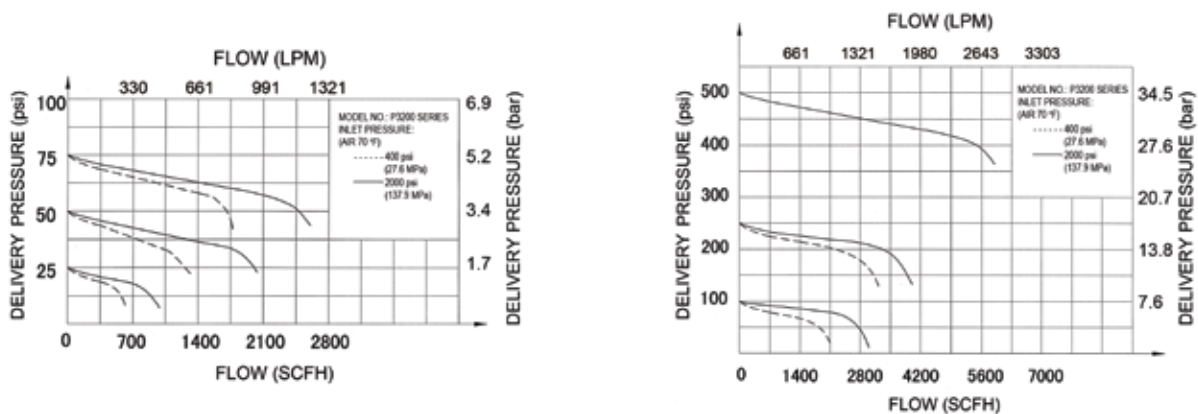

ORDERING INFORMATION

P32	1	1	S	T -	C	H	P		- N2
Series	Valve Configuration	Inlet Connections	Body	Seat	Max. Inlet Pressure	Max. Outlet Pressure	Gauge	Options	Gas Service Label
P32: Single-bank	1: Inlet/outlet/vent 2: Inlet/vent 3: Inlet/outlet 4: Inlet only	1: 1/4" Genlok (Vertical) 2: 1/4" FSR (Vertical) 3: 1/2" FSR (Straight)	S: Stainless steel B: Brass	T: PTFE K: PCTFE	C: 4500 psi D: 3000 psi F: 500 psi	L: 25 psi K: 50 psi I: 100 psi H: 150 psi G: 250 psi	P: psi / bar K: psi / kPa	Blank: Standard V: Waste gas disposal	Blank: None AIR: Air HE: Helium O ₂ : Oxygen C ₂ H ₂ : Acetylene H ₂ : Hydrogen CH ₄ : Methane CO ₂ : Carbon Dioxide Ar: Argon N ₂ : Nitrogen

■ P3300 SERIES DUAL-BANK SPECIALTY GAS CONTROL PANEL

P3300 Series Specialty Gas Control Panel is a dual-bank control system, designed to provide accurate control of a variety of gases used in research laboratories, laser gas systems, process analyzers, etc. Vent valves can be integrated for purging to ensure maximum purity of gas and minimize contaminants. A check valve located in between the inlet pressure gauge and regulator at both ends ensures additional safety for the user(s). Available in both stainless steel and brass.



P3300 Series

FEATURES

- ▶ Dual-bank gas supply
- ▶ 2" stainless steel pressure gauges
- ▶ All parts are mounted on a single panel for easy installation
- ▶ Inlet valve(s) for changing cylinder(s) included. Outlet and Vent valves are optional
- ▶ Diaphragm valves include an easy to read status window (open/close)
- ▶ Integrated safety relief valve to ensure additional safety
- ▶ Diaphragm valve connections are orbital welded to minimize contamination and leakage

Note: Stainless steel models only

SPECIFICATIONS

- ▶ Maximum inlet pressure: 4500 psi
- ▶ Maximum outlet pressure: 25/50/100/150/250 psi
- ▶ Operating temperature range: -40 °C to 74 °C or -40 °F to 165 °F
- ▶ Leak rate: 2×10^{-8} atm.cc/sec He
- ▶ Cv: 0.14

MATERIALS OF CONSTRUCTION

- ▶ Regulator and valve body: Brass or Stainless Steel
- ▶ Regulator seat*: PTFE, PCTFE
- ▶ Panel: Stainless Steel
- ▶ Panel inlet connections: 1/4" Genlok, 1/4" FSR, 1/2" FSR
- ▶ Panel outlet connections: 1/4" Genlok, 1/4" FSR

* In the event that the selected material of regulator seat is inappropriate for its applications, Gentec shall reserve the right to appoint an alternative seat material.

■ P3300 SERIES DUAL-BANK SPECIALTY GAS CONTROL PANEL

DIMENSIONS

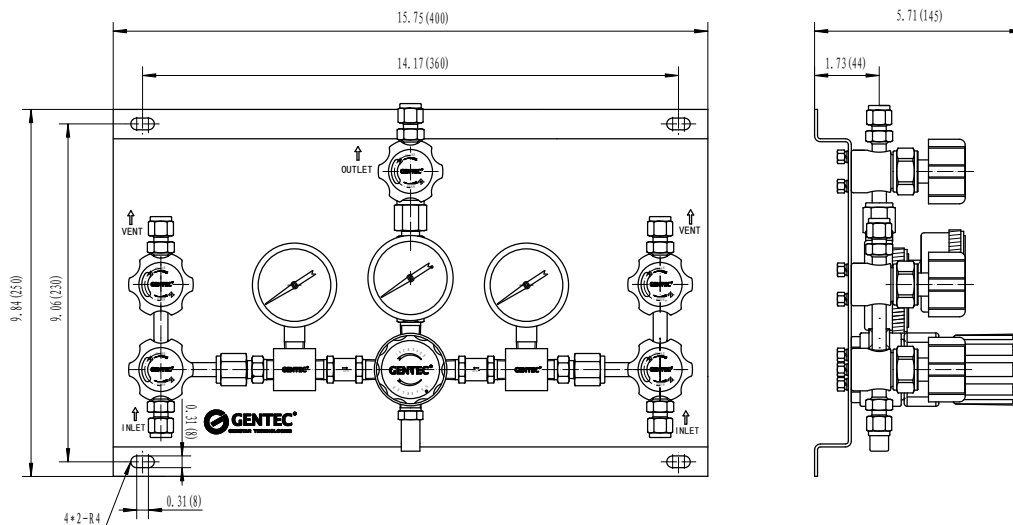

FLOW DATA

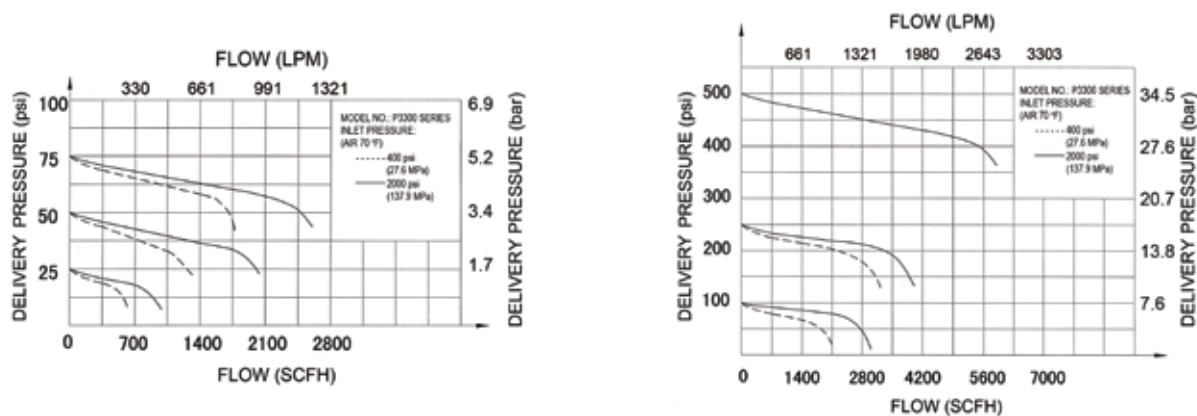

ORDERING INFORMATION

P33	1	1	S	T -	C	H	P		- N2
Series	Valve Configuration	Inlet Connections	Regulator Body	Seat	Max. Inlet Pressure	Max. Outlet Pressure	Gauge	Options	Gas Service Label
P33: Dual-bank	1: Inlet/outlet/vent 2: Inlet/vent 3: Inlet/outlet 4: Inlet only	1: 1/4" Genlok (Vertical) 2: 1/4" FSR (Vertical) 3: 1/2" FSR (Straight)	S: Stainless steel B: Brass	T: PTFE K: PCTFE	C: 4500 psi D: 3000 psi F: 500 psi	L: 25 psi K: 50 psi I: 100 psi H: 150 psi G: 250 psi	P: psi / bar K: psi / kPa	Blank: Standard V: Waste gas disposal	Blank: None AIR: Air HE: Helium O ₂ : Oxygen C ₂ H ₂ : Acetylene H ₂ : Hydrogen CH ₄ : Methane CO ₂ : Carbon Dioxide Ar: Argon N ₂ : Nitrogen

■ P3400 SERIES SEMI-AUTOMATIC SPECIALTY GAS CONTROL PANEL

P3400 Series Specialty Gas Control Panel is a dual bank semi-automatic changeover system, providing a continuous gas supply without interrupting the system during cylinder(s) replacement. When the primary bank is nearly depleted, a changeover will occur, in which the reserve bank will begin to supply gas to the system. The inlet valve on each bank provides the user additional safety while replacing the cylinder(s) on the empty bank before the next changeover occurs. Available in both stainless steel and brass.



P3400 Series

FEATURES

- ▶ Dual-bank gas supply and semi-automatic changeover
- ▶ 2" stainless steel pressure gauges
- ▶ All the components are mounted on a single panel for easy maintenance
- ▶ Inlet valve(s) for changing cylinder(s) included. Outlet and Vent valves are optional
- ▶ Diaphragm valves include an easy-read status window (open/close)
- ▶ Diaphragm valve connections are orbital welded to minimize contamination and leakage

Note: Stainless steel models only

SPECIFICATIONS

- ▶ Maximum inlet pressure: 4500 psi
- ▶ Maximum outlet pressure: 50/100/150/250 psi
- ▶ Operating temperature range: -40 °C to 74 °C or -40 °F to 165 °F
- ▶ Leak rate: 2×10^{-8} atm.cc/sec He
- ▶ Cv: 0.14

MATERIALS OF CONSTRUCTION

- ▶ Regulator and valve body: Brass or Stainless Steel
- ▶ Regulator seat*: PTFE, PCTFE
- ▶ Panel: Stainless Steel
- ▶ Panel inlet connections: 1/4" Genlok, 1/4" FSR, 1/2" FSR
- ▶ Panel outlet connections: 1/4" Genlok, 1/4" FSR

* In the event that the selected material of regulator seat is inappropriate for its applications, Gentec shall reserve the right to appoint an alternative seat material.

■ P3400 SERIES SEMI-AUTOMATIC SPECIALTY GAS CONTROL PANEL

DIMENSIONS

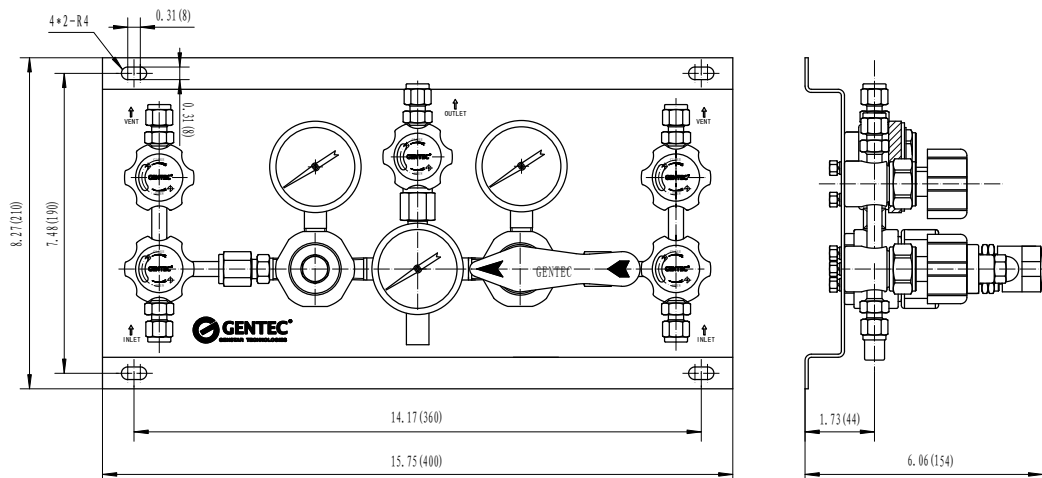

FLOW DATA

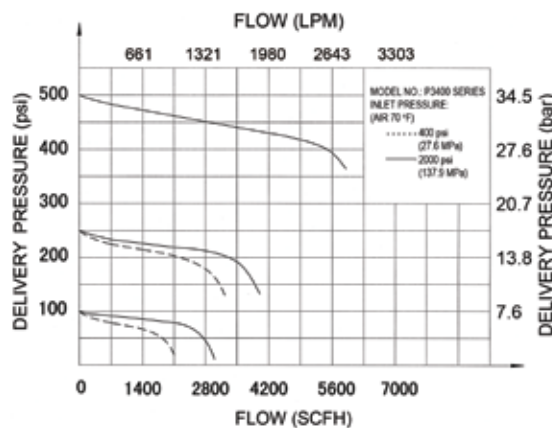
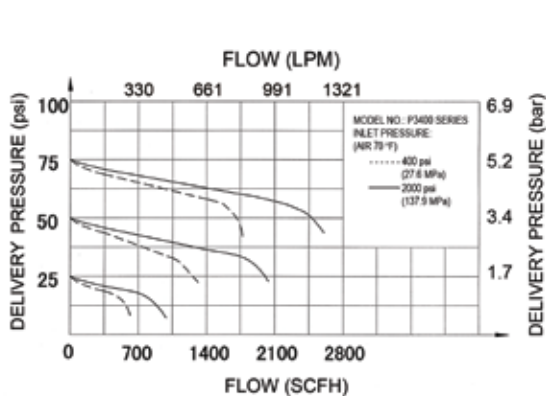

ORDERING INFORMATION

P34	1	1	S	T -	C	H	P		- N2
Series	Valve Configuration	Inlet Connections	Regulator Body	Seat	Max. Inlet Pressure	Max. Outlet Pressure	Gauge	Options	Gas Service Label
P34: Semi-automatic	1: Inlet/outlet/vent 2: Inlet/vent 3: Inlet/outlet 4: Inlet only	1: 1/4" Genlok (Vertical) 2: 1/4" FSR (Vertical) 3: 1/2" FSR (Straight)	S: Stainless steel B: Brass	T: PTFE K: PCTFE	C: 4500 psi D: 3000 psi X: 2200 psi F: 500 psi	L: 25 psi K: 50 psi I: 100 psi H: 150 psi G: 250 psi	P: psi / bar K: psi / kPa	Blank: Standard V: Waste gas disposal	Blank: None AIR: Air HE: Helium O2: Oxygen C2H2: Acetylene H2: Hydrogen CH4: Methane CO2: Carbon Dioxide Ar: Argon N2: Nitrogen

■ PD3400 SERIES DUAL-STAGE SEMI-AUTOMATIC SPECIALTY GAS CONTROL PANEL

PD3400 Series Specialty Gas Control Panel is a dual-bank dual-stage semi-automatic changeover system, providing a continuous gas supply without interrupting the system during cylinder(s) replacement. When the primary bank is nearly depleted, a changeover will occur, in which the reserve bank will begin to supply gas to the system. The inlet valve on each bank provides the user additional safety while replacing the cylinder(s) on the empty bank before the next changeover occurs. The line regulator executes a second stage pressure reduction, providing a consistent outlet pressure and flow. Available in both stainless steel and brass.



PD3400 Series

FEATURES

- ▶ Dual-bank gas supply and semi-automatic changeover
- ▶ Dual stage pressure reduction minimizes pressure and flow fluctuation
- ▶ All the components are mounted on a single panel for easy maintenance
- ▶ Inlet valve(s) for changing cylinder(s) are included. Outlet and Vent valves are optional
- ▶ Diaphragm valve connections are orbital welded to minimize contamination and leakage

Note: Stainless steel models only

SPECIFICATIONS

- ▶ Maximum inlet pressure: 4500 psi
- ▶ Maximum outlet pressure: 50/100/150/250 psi
- ▶ Operating temperature range: -40 °C to 74 °C or -40 °F to 165 °F
- ▶ Leak rate: 2×10^{-8} atm.cc/sec He
- ▶ Cv: 0.08

MATERIALS OF CONSTRUCTION

- ▶ Regulator and valve body: Brass or Stainless Steel
- ▶ Regulator seat*: PTFE, PCTFE
- ▶ Panel: Stainless Steel
- ▶ Panel inlet connections: 1/4" Genlok, 1/4" FSR, 1/2" FSR
- ▶ Panel outlet connections: 1/4" Genlok, 1/4" FSR

* In the event that the selected material of regulator seat is inappropriate for its applications, Gentec shall reserve the right to appoint an alternative seat material.

■ PD3400 SERIES DUAL-STAGE SEMI-AUTOMATIC SPECIALTY GAS CONTROL PANEL

DIMENSIONS

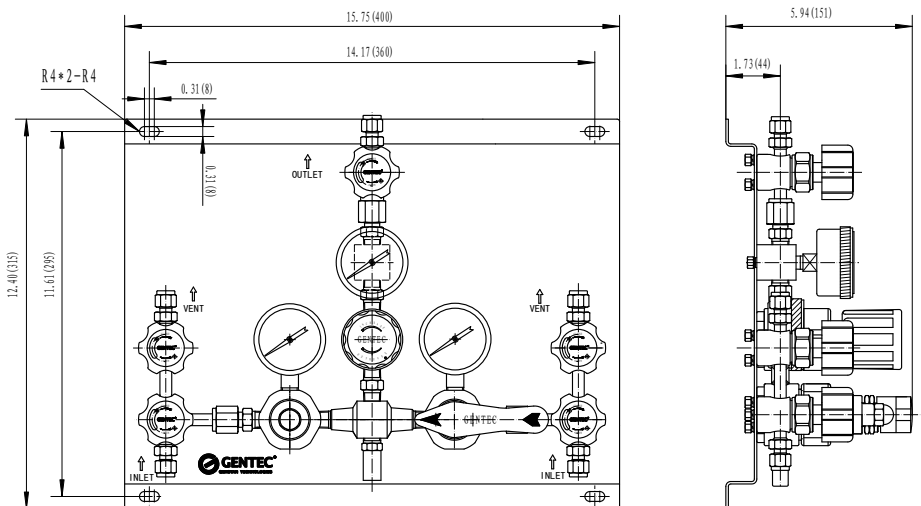

FLOW DATA

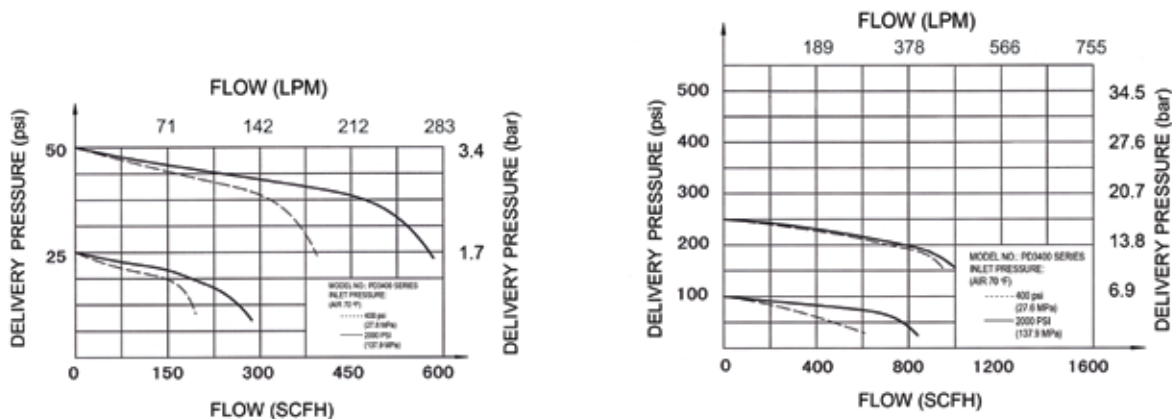

ORDERING INFORMATION

PD34	1	1	S	T -	D	H	P		- N2
Series	Valve Configuration	Inlet Connections	Body	Seat	Max. Inlet Pressure	Max. Outlet Pressure	Gauge	Options	Gas Service Label
PD34: Dual-stage Semi-automatic	1: Inlet/outlet/vent 2: Inlet/vent 3: Inlet/outlet 4: Inlet only	1: 1/4" Genlok (Vertical) 2: 1/4" FSR (Vertical) 3: 1/2" FSR (Straight)	S: Stainless steel B: Brass	T: PTFE K: PCTFE	C: 4500 psi D: 3000 psi X: 2200 psi F: 500 psi	L: 25 psi K: 50 psi I: 100 psi H: 150 psi G: 250 psi	P: psi / bar K: psi / kPa	Blank: Standard V: Waste gas disposal	Blank: None AIR: Air HE: Helium O2: Oxygen C2H2: Acetylene H2: Hydrogen CH4: Methane CO2: Carbon Dioxide Ar: Argon N2: Nitrogen

■ P3500 SERIES SEMI-AUTOMATIC IN-LINE REPAIR SPECIALTY GAS CONTROL PANEL

P3500 Series Specialty Gas Control Panel is a dual-bank semi-automatic changeover system, providing a continuous gas supply without interrupting the system during cylinder(s) replacement. When the primary bank is nearly depleted, a changeover will occur, in which the reserve bank will begin to supply gas to the system. One isolation valve on each bank allows the user to replace the cylinder(s) without discontinuing the gas supply. Each regulator is mounted on individual panels for convenient in-line repair. Available in both stainless steel and brass.



P3500 Series

FEATURES

- ▶ Dual-bank gas supply and semi-automatic changeover
- ▶ 2" stainless steel pressure gauges
- ▶ Isolation valves shut off single bank gas supply for safe maintenance
- ▶ Inlet valve(s) for changing cylinder(s) included. Outlet and Vent valves are optional
- ▶ Diaphragm valves include an easy-read status window (open/close)
- ▶ Diaphragm valve connections are orbital welded to minimize contamination and leakage

Note: Stainless steel models only

SPECIFICATIONS

- ▶ Maximum inlet pressure: 4500 psi
- ▶ Maximum outlet pressure: 25/50/100/150/250 psi
- ▶ Operating temperature range: -40 °C to 74 °C or -40 °F to 165 °F
- ▶ Leak rate: 2×10^{-8} atm.cc/sec He
- ▶ Cv: 0.14

MATERIALS OF CONSTRUCTION

- ▶ Regulator and valve body: Brass or Stainless Steel
- ▶ Regulator seat*: PTFE, PCTFE
- ▶ Panel: Stainless Steel
- ▶ Panel inlet connections: 1/4" Genlok, 1/4" FSR, 1/2" FSR
- ▶ Panel outlet connections: 1/4" Genlok, 1/4" FSR

* In the event that the selected material of regulator seat is inappropriate for its applications, Gentec shall reserve the right to appoint an alternative seat material.

■ P3500 SERIES SEMI-AUTOMATIC IN-LINE REPAIR SPECIALTY GAS CONTROL PANEL

DIMENSIONS

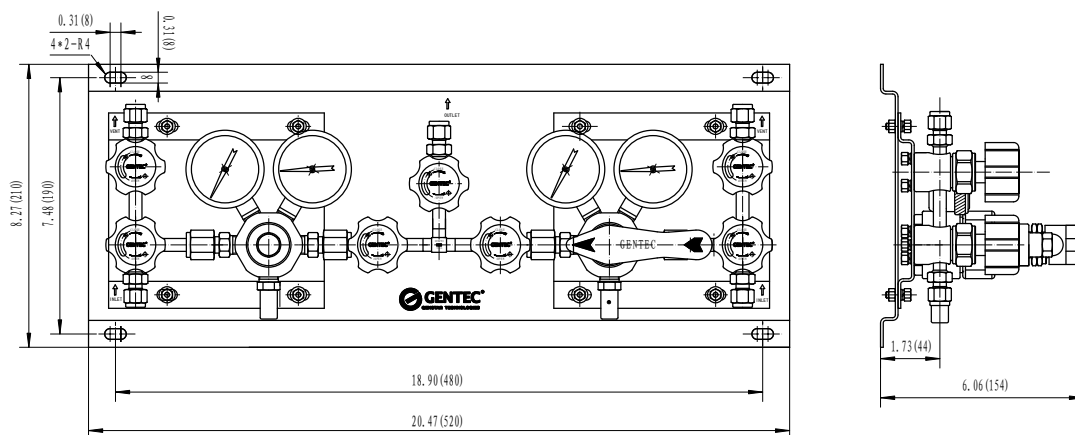

FLOW DATA

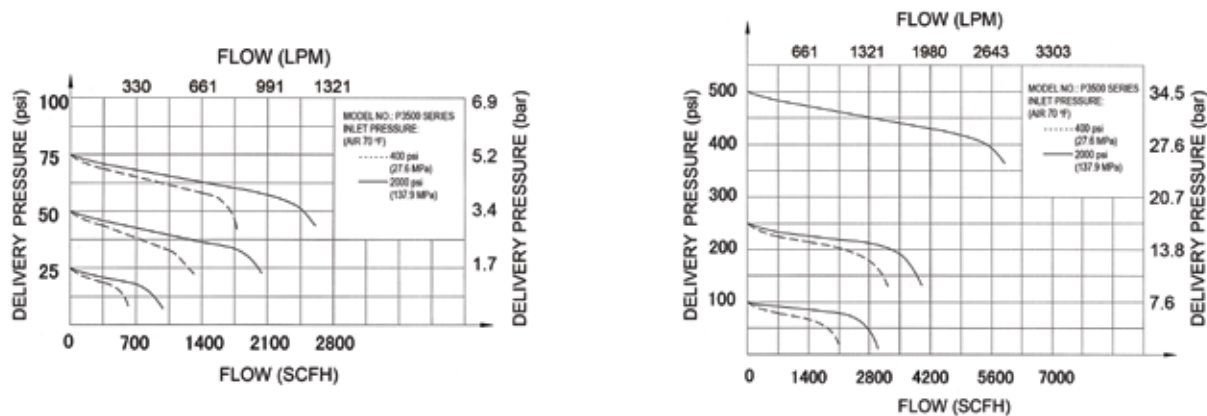

ORDERING INFORMATION

P35	1	1	S	T -	D	H	P		- N2
Series	Valve Configuration	Inlet Connections	Body	Seat	Max. Inlet Pressure	Max. Outlet Pressure	Gauge	Options	Gas Service Label
P35: Semi-automatic In-line repair	1: Inlet/outlet/vent 2: Inlet/vent 3: Inlet/outlet 4: Inlet only	1: 1/4" Genlok (Vertical) 2: 1/4" FSR (Vertical) 3: 1/2" FSR (Straight)	S: Stainless Steel B: Brass	T: PTFE K: PCTFE	C: 4500 psi D: 3000 psi X: 2200 psi F: 500 psi	L: 25 psi K: 50 psi I: 100 psi H: 150 psi G: 250 psi	P: psi / bar K: psi / kPa	Blank: Standard V: Waste gas disposal	Blank: None AIR: Air HE: Helium O2: Oxygen C2H2: Acetylene H2: Hydrogen CH4: Methane CO2: Carbon Dioxide Ar: Argon N2: Nitrogen

■ PD3500 SERIES DUAL-STAGE SEMI-AUTOMATIC IN-LINE REPAIR SPECIALTY GAS CONTROL PANEL

PD3500 Series Specialty Gas Control Panel is a dual-bank dual-stage semi-automatic in-line repair changeover system, providing a continuous gas supply without interrupting the system during cylinder(s) replacement. When the primary bank is nearly depleted, the reserve bank will begin to supply gas to the system. In addition, an isolation valve on each bank allows the user to replace the cylinder(s) and maintain bank regulator without discontinuing the gas supply. Each regulator is mounted on individual panels for convenient in-line repair. The line regulator executes a second-stage pressure reduction, providing a consistent outlet pressure and flow. Available in both stainless steel and brass.



PD3500 Series

FEATURES

- ▶ Dual-bank gas supply and semi-automatic changeover
- ▶ Dual stage pressure reduction minimizes pressure and flow fluctuation
- ▶ Isolation valves shut off single bank gas supply for safe maintenance
- ▶ Individual panels allow in-line repair of regulator
- ▶ Inlet valve(s) for changing cylinder(s) included. Outlet and Vent valves are optional
- ▶ Diaphragm valve connections are orbital welded to minimize contamination and leakage.

Note: Stainless steel models only

SPECIFICATIONS

- ▶ Maximum inlet pressure: 4500 psi
- ▶ Maximum outlet pressure: 25/50/100/150/250 psi
- ▶ Operating temperature range: -40 °C to 74 °C or -40 °F to 165 °F
- ▶ Leak rate: 2×10^{-8} atm.cc/sec He
- ▶ Cv: 0.08

MATERIALS OF CONSTRUCTION

- ▶ Regulator and valve body: Brass or Stainless Steel
- ▶ Regulator seat*: PTFE, PCTFE
- ▶ Panel: Stainless Steel
- ▶ Panel inlet connections: 1/4" Genlok, 1/4" FSR, 1/2" FSR
- ▶ Panel outlet connections: 1/4" Genlok, 1/4" FSR

* In the event that the selected material of regulator seat is inappropriate for its applications, Gentec shall reserve the right to appoint an alternative seat material.

■ PD3500 SERIES DUAL-STAGE SEMI-AUTOMATIC IN-LINE REPAIR SPECIALTY GAS CONTROL PANEL

DIMENSIONS

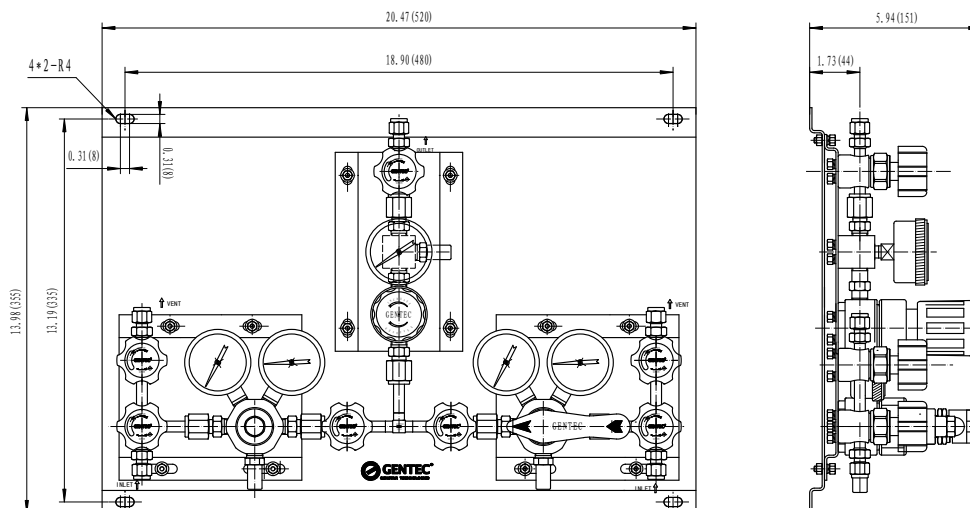

FLOW DATA

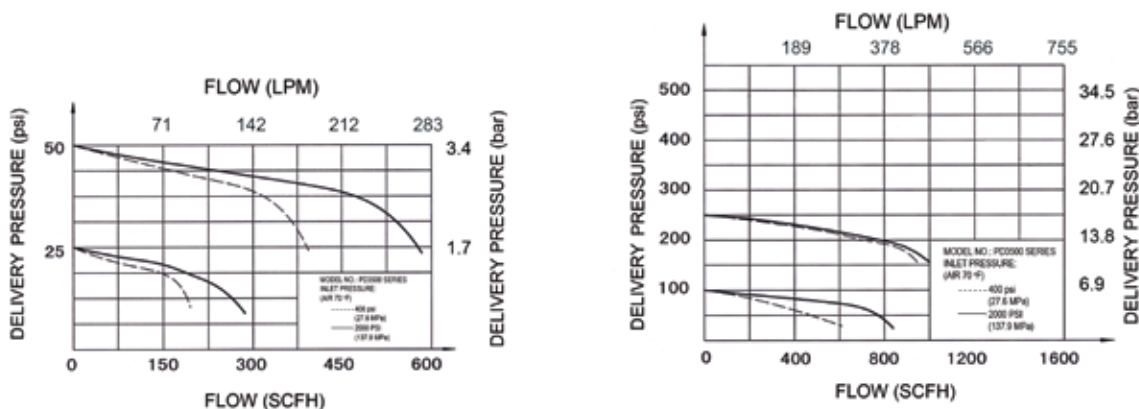

ORDERING INFORMATION

PD35	1	1	S	T -	D	H	P		- N2
Series	Valve Configuration	Inlet Connections	Body	Seat	Max. Inlet Pressure	Max. Outlet Pressure	Gauge	Options	Gas Service Label
PD35: Dual-stage Semi-automatic In-line repair	1: Inlet/outlet/vent 2: Inlet/vent 3: Inlet/outlet 4: Inlet only	1: 1/4" Genlok (Vertical) 2: 1/4" FSR (Vertical) 3: 1/2" FSR (Straight)	S: Stainless steel B: Brass	T: PTFE K: PCTFE	C: 4500 psi D: 3000 psi X: 2200 psi F: 500 psi	L: 25 psi K: 50 psi I: 100 psi H: 150 psi G: 250 psi	P: psi / bar K: psi / kPa	Blank: Standard V: Waste gas disposal	Blank: None AIR: Air HE: Helium O2: Oxygen C2H2: Acetylene H2: Hydrogen CH4: Methane CO2: Carbon Dioxide Ar: Argon N2: Nitrogen

■ P4000 SERIES TERMINAL GAS CONTROL PANEL

P4000 Series Terminal Gas Control Panel is designed for accurate control of high purity gases in downstream applications where pressure regulation is not required. The P4000 Series come in a variety of configurations ranging from one outlet point to multiple outlet points, as well as one terminal to multiple terminals to meet a wide range of requirements and applications. Please see ordering information for more options.



P4011SL-GP-B12B12



P4021SL-GP-B12B12



P4031SL-GP-B12B12

FEATURES

- ▶ Designed for terminal gas control
- ▶ Easy-to-read 2" stainless steel pressure gauges
- ▶ Single panel configuration for easy installation
- ▶ Valves are available in three types: ball valves, diaphragm valves, and needle valves

SPECIFICATIONS

- ▶ Operating temperature range: -40°C to 74°C or -40°F to 165°F
- ▶ Leak rate: 2×10^{-8} atm.cc/sec He

MATERIALS OF CONSTRUCTION

- ▶ Valve body: Stainless Steel
- ▶ Pressure gauge: Stainless Steel

P4000 SERIES TERMINAL GAS CONTROL PANEL

DIMENSIONS

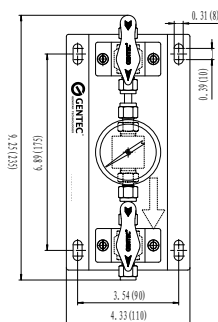

P4011

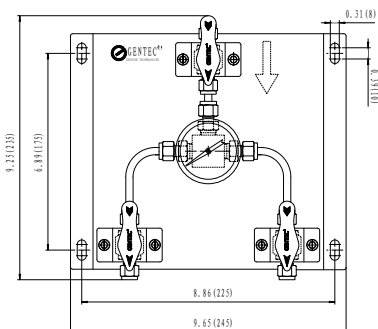

P4021

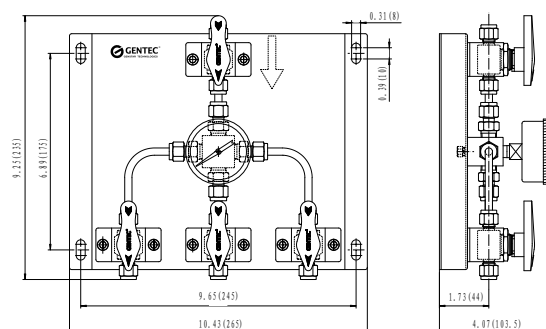

P4031

ORDERING INFORMATION

P40	2	1	SL -	H	P	C -	B	12	W	12 -	AIR
Series	Inlet / Outlet Connection	No. of Terminals	Material	Max. Pressure	Gauge	Option	Inlet Valves	Inlet Connection Type	Outlet Valves	Outlet Connection Type	Gas Service Label
P40	1: One inlet / one outlet 2: One inlet / two outlets 3: One inlet / three outlets	1: One 2: Two 3: Three	SL: Stainless steel	L: 25 psi K: 50 psi I: 100 psi H: 150 psi G: 250 psi	P: psi / bar K: psi / kPa	Blank: Standard C: Pressure transducer gauge	B: Ball D: Diaphragm N: Needle W: None	11: 1/8" Genlok 12: 1/4" Genlok 22: 6 mm Genlok 23: 8 mm Genlok 31: 1/8" NPT (F) 32: 1/4" NPT (F) 61: 1/4" FSR (M) More connections available upon request	B: Ball D: Diaphragm N: Needle W: None	11: 1/8" Genlok 12: 1/4" Genlok 22: 6mm Genlok 23: 8mm Genlok 31: 1/8" NPT (F) 32: 1/4" NPT (F) 61: 1/4" FSR (M) More connections available upon request	Blank: None AIR: Air HE: Helium O2: Oxygen C2H2: Acetylene H2: Hydrogen CH4: Methane CO2: Carbon Dioxide Ar: Argon N2: Nitrogen

■ P4200 SERIES TERMINAL GAS CONTROL PANEL

P4200 Series Terminal Gas Control Panel is designed for accurate control of gases in downstream applications such as laboratory gas distributions, assembly lines, etc. This series of control panels come in a variety of configurations, ranging from one outlet point to multiple outlet points, as well as one terminal to multiple terminals to meet a wide range of requirements and applications. Please see ordering information for more options.



P4211SL-GP-B12B12



P4221SL-GP-B12B12



P4231SL-GP-B12B12

FEATURES

- ▶ Designed for “Research Grade” terminal gas control
- ▶ Terminal gas regulation to provide end-users consistent pressure and flow
- ▶ Easy-to-read 2” stainless steel pressure gauges
- ▶ Single panel configuration for easy installation
- ▶ Valves are available in three types: ball valves, diaphragm valves, and needle valves

SPECIFICATIONS

- ▶ Maximum outlet pressure: 50/100/150/250 psi
- ▶ Operating temperature range: -40°C to 74°C or -40°F to 165°F
- ▶ Leak rate: 2×10^{-8} atm.cc/sec He
- ▶ Cv: 0.14

MATERIALS OF CONSTRUCTION

- ▶ Regulator body, diaphragm, filter: Stainless Steel
- ▶ Regulator seat: PCTFE
- ▶ Valve body: Stainless Steel
- ▶ Pressure gauge: Stainless Steel

P4200 SERIES TERMINAL GAS CONTROL PANEL

DIMENSIONS

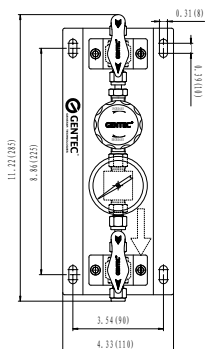

P4211

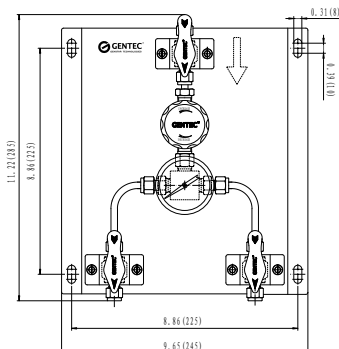

P4221

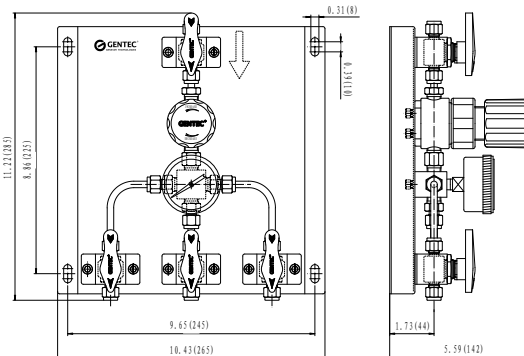

P4231

FLOW DATA

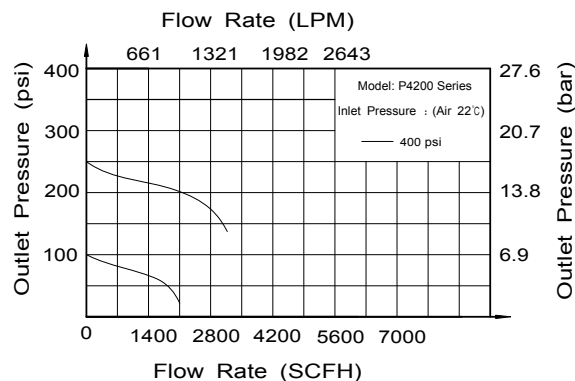
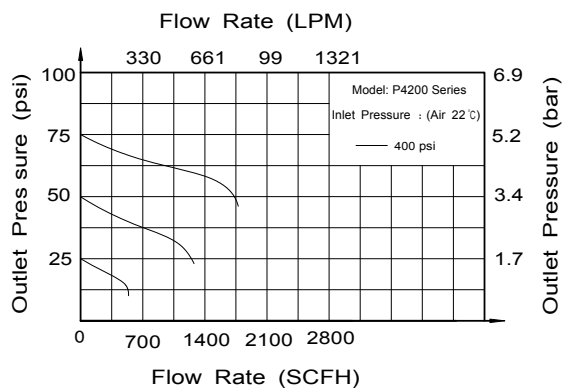

ORDERING INFORMATION

P42 Series	2 Inlet / Outlet Connection	1 No. of Terminals	SL - Material	H Max. Pressure	P Gauge	C - Option	B Inlet Valves	12 Inlet Connection Type	W Outlet Valves	12 - Outlet Connection Type	AIR Gas Service Label
P42	1: One inlet / one outlet 2: One inlet / two outlets 3: One inlet / three outlets	1: One 2: Two 3: Three	SL: Stainless steel	L: 25 psi K: 50 psi I: 100 psi H: 150 psi G: 250 psi	P: psi / bar K: psi / kPa	Blank: Standard C: Pressure transducer gauge	B: Ball D: Diaphragm N: Needle W: None	11: 1/8" Genlok 12: 1/4" Genlok 22: 6 mm Genlok 23: 8 mm Genlok 31: 1/8" NPT (F) 32: 1/4" NPT (F) 61: 1/4" FSR (M) More connections available upon request	B: Ball D: Diaphragm N: Needle W: None	11: 1/8" Genlok 12: 1/4" Genlok 22: 6mm Genlok 23: 8mm Genlok 31: 1/8" NPT (F) 32: 1/4" NPT (F) 61: 1/4" FSR (M) More connections available upon request	Blank: None AIR: Air HE: Helium O2: Oxygen C2H2: Acetylene H2: Hydrogen CH4: Methane CO2: Carbon Dioxide Ar: Argon N2: Nitrogen

■ P4400 SERIES TERMINAL GAS CONTROL PANEL

P4400 Series Terminal Gas Control Panel is designed for accurate control of industrial gases in low flow applications. Regulator, pressure gauge, and ball valve have been forged as one body to minimize the possibility of leaks. This series of control panel comes in one or multiple terminals to meet a wide range of requirements and applications. Please see ordering information for more options.



P4411B-HK-B81W81



P4412B-HK-B81W81



P4413B-HK-B81W81

FEATURES

- ▶ Designed for downstream control
- ▶ Easy-to-read 2" stainless steel pressure gauges
- ▶ Uses BLK 101 Regulator
- ▶ Single body minimizes point of leaks and contamination
- ▶ Adjustable outlet pressure
- ▶ Single panel configuration for easy installation

SPECIFICATIONS

- ▶ Maximum outlet pressure: 50/100/150/250 psi
- ▶ Operating temperature range: -40°C to 74°C or -40°F to 165°F
- ▶ Leak rate: 2×10^{-8} atm.cc/sec He
- ▶ Cv: 0.14

MATERIALS OF CONSTRUCTION

- ▶ Regulator body: Chrome-plated brass
- ▶ Inlet and outlet connection: 1/4" SAE (F)
- ▶ Ball valve body: Stainless Steel
- ▶ Pressure gauge: Stainless Steel

P4400 SERIES TERMINAL GAS CONTROL PANEL

DIMENSIONS

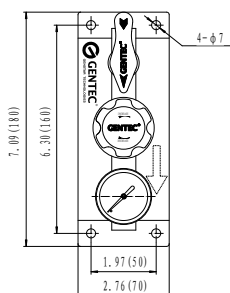

P4411

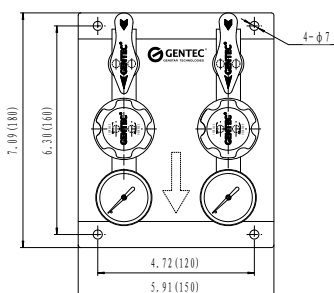

P4421

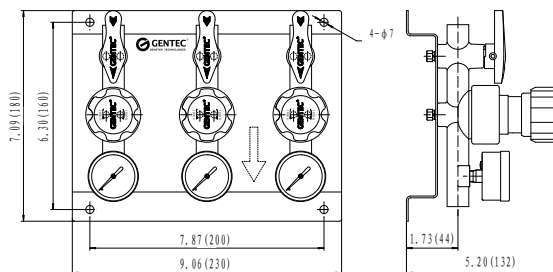

P4431

FLOW DATA

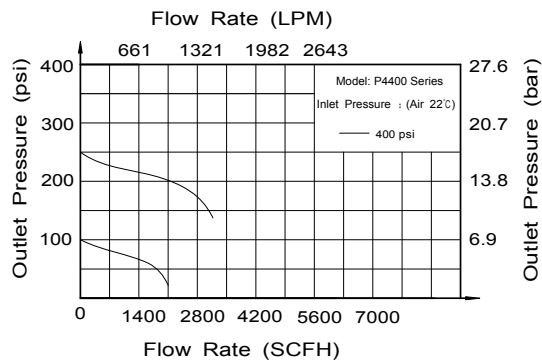
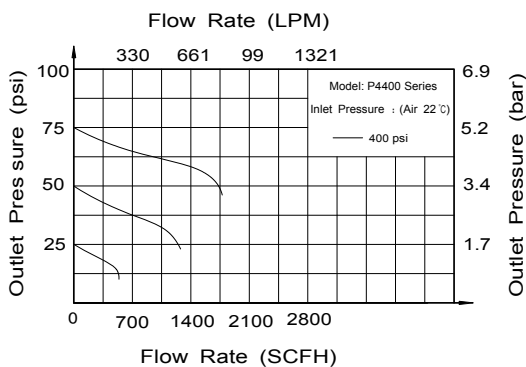

ORDERING INFORMATION

P44	2	1	B -	H	P	C -	B	31	W	31 -	AIR
Series	Inlet / Outlet Connection	No. of Terminals	Material	Max. Pressure	Gauge	Option	Inlet Valves	Inlet Connection Type	Outlet Valves	Outlet Connection Type	Gas Service Label
P44	1: One inlet / one outlet 2: One inlet / two outlets 3: One inlet / three outlets	1: One 2: Two 3: Three	B: Chrome-plated brass	L: 25 psi K: 50 psi I: 100 psi H: 150 psi G: 250 psi	P: psi / bar K: psi / kPa	Blank: Standard C: Pressure transducer gauge	B: Ball W: None	31: 1/8" NPT (F) 81: 1/4" SAE (F) More connections available upon request	W: None	31: 1/8" NPT (F) 81: 1/4" SAE (F) More connections available upon request	Blank: None AIR: Air HE: Helium O2: Oxygen C2H2: Acetylene H2: Hydrogen CH4: Methane CO2: Carbon Dioxide Ar: Argon N2: Nitrogen

■ P4500 SERIES TERMINAL GAS CONTROL PANEL

P4500 Series Terminal Gas Control Panel is designed for accurate control of industrial gases in medium flow applications. Regulator, pressure gauge, and ball valve have been forged as one body to minimize the possibility of leaks. This series of control panel comes in one or multiple terminals to meet a wide range of requirements and applications. Please see ordering information for more options.



P4511B-HK-B83W83



P4521B-HK-B83W83



P4531B-HK-B83W83

FEATURES

- ▶ Designed for terminal gas control
- ▶ Easy-to-read 2" stainless steel pressure gauges
- ▶ Uses BLK 102 Regulator
- ▶ Single body minimizes point of leaks and contamination
- ▶ Adjustable outlet pressure
- ▶ Single panel configuration for easy installation

SPECIFICATIONS

- ▶ Maximum outlet pressure: 50/100/150/250 psi
- ▶ Operating temperature range: -40°C to 74°C or -40°F to 165°F
- ▶ Leak rate: 2×10^{-8} atm.cc/sec He
- ▶ Cv: 1.1

MATERIALS OF CONSTRUCTION

- ▶ Regulator body: Chrome-plated brass
- ▶ Regulator seat: PCTFE
- ▶ Inlet and outlet connection: 1/2" SAE (F)
- ▶ Ball valve body: Stainless Steel
- ▶ Pressure gauge: Stainless Steel

P4500 SERIES TERMINAL GAS CONTROL PANEL

DIMENSIONS

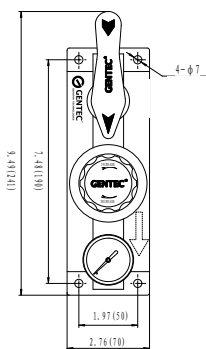

P4511

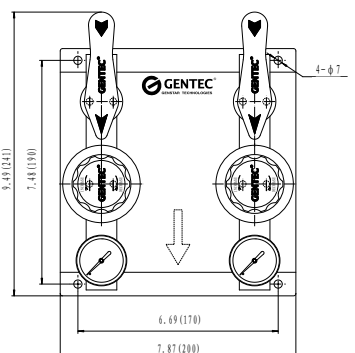

P4521

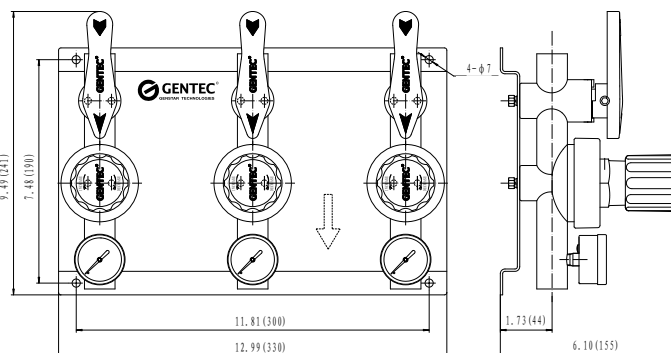

P4531

FLOW DATA

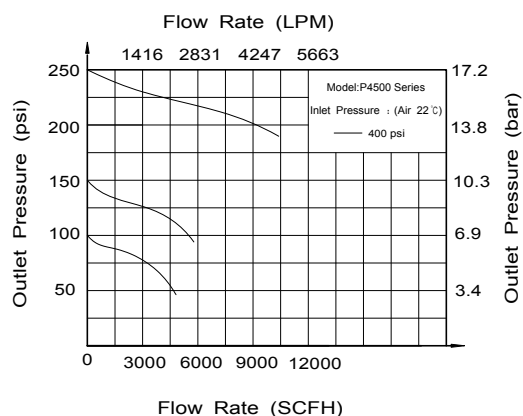
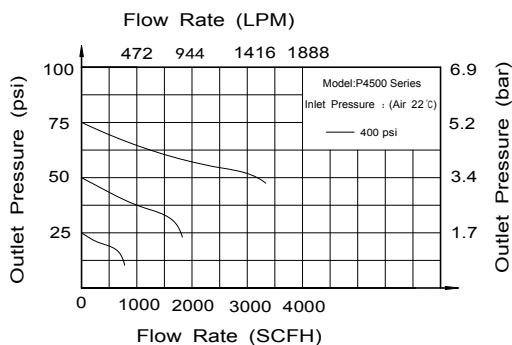

ORDERING INFORMATION

P45	2	1	B -	H	P	C -	B	33	W	33 -	AIR
Series	Inlet / Outlet Connection	No. of Terminals	Material	Max. Pressure	Gauge	Option	Inlet Valves	Inlet Connection Type	Outlet Valves	Outlet Connection Type	Gas Service Label
P45	1: One inlet / one outlet 2: One inlet / two outlets 3: One inlet / three outlets	1: One 2: Two 3: Three	B: Chrome-plated brass	L: 25 psi K: 50 psi I: 100 psi H: 150 psi G: 250 psi	P: psi / bar K: psi / kPa	Blank: Standard C: Pressure transducer gauge	B: Ball W: None	33: 3/8" NPT (F) 83: 1/2" SAE (F) More connections available upon request	W: None	33: 3/8" NPT (F) 83: 1/2" SAE (F) More connections available upon request	Blank: None AIR: Air HE: Helium O2: Oxygen C2H2: Acetylene H2: Hydrogen CH4: Methane CO2: Carbon Dioxide Ar: Argon N2: Nitrogen

■ BS3100 SERIES GENERATOR BACK-UP CONTROL PANEL

BS3100 Series Generator Back-up Control Panel is a hybrid control system, with the gas generator as the primary source of gas supply and the cylinder as the reserve. The automatic changeover provides a continuous gas supply without interrupting the system during generator maintenance. When the pressure of the generator drops below a preset value, the cylinder will begin to supply gas to the system. The line regulator executes a second stage pressure reduction, providing a consistent outlet pressure and flow. This series is available in both stainless steel and brass.



BS3100SL-45-DKP-00

FEATURES

- ▶ Hybrid dual-bank gas supply and automatic changeover
- ▶ Dual-stage pressure reduction to minimizes pressure and flow fluctuation
- ▶ Inlet valves allow the user to isolate either source of gas supply for maintenance
- ▶ The integrated check valve ensures system safety

SPECIFICATIONS

- ▶ Maximum Generator Inlet Pressure: 380 psi
- ▶ Maximum Cylinder Inlet Pressure: 3000 psi
- ▶ Outlet Pressure Range: 0-45 psi
- ▶ Maximum Flow: 60 SLPM
- ▶ Operating Temperature Range: -40°C to 74°C or -40°F to 165°F
- ▶ Leak Rate: 2 x 10⁻⁸ atm.cc/sec He
- ▶ Changeover Pressure: as selected by customer(s)

MATERIALS OF CONSTRUCTION

- ▶ Regulator body: Brass or Stainless Steel
- ▶ Regulator inlet/outlet port: ¼" NPT (F)
- ▶ Cylinder inlet connection: CGA
- ▶ Inlet valve body: Stainless Steel
- ▶ Check valve body: Stainless Steel

■ BS3100 SERIES GENERATOR BACK-UP CONTROL PANEL

DIMENSIONS

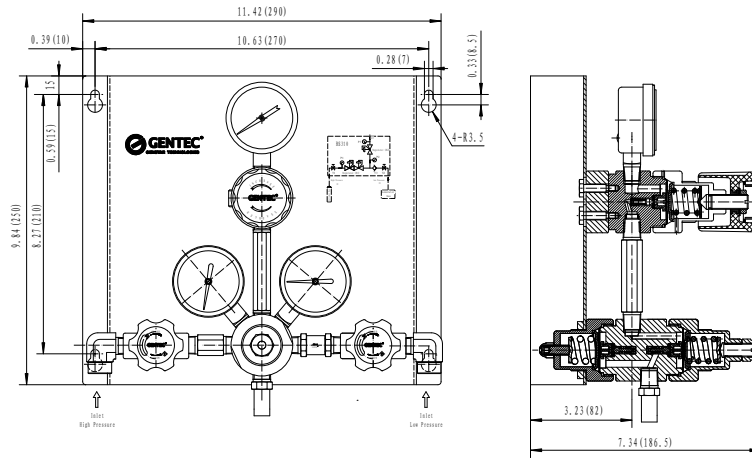

FLOW DATA

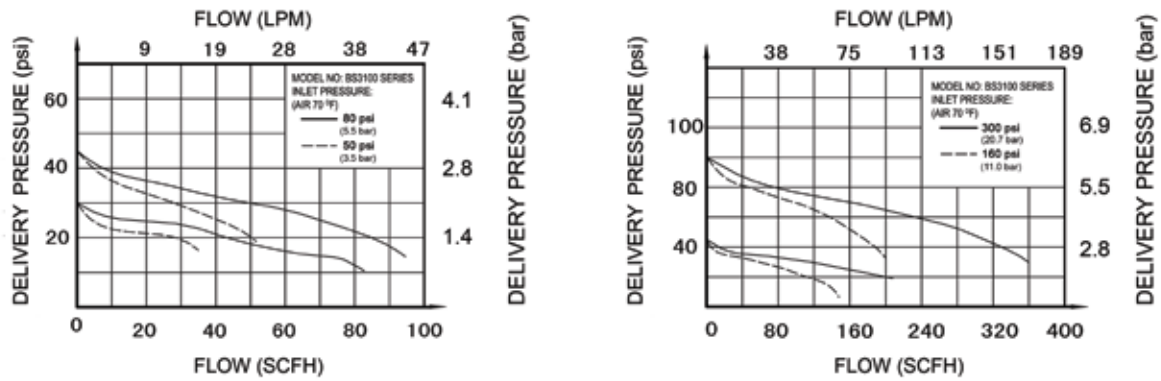

ORDERING INFORMATION

BS31	0	0	SL -	45	D	K	P	23 -	AIR
Series	Primary Supply Max. Pressure	Inlet/Outlet Connection	Material	Max. Outlet Pressure	Backup Cylinders Pressure	Preset Pressure	Gauge	Backup Cylinder Inlet Connection	Gas Service Label
BS3100	0: 85 psi 1: 180 psi 3: 380 psi	0: No vent valves 1: Vent valves	SL: Stainless steel B: Brass	45: 45 psi	D: 3000 psi X: 2200 psi F: 500 psi	K: 50 psi I: 100 psi H: 150 psi	P: psi / bar K: psi / kPa	00: 1/4" NPT (F) 23: CGA 330 24: CGA 350 25: CGA 510 26: CGA 540 27: CGA 580 More connections available upon request	Blank: None AIR: Air HE: Helium O ₂ : Oxygen C ₂ H ₂ : Acetylene H ₂ : Hydrogen CH ₄ : Methane CO ₂ : Carbon Dioxide Ar: Argon N ₂ : Nitrogen

ACCESSORIES

GAS PRESSURE ALARM SYSTEM

- ▶ Connect with pressure gauge & pressure switch for monitoring of gas(es)
- ▶ LED display 1 to 4 gas status
- ▶ Sound alarm
- ▶ Mute button
- ▶ Connection for distance alarm
- ▶ Voltage: 110VAC/ 220VAC

*For explosion-proof model, add "S" to the model number



SGPA-1-220 *
Monitors 1 Gas



SGPA-2-220 *
Monitors 2 Gases



SGPA-4-220 *
Monitors 4 Gases

PRESSURE SWITCHES

- ▶ Complements gas alarm systems
- ▶ Monitors gas pressure
- ▶ Designed to provide signal to alarm systems
- ▶ Pressure is adjustable



Anti-explosion Model



Standard Model

Model Number	Pressure Range	Max. Inlet Pressure	Connection	Anti-Explosion
GHPS-1	4~50 psi	1000 psi	1/8" NPT(M)	NO
GHPS-2	300~600 psi	2500 psi	1/8" NPT(M)	NO
GHPS-3	100~1500 psi	8000 psi	1/4" NPT(M)	NO
GHPS-4E	2~25 psi	600 psi	1/4" NPT(F)	YES
GHPS-5E	15~75 psi	600 psi	1/4" NPT(F)	YES
GHPS-6E	50~450 psi	2000 psi	1/4" NPT(F)	YES

PRESSURE TRANSDUCER GAUGE

- ▶ Monitors gas pressure
- ▶ Designed to provide signal to alarm systems
- ▶ Range: 0-3000 psi
- ▶ Connection: 1/4" NPT
- ▶ Rear entry



GRE20-3000

ACCESSORIES

GENERAL PURPOSE FLASHBACK ARRESTORS

- ▶ Designed for use with low pressure manifold piping, preventing flashbacks from low to high pressure piping



FA30PO



FA30PO



FA31PH



FA33SP

Model Number	Gas Service	Working Pressure	Delivery Flow	Inlet Connection	Outlet Connection	Material
FA30PF	Acetylene	22 psi	2500 SCFH	3/4" NPT(F)	3/4" NPT(F)	Brass
FA30PO	Oxygen	145 psi	5825 SCFH	3/4" NPT(F)	3/4" NPT(F)	Brass
FA31PH	Hydrogen	50 psi	2120 SCFH	1/4" NPT(F)	1/4" NPT(F)	Brass
FA33SP	LPG	70 psi	820 SCFH	1/4" NPT(F)	1/4" NPT(F)	Stainless steel
	Hydrogen	50 psi	720 SCFH	1/4" NPT(F)	1/4" NPT(F)	Stainless steel
	Acetylene	22 psi	300 SCFH	1/4" NPT(F)	1/4" NPT(F)	Stainless steel

FILTERS*

- ▶ Material: 316
- ▶ Maximum working pressure: 3000 psi for inline type, 6000 psi for T-type
- ▶ Washer: 316L
- ▶ Nominal pore size: 0.5, 2, 7, 15, 60, 90

Type	Series	Inlet Connection	Outlet Connection
Inline type	SS-F4-TF4	1/4" GENLOK	1/4" GENLOK
	SS-F4-FNT2	1/8" NPT(F)	1/8" NPT(F)
	SS-F4-NT4	1/4" NPT(M)	1/4" NPT(M)
T-type	SS-F4T-TF4	1/4" GENLOK	1/4" GENLOK
	SS-F4T-FNT4	1/8" NPT(F)	1/8" NPT(F)
	SS-F4T-NT4	1/4" NPT(M)	1/4" NPT(M)



Inline Filters



T-type Filters

* Please see "F Series Filters" catalog for more information

ACCESSORIES

PIGTAILS

- ▶ Stainless steel pigtails are designed to be used between cylinder and piping system, available in flexible and rigid types.



Flexible Pigtails



Rigid Pigtails

Series	Length -	Inlet Connection	Options -	Outlet Connection	Series	Inlet Connection -	Outlet Connection
GFPT (Stainless steel flexible pigtail with Teflon insert)	24: 24" 36: 36"	00: 1/4" NPT(F) G5/8: G5/8" G5/8LH: G5/8"LH 320: CGA320 350: CGA350 540: CGA540 Oxygen 580: CGA580	Blank: None CV: with Check Valve FA: with Flash back Arrestor	00: 1/4" NPT(F)	GRPS (Stainless steel rigid pigtail)	00: 1/4" NPT(F) G5/8: G5/8" G5/8LH: G5/8"LH 320: CGA320 350: CGA350 540: CGA540 Oxygen 580: CGA580	VF4: 1/4" Female FSR OD4: 1/4" Tube
GFPS (Stainless steel flexible pigtail with stainless steel insert)		BS2: BS341 NO 2 BS4: BS341 NO 4 DIN3: DIN477 NO 3 DIN9: DIN477 NO 9 More connections available upon request				BS2: BS341 NO 2 BS4: BS341 NO 4 DIN3: DIN477 NO 3 DIN9: DIN477 NO 9 More connections available upon request	

HEADER BARS

- ▶ Modular design for easy installation and future expansion
- ▶ Outlet connections are available in both Genlok tube fitting and FSR fittings
- ▶ Maximum inlet pressure of 3000 psi
- ▶ 100% tested to ensure there are no leaks



GSML-210D-FNT4-TF8-5



GSML-210D-FNT4-VSF8-12

GSM	R -	2	10	D -	FNT4 -	VSF8 -	12
Series	Configuration	Stations	Station Spacing	Valve Configuration	Inlet Connection	Outlet Connection	Spacer
GSM: Stainless steel	R: Right L: Left	2/3/5	05: 5" 10*: 10" 13: 13"	W: None N: Needle valve D: Diaphragm valve*	FNT4*: 1/4"NPT(F) NT4: 1/4"NPT(M) VM4: 1/4"FSR(M)	VSF8*: 1/2"FSR(F) Orbital welded TF8: 1/2"GENLOK Tube Fittings	Blank*: 5" 12: 12"

■ ACCESSORIES

NEEDLE VALVES*

Series	Material	Max. Working Pressure	Inlet/ Outlet Connection
207CP	Chrome-plated brass	500 psi	1/4" NPT(M) x 1/4" NPT(M)
SS-NV12-NT4	316	5000 psi	1/4" NPT(M) x 1/4" NPT(M)
SS-NV12-NT4-TF4	316	5000 psi	1/4" NPT(M) x 1/4" GENLOK



207CP



SS-NV12-NT4-TF4

RELIEF VALVES*

- ▶ Designed for use with regulators
- ▶ Relief pressure adjustable
- ▶ Inlet connection: 1/4" NPT
- ▶ Outlet connection: G1/4" (F)

Material	Series	-	Pressure Range
SS: 316	RV11		20: 10-20 psi
B: Chrome-plated brass			100: 20-100 psi
			250: 100-250 psi
			500: 250-500 psi
			750: 500-750 psi



RV11 Series

BALL VALVES*

- ▶ Material: 316
- ▶ Washer: PTFE
- ▶ Maximum pressure: 3000 psi, 2500 psi
- ▶ Connections: NPT, GENLOK, FSR



SS-BV Series

CHECK VALVES*

- ▶ Material: 316
- ▶ Washer: Viton (other material available)
- ▶ Maximum pressure: 3000 psi
- ▶ Pressure options: 1, 3, 5, 10, 25 psi
- ▶ Connections: NPT, GENLOK
- ▶ Size: 1/8", 1/4", 3/8", 1/2", 3/4", 1"



SS-CV Series

* Please see "Valves" catalogue for more information

ACCESSORIES

DIAPHRAGM VALVES*



SL-DV51-NT4-FNT4

Series	CV	Inlet Connection	-	Outlet Connection	Description
SL-DV51-NT4-FNT4	0.17	1/4" NPT	-	1/4" NPT(F)	Designed for regulator outlet port
BP-DV11-NT4-FNT4	0.17	1/4" NPT	-	1/4" NPT(F)	Designed for regulator outlet port

* Please see "Valves" catalogue for more information

TUBE FITTINGS**



SS-MC-TF4-NT4



SS-UE-TF8



R120-52P

Series	-	Material	-	Description
R195-51		Brass		1/4" NPT(M) x 1/4" NPT(M)
R195-51P		Chrome-plated brass		1/4" NPT(M) x 1/4" NPT(M)
R952-5503		316		1/4" NPT(M) x 1/4" NPT(M)
R120-52		Brass		1/4" NPT(M) x M16(RH)
R110-52		Brass		1/4" NPT(M) x M16(LH)
R120-52P		Chrome-plated brass		1/4" NPT(M) x M16(RH)
R110-52P		Chrome-plated brass		1/4" NPT(M) x M16(LH)
R952-52L		316		1/4" NPT(M) x M16(RH)
R952-52AL		316		1/4" NPT(M) x M16(LH)
SS-MC-TF4-NT4		316		1/4" NPT(M) x 1/4" GENLOK
SS-MC-TF6-NT4		316		1/4" NPT(M) x 3/8" GENLOK
SS-MC-TF8-NT4		316		1/4" NPT(M) x 1/2" GENLOK
SS-MC-TF8-NT8		316		1/2" NPT(M) x 1/2" GENLOK
SS-UE-TF8		316		1/2" GENLOK x 1/2" GENLOK

** Please see "Tube Fittings" catalogue for more information

■ ACCESSORIES

CYLINDER CONNECTIONS



CGA 320 Series

BS 341	Model No.	Material	Nut	Nipple	Washer
No. 2	SS-BS341-2	Stainless Steel	G5/8-14 (Left Hand)	3" Length (1/4" NPT)	\
	BP-BS341-2	Chrome-Plated Brass			
No. 3	SS-BS341-3	Stainless Steel	G5/8-14 (Right Hand)	3" Length (1/4" NPT)	\
	BP-BS341-3	Chrome-Plated Brass			
No. 4	SS-BS341-4	Stainless Steel	G5/8-14 (Left Hand)	3" Length (1/4" NPT)	\
	BP-BS341-4	Chrome-Plated Brass			
DIN 477	Model No.	Material	Nut	Nipple	Washer
No. 5	SS-DIN477-5	Stainless Steel	1"-11 (Left Hand)	2-1/2" Length (1/4" NPT)	Nylon
	BP-DIN477-5	Chrome-Plated Brass			
No. 6	SS-DIN477-6	Stainless Steel	W21.8-14 (Right Hand)	2.35" Length (1/4" NPT)	Nylon
	BP-DIN477-6	Chrome-Plated Brass			
No. 8	SS-DIN477-8	Stainless Steel	1"-11 (Right Hand)	2.35" Length (1/4" NPT)	Nylon
	BP-DIN477-8	Chrome-Plated Brass			
CGA	Model No.	Material	Nut	Nipple	Washer
320	SS-CGA320	Stainless Steel	0.830-14NGO (Right Hand)	2" Length (1/4" NPT)	Nylon
	BP-CGA320	Chrome-Plated Brass			
330	SS-CGA330	Stainless Steel	0.830-14NGO (Left Hand)	2" Length (1/4" NPT)	Nylon
	BP-CGA330	Chrome-Plated Brass			
350	SS-CGA350	Stainless Steel	0.830-14NGO (Left Hand)	2-1/2" Length (1/4" NPT)	Nylon
	BP-CGA350	Chrome-Plated Brass			
410	SS-CGA410	Stainless Steel	0.855-14NGO (Left Hand)	2-1/2" Length (1/4" NPT)	Nylon
	BP-CGA410	Chrome-Plated Brass			
580	SS-CGA580	Stainless Steel	0.960-14NGO (Right Hand)	3" Length (1/4" NPT)	\
	BP-CGA580	Chrome-Plated Brass			
590	SS-CGA590	Stainless Steel	0.960-14NGO (Left Hand)	3" Length (1/4" NPT)	\
	BP-CGA590	Chrome-Plated Brass			
660	SS-CGA660	Stainless Steel	1.035-14NGO (Right Hand)	2" Length (1/4" NPT)	Nylon
	BP-CGA660	Chrome-Plated Brass			

MATERIAL COMPATIBILITY TABLE

Gas	Materials												
	Aluminum	Brass	Copper	Mone	Stainless Steel	Carbon Steel	Neoprene	PCTFE (Kel-F)	Viton	Polyethyler	PVC	PTFE (Teflon)	
Ammonia	◇	◆	◆	☆	◇	◆	◇	◇	◆	◆	◇	◇	
Argon	◇	◇	◇	◇	◇	◇	◇	◇	◇	◇	◇	◇	
CO ₂	◇	◇	◇	◇	◇	◇	◇	◇	◇	◇	◇	◇	
Chlorine	◆	◆	◆	◇	☆	◇	◆	◇	◇	◇	◆	◇	
Diborane	◇	◇	◇	◇	◇	◇	◆	◇	◇	◆	◆	◇	
Helium	◇	◇	◇	◇	◇	◇	◇	◇	◇	◇	◇	◇	
Hydrogen	◇	◇	◇	◇	◇	◇	◇	◇	◇	◇	◇	◇	
HCl	◆	◆	◆	◇	☆	◆	◇	◇	◇	◇	◇	◇	
H ₂ S	☆	◆	◆	☆	◇	◆	◆	◇	◇	◇	◇	◇	
Methane	◇	◇	◇	◇	◇	◇	◇	◇	◇	◇	◇	◇	
Nitrogen	◇	◇	◇	◇	◇	◇	◇	◇	◇	◇	◇	◇	
N ₂ O	◇	◇	◇	◇	◇	◇	◇	◇	◇	◇	◇	◇	
Oxygen	◇	◇	◇	◇	◇	◇	◇	◇	◇	◆	◆	◇	
Phosphine	◇	◆	◆	◇	◇	◇	◆	◇	◇	◇	◇	◇	
Silane	◇	◇	◇	◇	◇	◇	◇	◇	◇	◇	◇	◇	
SO ₂	◇	◇	☆	◇	◇	◇	◆	◇	◆	◇	◇	◇	
F ₆ S	◇	◇	◇	◇	◇	◇	◇	◇	◇	◇	◇	◇	
Arsine	◆	◇	◆	◇	◇	◇	◇	◇	◇	◇	◇	◇	
Boron Trichloride	◆	◆	◇	◇	◇	◇	◆	◇	◇	◆	◇	◇	
Boron Trifluoride	◇	◆	◇	◇	◇	◇	◆	◇	◆	◆	◇	◇	
Dichlorosilane	◆	◆	◆	◇	◇	◇	◆	◇	◆	◆	◆	◇	
Silicon Tetrachloride	◆	◆	◆	◇	◇	◇	◆	◇	◆	◆	◆	◇	
Acetylene	◇	◇	◆	◇	◇	◇	◇	◇	◇	◇	◆	◇	
Air	◇	◇	◇	◇	◇	◇	◇	◇	◇	◇	◇	◇	
Butane	◇	◇	◇	◇	◇	◇	◇	◇	◇	◆	◇	◇	
Carbon Monoxide	◇	◇	◇	◇	◇	◇	◆	◇	◇	◇	◇	◇	
Cyclopropane	◇	◇	◇	◇	◇	◇	◇	◇	◇	◇	◇	◇	
Ethane	◇	◇	◇	◇	◇	◇	◇	◇	◇	◇	◇	◇	
Ethylene	◇	◇	◇	◇	◇	◇	◇	◇	◇	◇	◆	◇	
Ethylene Oxide	◆	◆	◆	◇	◇	◇	◆	◇	◆	◆	◆	◇	
Isobutane	◇	◇	◇	◇	◇	◇	◇	◇	◇	◆	◇	◇	
Krypton	◇	◇	◇	◇	◇	◇	◇	◇	◇	◇	◇	◇	
Methyl Chloride	◆	◆	☆	◇	◇	◇	◇	◇	◇	◇	◆	◇	
Neon	◇	◇	◇	◇	◇	◇	◇	◇	◇	◇	◇	◇	
NO	◇	◆	◆	◆	◇	☆	◆	◇	◇	◇	◇	◇	
Propane	◇	◇	◇	◇	◇	◇	◇	◇	◇	◇	◇	◇	
Xenon	◇	◇	◇	◇	◇	◇	◇	◇	◇	◇	◇	◇	

◇ Recommended

◆ Not recommended

☆ Recommended only for dry-grades of gas

CYLINDER CONNECTIONS ALLOCATION TABLE

Gas	BSP	DIN	CGA	UHP CGA	JIS
Acetylene	BS 341 nr.2	/	510	/	/
Air	BS 341 nr.3	/	346	/	/
Ammonia	BS 341 nr.10	DIN 6	705	720	22-R
Argon	BS 341 nr.3	DIN 6	580	718	22-4 or 23-R
Arsine	/	/	350	632	22-L
Boron Trichloride	/	DIN 8	660	634	/
Boron Trifluoride	/	DIN 8	330	642	22-L
Butane	BS 341 nr.4	/	510	/	/
Carbon Dioxide	BS 341 nr.8	DIN 6	320	716	/
Carbon Monoxide	BS 341 nr.4	DIN 5	350	724	22-L
Cyclopropane	BS 341 nr.4	/	510	/	/
Diborane	/	/	350	632	22-L
Dichlorosilane	/	DIN 5	678	636	/
Diethylzinc	/	/	510	726	/
Ethane	/	/	350	/	/
Ethyl Chloride	/	/	510	/	/
Ethylene	/	/	350	/	/
Ethylene Oxide	/	/	510	/	/
Germane	/	/	350 or 660	632	/
R11 (R116) / Halocarbon 11 (116)	/	/	660	716	/
R12 (R13, R23, R115) / Halocarbon 12 (13,23,115)	/	DIN 6	660	716	/
R14 (Halocarbon 14)	/	DIN 6	320 or 580	716	/
Helium	BS 341 nr.3	DIN 6	580	718	22-R or 23-R
Hydrogen	BS 341 nr.2	DIN 1	350	724	22-L
Hydrogen Chloride	/	DIN 8	330	634	26-R
Hydrogen Fluoride	/	/	660 or 670	638	26-R
Hydrogen Sulfide	/	DIN 5	330	722	/
Iso-Butane	/	/	510	/	/
Krypton	/	DIN 6	580	718	22-R or 23-R
Methane	BS 341 nr.2	/	350	/	/
Methyl Chloride	/	/	660	/	/
Natural Gas	/	/	350	/	/
Neon	/	DIN 6	580	718	22-R or 23-R
Nitric Oxide	/	/	660	/	/
Nitrogen	BS 341 nr.3	DIN 10	580	718	22-R or 23-R
Nitrogen Trifluoride	/	DIN 8	330 or 670	640	/
Nitrous Oxide	BS 341 nr.13	DIN 8	326	712	/
Oxygen	BS 341 nr.3	DIN 9	540	714	22-R or 23-R
Phosphine	/	DIN 1	350	632	/
Propane	BS 341 nr.4	/	510	/	/
Silane	/	/	350	632	/
Silicon Tetrachloride	/	/	330	636	/
Silicon Tetrafluoride	/	/	330	642	22-L
Sulfur Hexafluoride	/	DIN 6	590	716	26-R
Tungsten Hexafluoride	/	DIN 8	670	638	/
Xenon	/	DIN 6	580	718	22-R

* Chart is for reference only



Ultra High Purity

- ▶ Regulators
- ▶ Diaphragm Valves
- ▶ Gauges
- ▶ Fittings



F Series Filters

- ▶ Inline Filter
- ▶ T-type Filter



Valves

- ▶ Needle valves
- ▶ Ball valves
- ▶ Diaphragm valves
- ▶ Cylinder valves
- ▶ Gauge valves
- ▶ Check valves



Tube Fittings

- ▶ Male connectors
- ▶ Male elbows
- ▶ Male adapters
- ▶ Female connectors
- ▶ Female elbows
- ▶ Unions
- ▶ Reducing unions



Genstar Technologies Company Inc.

4525 Edison Avenue, Chino, CA 91710, USA

Tel: 909-606-2726

Fax: 909-606-6485

www.genstartech.com