

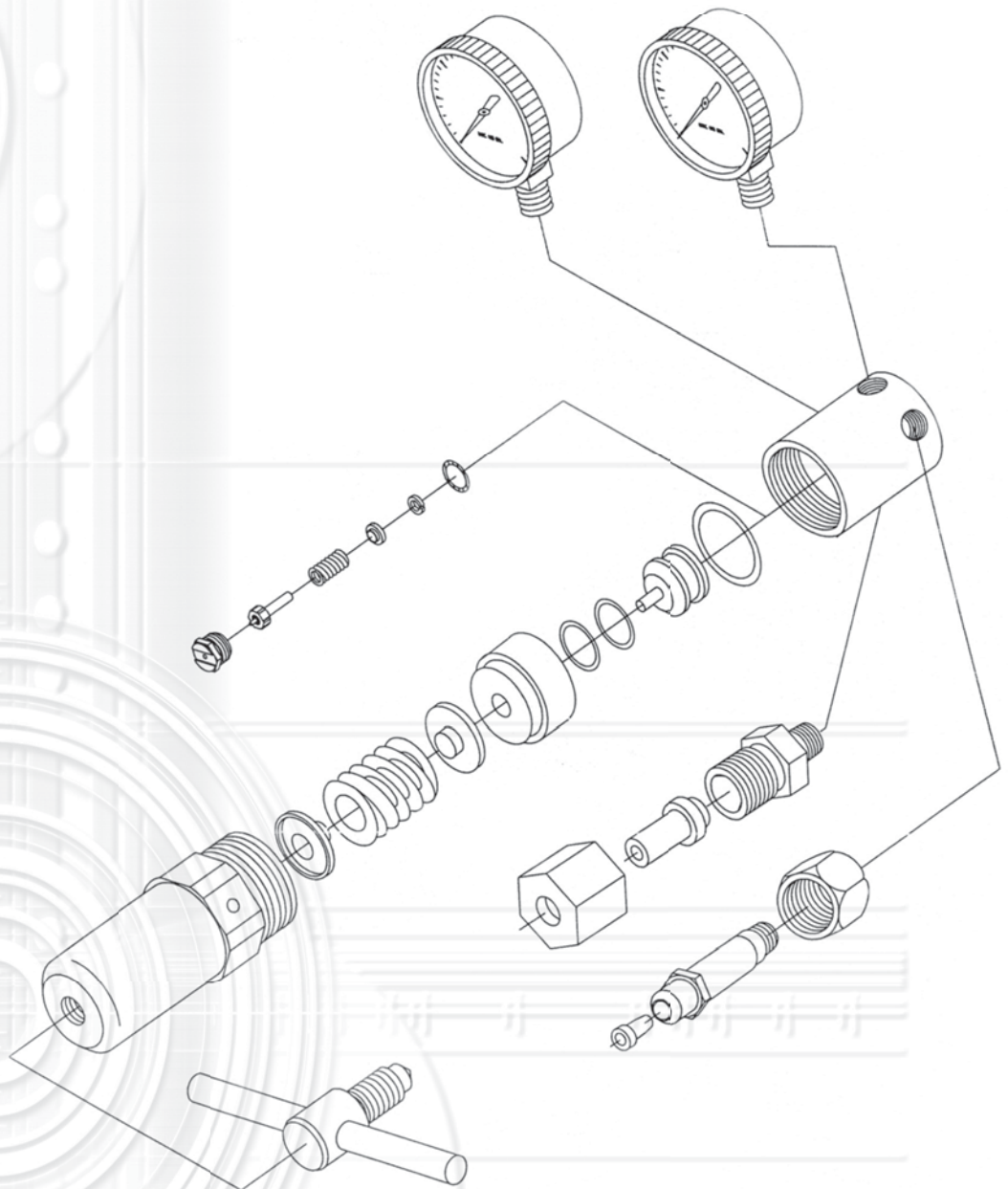

# GENSTAR TECHNOLOGIES

## Regulators & Flowmeters Repair Parts Catalog

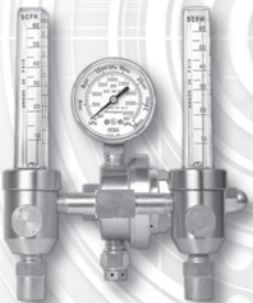

Sustaining Member

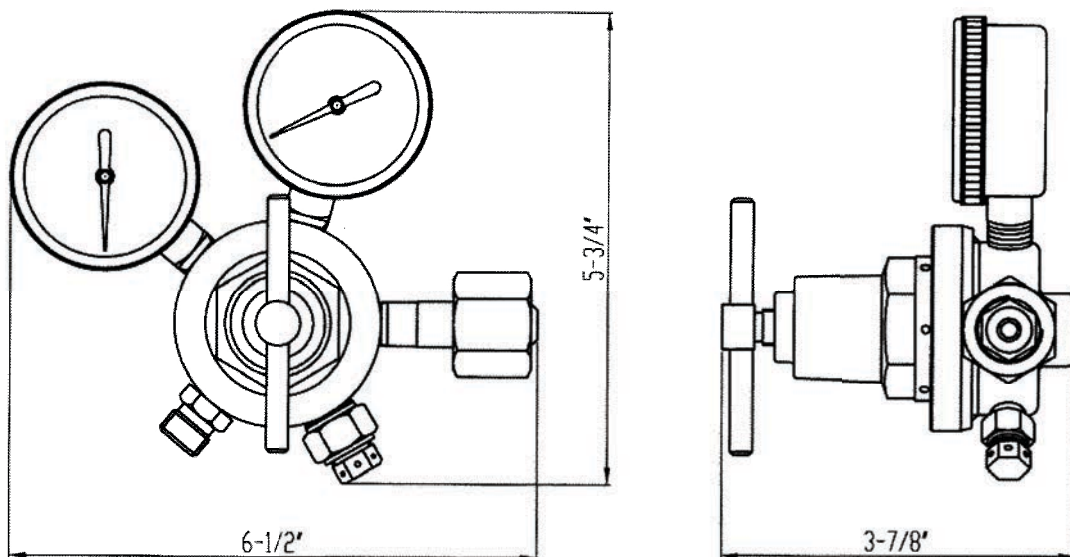

**MODEL INFORMATION**

GAS SERVICE	MODEL NUMBER	MAX. DELIVERY PRESSURE (PSI)	INLET CONNECTION	OUTLET CONNECTION
OXYGEN	152X-80	4-80	CGA540	9/16"-18RH(M)
ACETYLENE	152Y-15	2-15	CGA510	9/16"-18LH(M)
	152Y-15-3	2-15	CGA300	9/16"-18LH(M)
	152Y-15-5	2-15	CGA520	9/16"-18LH(M)
INERT GAS (Ar,He,N2)	152IN-125	5-125	CGA580	5/8"-18RH(M)
AIR	152Q-125	5-125	CGA346	9/16"-18RH(M)
ARGON (Ar/CO2)	152AR-100	0-100(SCFH)	CGA580	5/8"-18RH(F)
CARBON DIOXIDE	152CD-100	0-100(SCFH)	CGA320	5/8"-18RH(F)

**CHART 1**

Description	152Y-15 152Y-15-3 152Y-15-5	152F-80	152X-80	152IN-125 152Q-125	152AR-100	152CD-100
Adjusting Spring	R130-07	R140-07	R140-07	R452N-07	R140-07	R140-07
H.P. Gauge	G20-400	G20-400	G20-4000	G20-4000	G20-4000	G20-4000
L.P. Gauge	G20-030R	G20-100	G20-100	G20-200	G20-100CF	G20-D100CF
Body	R130-50	R130-50	R140-50	R140-50	R140-50	R140-50

**CHART 2**

**Relief Valve**

Description	152X-80 152AR-100 152CD-100	152IN-125 152Q-125
Relief Valve	R140-87	R160-87
Spring	R140-75	R160-75

CHART 3

Gas Service	CGA INLET	Inlet Stem	Inlet Nut	Seat Assembly	Nozzle	Outlet Connection
Oxygen	540	R120-58	R120-57	R120-83	R110-30	R120-53
LPG	510	R110-55	R110-54	R130-83	R130-30	R110-53
Acetylene	510	R110-55	R110-54	R130-83	R130-30	R110-53
	300	R110-58	806-1	R130-83	R130-30	R110-53
	520	300-3SF	300-2	R130-83	R130-30	R110-53
Inert Gas (Ar,He,N2)	580	RNP15-3SF	R190-54	R120-83	R110-30	R195-52
Air	346	R120-58N	R120-57B	R120-83	R110-30	R120-53
ARGON (Ar/CO2)	580	R110-55	R190-54	R120-83	R110-30	R195-52
CARBON DIOXIDE	320	CO-3	806-1	R120-83	R110-30	R195-52B

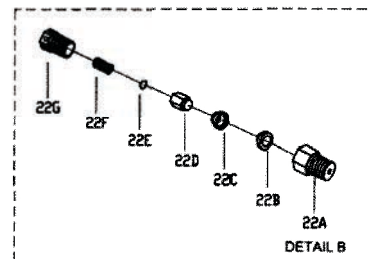
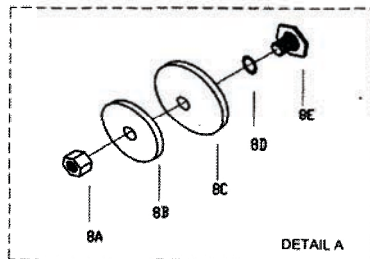
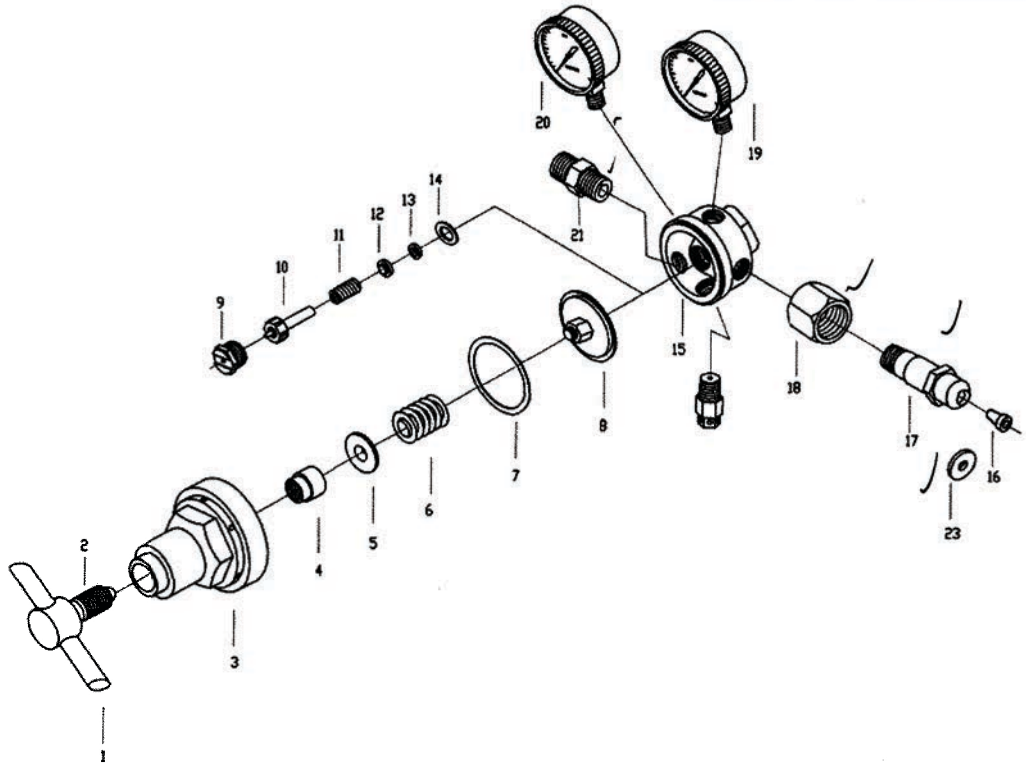

Ref. No.	Part Description	Part No.
1	Adjusting Screw	R130-01-01
2	Adjusting Stem	R130-01-02
3	Housing Cap	R130-04
4	Cap Bushing	R130-05
5	Spring Button	R130-06
6	Adjusting Spring	See Chart 1
7	Slip Ring	R130-08
8	✦ Diaphragm Assembly	R130-82A
8A	Diaphragm Nut	R240-10
8B	Diaphragm Plate	R130-14
8C	Seal Washer	R130-15
8D	Diaphragm	R130-16D
8E	Centralizer	R130-18
9	Nozzle	See Chart 3
10	✦ Seat Assembly	See Chart 3
11	Valve Spring	R110-35
12	Gland	R110-36
13	✦ Friction Washer	R110-37
14	✦ Gasket	R110-38
15	Body	See Chart 1
16	✦ Filter	R110-56
17	Inlet Stem	See Chart 3
18	✦ Inlet Nut	See Chart 3
19	✦ H.P. Gauge	See Chart 1
20	✦ L.P. Gauge	See Chart 1
21	✦ Outlet Connection	See Chart 3
22	Relief Valve	See Chart 2
22A	Valve Body	R140-70
22B	Seat	R140-71
22C	Seat Retainer	R140-72
22D	Upper Seat	R140-73
22E	Disc	R140-74
22F	Spring	See Chart 2
22G	Cap	R140-76
23	✦ Washer	CO-6N

Notice: Ref. No.23 CO-6N for CGA320 only.

✦ Items most commonly required for regulator repair and recommended for stock.

Repair kits include these items.

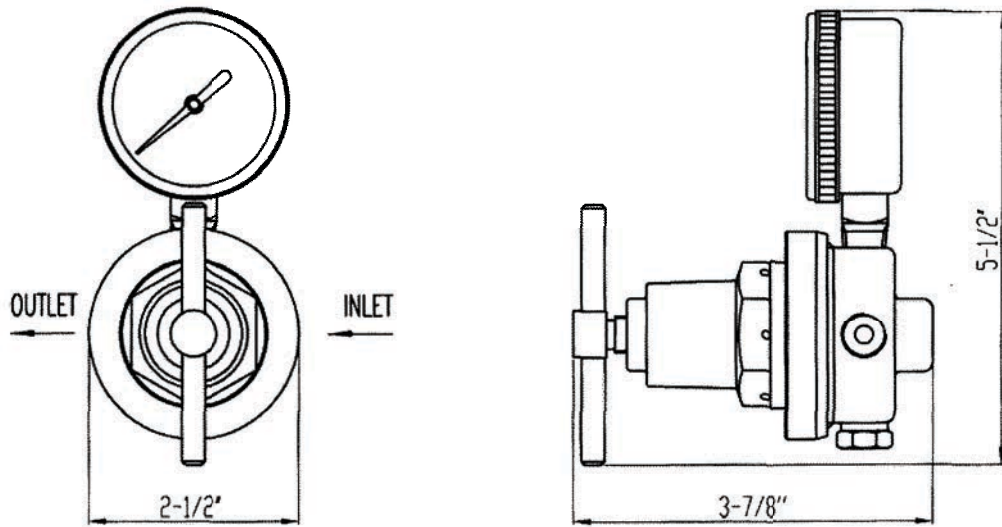

## MODEL INFORMATION

GAS SERVICE	MODEL NUMBER	MAX. DELIVERY PRESSURE (PSI)	INLET CONNECTION	OUTLET CONNECTION
L.P.G. GAS	152LF-80	4-80	1/4"NPT(F)	1/4"NPT(F)
OXYGEN	152LX-80	4-80	1/4"NPT(F)	1/4"NPT(F)
	152LX-125	5-125	1/4"NPT(F)	1/4"NPT(F)
	152LX-200	10-200	1/4"NPT(F)	1/4"NPT(F)
ACETYLENE	152LY-15	2-15	1/4"NPT(F)	1/4"NPT(F)
INERT GAS (Ar,He,N2)	152LIN-125	5-125	1/4"NPT(F)	1/4"NPT(F)
AIR	152Q-125	5-125	1/4"NPT(F)	1/4"NPT(F)

CHART 1

Description	152LY-15	152LF-80	152LX-80	152LX-200	152LIN-125 152LX-125 152LC-125
Adjusting Spring	R130-07	R140-07	R140-07	R452N-07	R452N-07
L.P. Gauge	G20-030R	G20-100	G20-100	G20-400	G20-200

CHART 2

Gas Service	Inlet Stem	Inlet Nut	Nozzle	Seat Assembly	Outlet Connection
Oxygen	N/A	N/A	R130-30	R120-83A	N/A
LPG	N/A	N/A	R130-30	R130-83	N/A
Acetylene	N/A	N/A	R130-30	R130-83	N/A
Inert Gas (Ar,He,N2)	N/A	N/A	R130-30	R120-83A	N/A

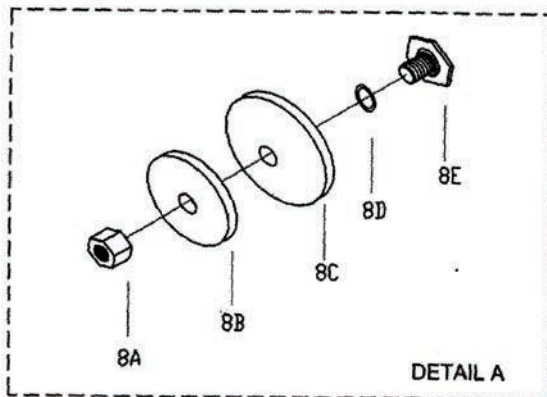
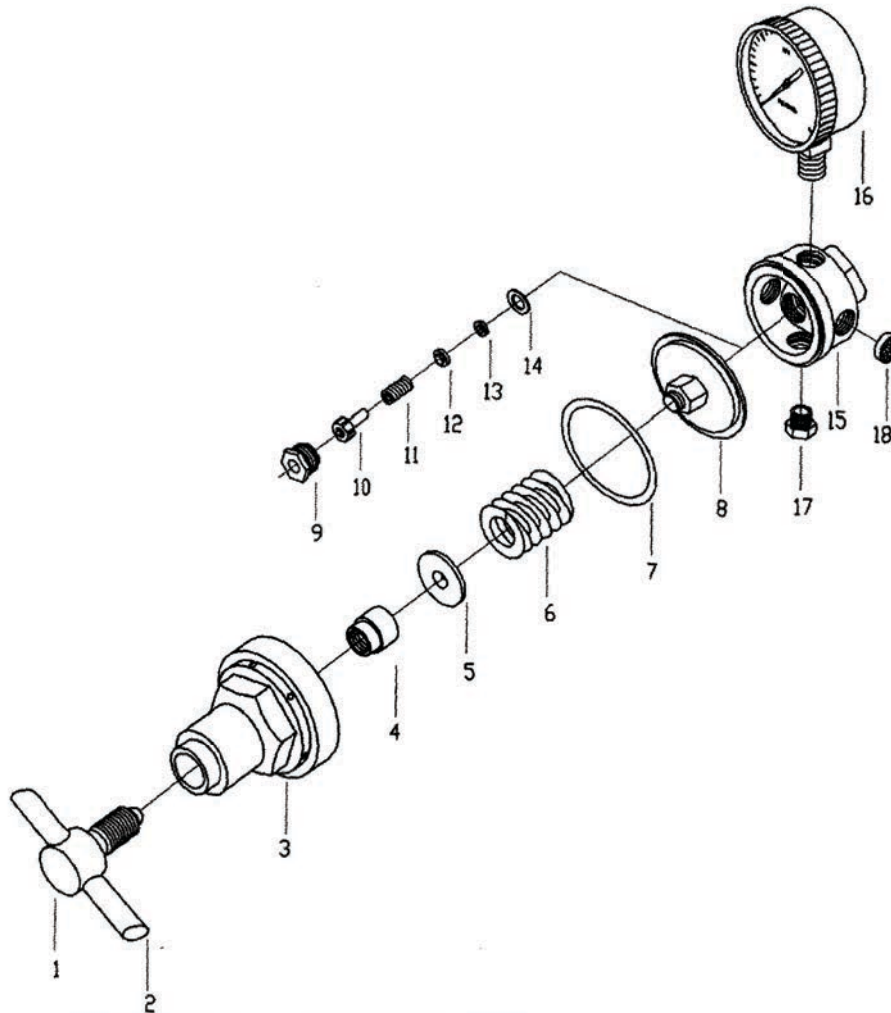

---

Ref. No.	Part Description	Part No.
1	Adjusting Screw	R130-01-01
2	Adjusting Stem	R130-01-02
3	Housing Cap	R130-04
4	Cap Bushing	R130-05
5	Spring Button	R130-06
6	Adjusting Spring	See Chart 1
7	Slip Ring	R130-08
8	✦ Diaphragm Assembly	R130-82A
8A	Diaphragm Nut	R240-10
8B	Diaphragm Plate	R130-14
8C	Seal Washer	R130-15
8D	Diaphragm	R130-16D
8E	Centralizer	R130-18
9	Nozzle	See Chart 2
10	✦ Seat Assembly	See Chart 2
11	Valve Spring	R110-35
12	Gland	R110-36
13	✦ Friction Washer	R110-37
14	✦ Gasket	R110-38
15	Body	R130-50S
16	✦ L.P. Gauge	See Chart 1
17	Pipe Plug	RP-4HP
18	✦ Filter	R130-56

---

✦ Items most commonly required for regulator repair and recommended for stock.  
Repair kits include these items.

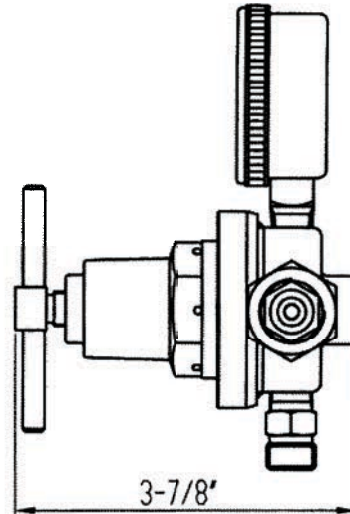
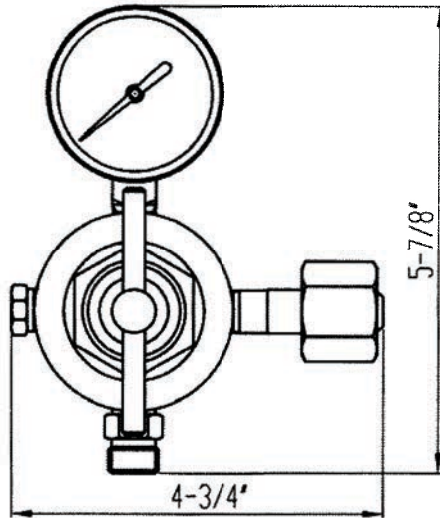

## MODEL INFORMATION

GAS SERVICE	MODEL NUMBER	MAX. DELIVERY PRESSURE (PSI)	INLET CONNECTION	OUTLET CONNECTION
L.P.G. GAS	152SF-80	4-80	7/8"-14LH(F)	9/16"-18LH(M)
	152SF-125	5-125	7/8"-14LH(F)	9/16"-18LH(M)
OXYGEN	152SX-40	2-40	7/8"-14RH(F)	9/16"-18RH(M)
	152SX-80	4-80	7/8"-14RH(F)	9/16"-18RH(M)
	152LX-125	5-125	7/8"-14RH(F)	9/16"-18RH(M)
ACETYLENE	152SY-15	2-15	7/8"-14LH(F)	9/16"-18LH(M)
INERT GAS CO2 AIR	152SIN-40	2-40	7/8"-14RH(M)	5/8"-18RH(F)
	152SIN-80	4-80	7/8"-14RH(M)	5/8"-18RH(F)
	152SIN-125	5-125	7/8"-14RH(M)	5/8"-18RH(F)
	152SIN-40FG	0-40(SCFH)	7/8"-14RH(M)	5/8"-18RH(F)

CHART 1

Description	152SY-15	152SF-80 152SIN-80 152SX-80	152SX-40 152SIN-40	152SIN-40FG	152SIN-125 152SX-125 152SF-125
Adjusting Spring	R130-07	R140-07	R152X-07	R140-07	R452N-07
L.P. Gauge	G20-030R	G20-100	G20-60	G20-D50CF	G20-200

CHART 2

Gas Service	Inlet Stem	Inlet Nut	Nozzle	Seat Assembly	Outlet Connection
Oxygen	R155-104	R155-105	R110-30	R120-83	R120-53
LPG	R155-104	R155-106	R130-30	R130-83	R110-53
Acetylene	R155-104	R155-106	R130-30	R130-83	R110-53
Inert Gas	R120-58E	R120-57E	R110-30	R120-83	R195-52
Air CO2	R120-58E	R120-57E	R110-30	R120-83	R190-52



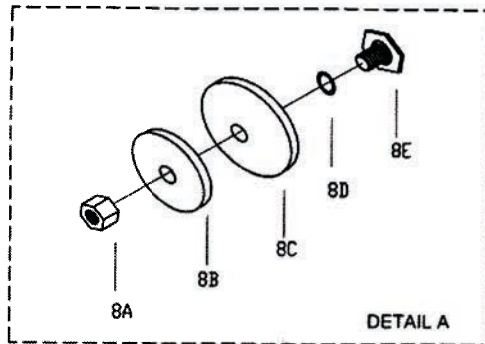
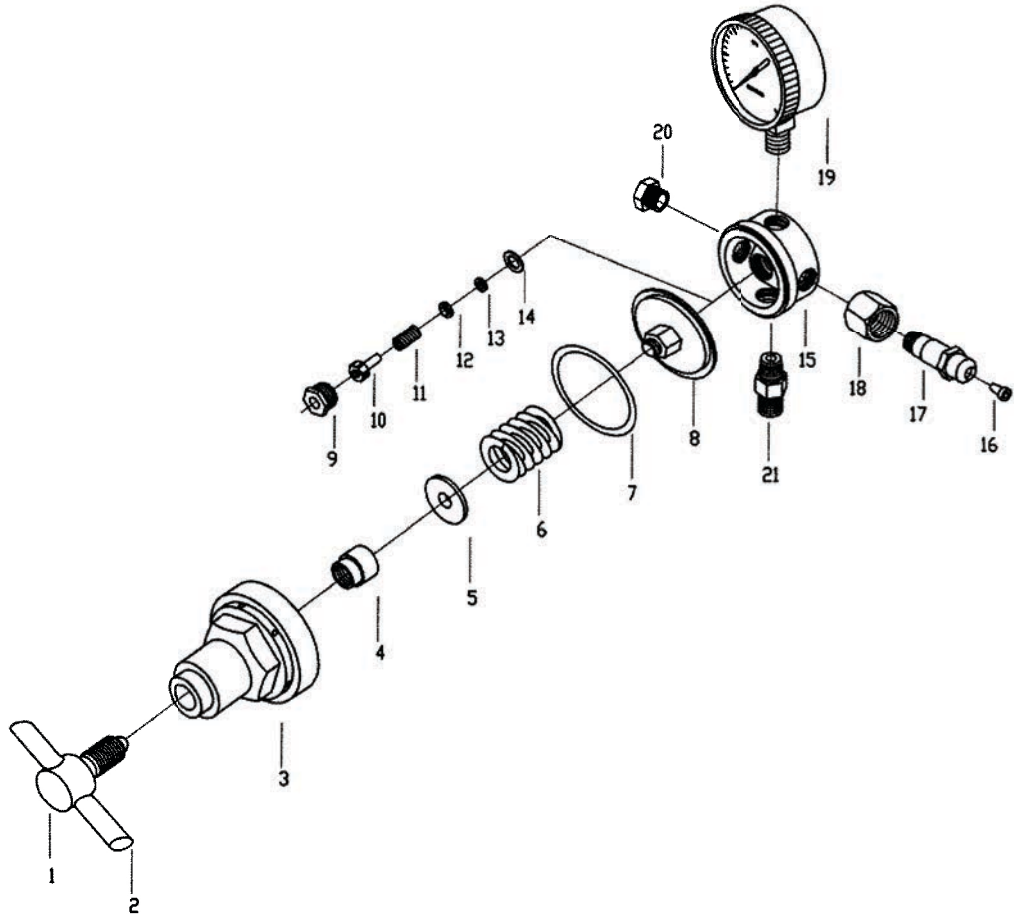

Ref. No.	Part Description	Part No.
1	Adjusting Screw	R130-01-01
2	Adjusting Stem	R130-01-02
3	Housing Cap	R130-04
4	Cap Bushing	R130-05
5	Spring Button	R130-06
6	Adjusting Spring	See Chart 1
7	Slip Ring	R130-08
8	✦ Diaphragm Assembly	R130-82A
8A	Diaphragm Nut	R240-10
8B	Diaphragm Plate	R130-14
8C	Seal Washer	R130-15
8D	Diaphragm	R130-06D
8E	Centralizer	R130-18
9	Nozzle	See Chart 2
10	✦ Seat Assembly	See Chart 2
11	Valve Spring	R110-35
12	Gland	R110-36
13	✦ Friction Washer	R110-37
14	✦ Gasket	R110-38
15	Body	R130-50S
16	✦ Filter	R110-56
17	Inlet Stem	See Chart 2
18	✦ Inlet Nut	See Chart 2
19	✦ L.P. Gauge	See Chart 1
20	Pipe Plug	RP-4HP
21	✦ Outlet Connection	See Chart 2

✦ Items most commonly required for regulator repair and recommended for stock.  
Repair kits include these items.

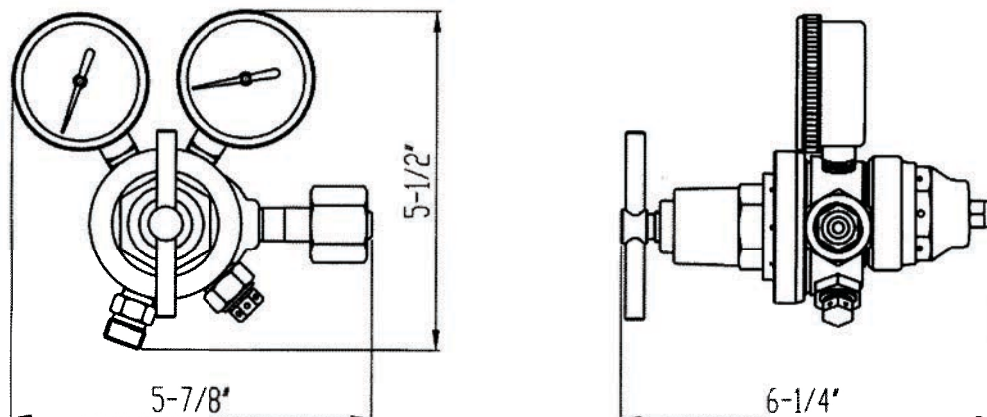

## MODEL INFORMATION

GAS SERVICE	MODEL NUMBER	MAX. DELIVERY PRESSURE (PSI)	INLET CONNECTION	OUTLET CONNECTION
L.P.G GAS	152TF-80	4-80	CGA510	9/16"-18LH(M)
OXYGEN	152TX-80	4-80	CGA540	9/16"-18RH(M)
ACETYLENE	152TY-15	2-15	CGA510	9/16"-18LH(M)
	152Y-15-3	2-15	CGA300	9/16"-18LH(M)
INERT GAS (Ar,He,N2)	152TIN-125	5-125	CGA580	5/8"-18RH(M)
AIR	152TQ-125	5-125	CGA346	9/16"-18RH(M)

CHART 1

Description	152TY-15 152TY-15-3	152TF-80	152TX-80	152TIN-125 152TQ-125
L. P. Adjusting Spring	R130-07	R140-07	R140-07	R452N-07
H. P. Adjusting Spring	R120-07	R190N-07	R190N-07	R190N-07
H.P. Gauge	G20-400	G20-400	G20-4000	G20-4000
L.P. Gauge	G20-030R	G20-100	G20-100	G20-200
Relief Valve	N/A	N/A	R153N-87	R153N-87
Plug	RP-4HP	RP-4HP	N/A	N/A

CHART 2

Gas Service	CGA INLET	Inlet Stem	Inlet Nut	L.P.Seat Assembly	H.P.Seat Assembly	Outlet Connection
Oxygen	540	R120-58	R120-57	R152T-83B	R160-83	R120-53
LPG	510	R110-55	R110-54	R150-83B	R150-83	R110-53
Acetylene	510	R110-55	R110-54	R150-83B	R150-83	R110-53
	300	R110-58	806-1	R150-83B	R150-83	R110-53
Inert Gas (Ar,He,N2)	580	R110-55	R120-54	R152T-83B	R160-83	R195-52
Air	346	R120-58N	R120-57B	R152T-83B	R160-83	R120-53

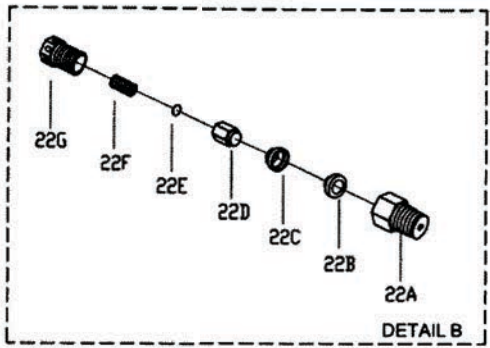
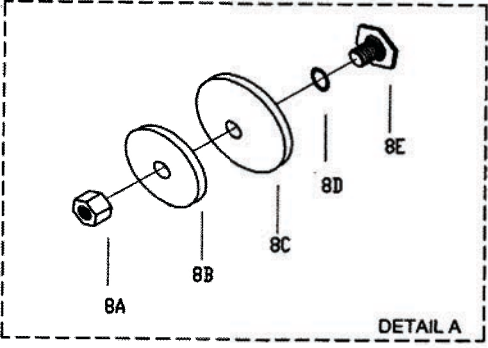
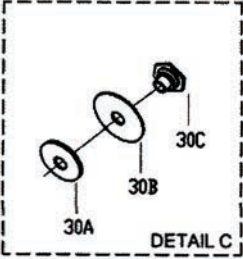
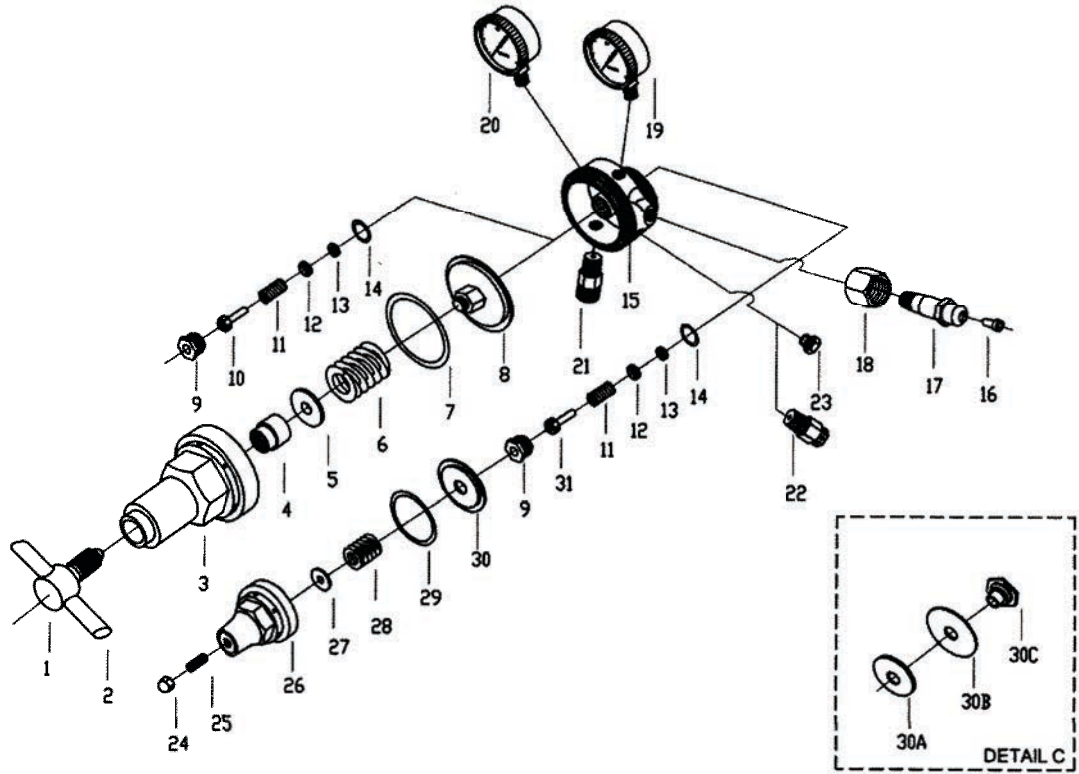

<b>Ref. No.</b>	<b>Part Description</b>	<b>Part No.</b>
1	Adjusting Screw	R130-01-01
2	Adjusting Stem	R130-01-02
3	Housing Cap	R130-04
4	Cap Bushing	R130-05
5	Spring Button	R130-06
6	L.P. Adjusting Spring	See Chart 1
7	Slip Ring	R130-08
8	✦ Diaphragm Assembly	R130-82A
8A	Diaphragm Nut	R240-10
8B	Diaphragm Plate	R130-14
8C	Seal Washer	R130-15
8D	Diaphragm	R130-16D
8E	Centralizer	R130-18
9	Nozzle	R130-30
10	✦ L.P. Seat Assembly	See Chart 2
11	Valve Spring	R150-35
12	Gland	R110-36
13	✦ Friction Washer	R110-37
14	✦ Gasket	R110-38
15	Body	R152T-50
16	✦ Filter	R110-56
17	Inlet Stem	See Chart 2
18	✦ Inlet Nut	See Chart 2
19	✦ H.P. Gauge	See Chart 1
20	✦ L.P. Gauge	See Chart 1
21	✦ Outlet Connection	See Chart 2
22	Relief Valve	R153N-87
22A	Valve Body	R153F-70
22B	Seat	R140-71
22C	Seat Retainer	R140-72
22D	Upper Seat	R153F-73
22E	Disc	R140-74
22F	Spring	R153F-75
22G	Cap	R153F-76
23	Pipe Plug	RP-4HP
24	Cap Nut	R195-01
25	Adjusting Screw	R195-02
26	Housing Cap	R152T-04
27	Spring Button	R110-06
28	H.P. Adjusting Spring	See Chart 1
29	Slip Ring	R152T-08

---

Ref. No.	Part Description	Part No.
30	✦ Diaphragm Assembly	R152T-82
30A	Diaphragm Plate	R110-14A
30B	Diaphragm	R152T-16
30C	Centralizer	R110-18
31	✦ H.P.Seat Assembly	See Chart 2

---

✦ Items most commonly required for regulator repair and recommended for stock.  
Repair kits include these items.

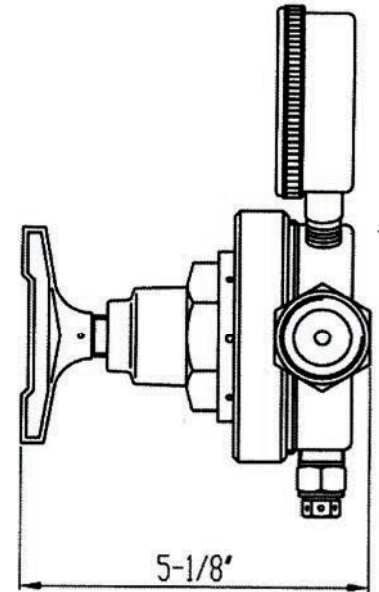
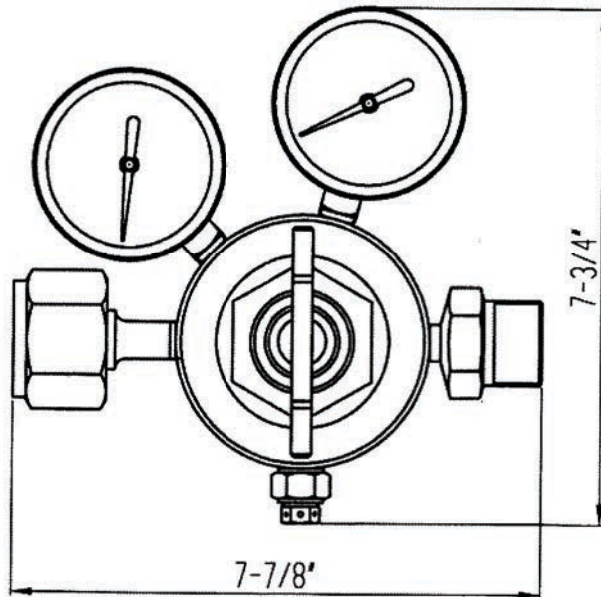

### MODEL INFORMATION

#### 153 SERIES

GAS SERVICE	MODEL NUMBER	MAX. DELIVERY PRESSURE (PSI)	INLET CONNECTION	OUTLET CONNECTION
L.P.G. GAS	153F-125	5-125	CGA510	9/16"-18LH(M)
OXYGEN	153X-125	5-125	CGA540	9/16"-18RH(M)
	153X-200	10-200	CGA540	9/16"-18RH(M)
ACETYLENE	153Y-15	2-15	CGA510	9/16"-18LH(M)
	153Y-15-3	2-15	CGA300	9/16"-18LH(M)
INERT GAS (Ar, HE, N <sub>2</sub> )	153IN-125	5-125	CGA580	5/8"-18RH(F)
	153IN-250	10-250	CGA580	5/8"-18RH(F)
	153IN-250-F	10-250	CGA580	1/4" SAME Flare
AIR	153Q-125	5-125	CGA346	9/16"-18RH(M)
	153Q-200	10-200	CGA346	9/16"-18RH(M)
CARBON DIOXIDE	153C-125	5-125	CGA320	5/8"-18RH(F)
	153C-200	10-200	CGA320	5/8"-18RH(F)
HYDROGEN METHANE	153H-125	5-125	CGA350	9/16"-18LH(M)
	153H-200	10-200	CGA350	9/16"-18LH(M)

#### 153M SERIES

GAS SERVICE	MODEL NUMBER	MAX. DELIVERY PRESSURE (PSI)	INLET CONNECTION	OUTLET CONNECTION
LPG	153MF-125	5-125	1"-11 1/2NPS LH(M)	1"-11 1/2NPS LH(F)
OXYGEN INERT GAS AIR	153MX-200	10-200	1"-11 1/2NPS RH(M)	1"-11 1/2NPS RH(F)
ACETYLENE	153MY-15	2-15	1"-11 1/2NPS LH(M)	1"-11 1/2NPS LH(F)
INERT GAS	153MIN-125	5-125	1"-11 1/2NPS RH(M)	1"-11 1/2NPS RH(F)

CHART 1

Description	153Y-15 153Y-15-3 153MY-15	153F-125 153MF-125	153Q-200 153C-200 153MX-200	153X-250 153IN-250 153IN-250-F
Adjusting Spring	R150-07	R160-07	R155-07 R155-07A	R155-07 R155-07A
H.P. Gauge	G25B-400	G25B-400	G25B-4000	G25B-4000
L.P. Gauge	G25B-030RL	G25B-200	G25B-400	G25B-400
Housing Cap	R150-81	R150-81	R155-81B	R155-04B
Spring Button	R150-06	R150-06	R155-06	R150-06
Relief Valve	N/A	N/A	R153-87	R153N-87

Description	153X-125 153IN-125 153Q-125 153MIN-125	153H-125	153H-200
Adjusting Spring	R160-07	R160-07	R155-07 R155-07A
H.P. Gauge	G25B-4000	G25B-4000	G25B-4000
L.P. Gauge	G25B-200	G25B-200	G25B-400
Housing Cap	R150-81	R150-81	R155-81B
Spring Button	R150-06	R150-06	R150-06
Relief Valve	R160-87	R152-87	R152-87A

CHART 2

Description	153Y-15 153Y-15-3 153F-125	153MY-15 153MF-125 153MX-200	153X-250 153IN-250 153Q-200 153C-200 153H-125 153X-125 153IN-125 153Q-125 153H-200 153IN-250-F
Body	R150-50	R153-50 M	R160-50

CHART 3

Relief Valve

Description	153X-125 153IN-125 153Q-125 153MIN-125	153X-250 153IN-250 153Q-200 153C-200 153MX-200	153H-125	153H-200
Relief Valve	R160-87	R153N-87	R152-87	R152-87A
Valve Body	R140-70	R153F-70	R140-70	R140-70
Upper Seat	R140-73	R153F-73	R140-73	R140-73
Spring	R160-75	R153F-75	R152-75	R153F-75
Cap	R140-76	R153F-76	/	/

CHART 4

Cylinder Regulators

Gas Service	CGA INLET	Inlet Stem	Inlet Nut	Seat Assembly	Outlet Connection
Oxygen	540	R120-58	R120-57	R160-83	R120-53
LPG	510	RNP15-3SF	R110-54	R150-83	R110-53
Acetylene	510	R110-55	R110-54	R150-83	R110-53
	300	RNP16-8SF	806-1	R150-83	R110-53
Inert Gas (Ar,He,N2)	580	R110-55	R190-54	R160-83	R195-52
	580	R110-55	R190-54	R160-83	ROB48F
Air	346	R120-58N	R120-57B	R160-83	R120-53
Carbon Dioxide	320	CO-3	806-1	R160-83	R195-52
Hydrogen Methane	350	R152H-58	R152H-57	R160-83	R110-53



### Manifold Regulators

Gas Service	Outlet Stem	Outlet Nut	Inlet Connection	Seat Assembly
Oxygen, Inert Gas Air	R155-111	R155-101	R155-103A	R160-83
Acetylene	R155-103A	R155-102	R155-110A	R150-83

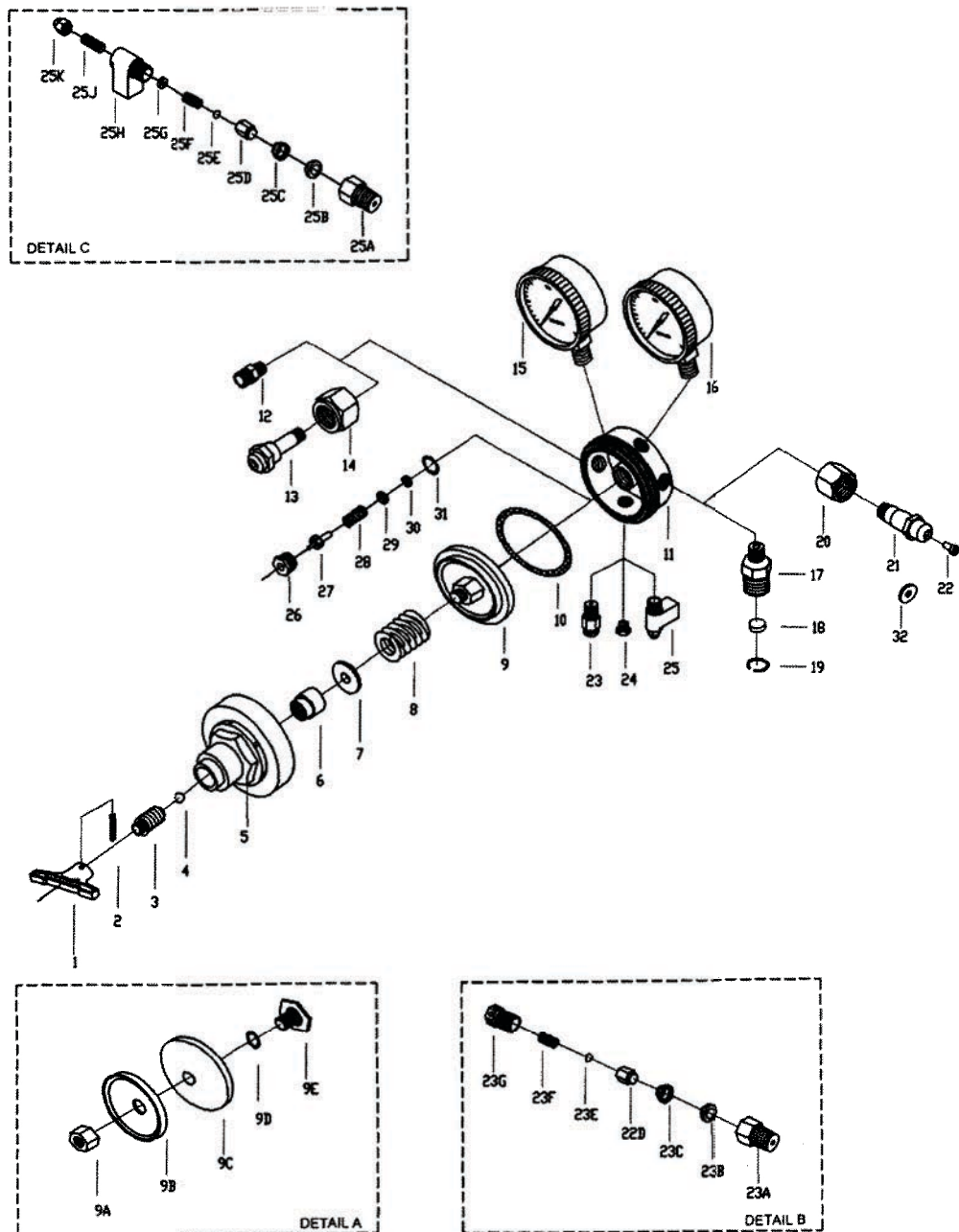

Ref. No.	Part Description	Part No.
1	Adjusting Knob	R150-01
2	Pin	R195-72
3	Adjusting Screw	R150-02
4	Steel Ball	R150-03
5	Housing Cap	See Chart 1
6	Cap Bushing	R150-05
7	Spring Button	R150-06
8	Adjusting Spring	See Chart 1
9	✦ Diaphragm Assembly	R160-82
9A	Diaphragm Nut	R150-10
9B	Diaphragm Plate	R150-14
9C	Diaphragm	R150-16
9D	O-Ring	R150-17
9E	Central Nut	R150-18
10	✦ O-Ring	R150-19
11	Body	See Chart 2
12	✦ Outlet Connection	See Chart 4
13	Outlet Stem	See Chart 4
14	✦ Outlet Nut	See Chart 4
15	✦ L.P. Gauge	See Chart 1
16	✦ H.P. Gauge	See Chart 1
17	Inlet Connection	See Chart 3
18	✦ Filter	R155M-56
19	✦ Retaining Ring	R155-120
20	✦ Inlet Nut	See Chart 4
21	Inlet Stem	See Chart 4
22	✦ Filter	R110-56
23	Relief Valve	See Chart 3
23A	Valve Body	See Chart 3
23B	Seat	R140-71
23C	Seat Retainer	R140-72
23D	Upper Seat	See Chart 3
23E	Disc	R140-74
23F	Spring	See Chart 3
23G	Cap	See Chart 3
24	Pipe Plug	RP-4HP
25	Vented Relief Valve	See Chart 3
25A	Valve Body	R140-70
25B	Seat	R140-71
25C	Seat Retainer	R140-72

---

Ref. No.	Part Description	Part No.
25D	Upper Seat	R140-73
25E	Disc	R140-74
25F	Spring	See Chart 3
25G	Spring Washer	R152-76
25H	Body	R152-77
25J	Screw	R195-02
25K	Cap Nut	R195-01
26	Nozzle	R155-30
27	✦ Seat Assembly	See Chart 4
28	Valve Spring	R150-35
29	Gland	R110-36
30	✦ Friction Washer	R110-37
31	✦ Gasket	R110-38
32	✦ Washer	CO-6N

---

Notice: Ref. No.32 CO-6N for CGA320 only.

✦ Items most commonly required for regulator repair and recommended for stock.

Repair kits include these items.

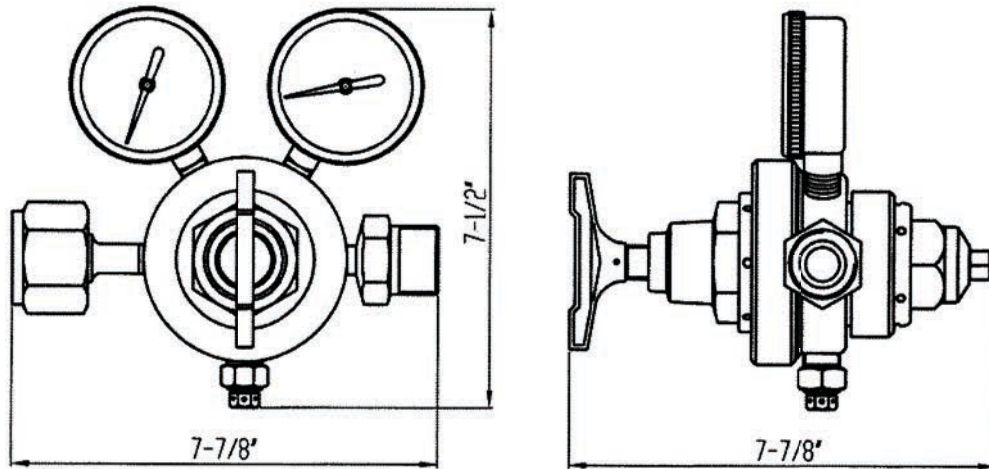

**MODEL INFORMATION**

**153T SERIES**

GAS SERVICE	MODEL NUMBER	MAX. DELIVERY PRESSURE (PSI)	INLET CONNECTION	OUTLET CONNECTION
L.P.G. GAS	153TF-125	5-125	CGA510	9/16"-18LH(M)
OXYGEN	153TX-125	5-125	CGA540	9/16"-18RH(M)
	153TX-250	10-250	CGA540	9/16"-18RH(M)
ACETYLENE	153TY-15	2-15	CGA510	9/16"-18LH(M)
	153TY-15-3	2-15	CGA300	9/16"-18LH(M)
INERT GAS (Ar, HE, N <sub>2</sub> )	153TIN-125	5-125	CGA580	5/8"-18RH(F)
	153TIN-250	10-250	CGA580	5/8"-18RH(F)
AIR	153TQ-125	5-125	CGA346	9/16"-18RH(M)
	153TQ-200	10-200	CGA346	9/16"-18RH(M)
CARBON DIOXIDE	153TC-125	5-125	CGA320	5/8"-18RH(F)
	153TC-200	10-200	CGA320	5/8"-18RH(F)

**153TM SERIES**

GAS SERVICE	MODEL NUMBER	MAX. DELIVERY PRESSURE (PSI)	INLET CONNECTION	OUTLET CONNECTION
OXYGEN INERT GAS AIR	153TMX-125	5-125	1"-11 1/2NPS RH(M)	1"-11 1/2NPS RH(F)
ACETYLENE	153TMY-15	2-15	1"-11 1/2NPS LH(M)	1"-11 1/2NPS LH(F)

**CHART 1**

Description	153TY-15 153TY-15-3 153TMY-15	153TF-125	153TX-250 153TIN-250 153TQ-200 153TC-200	153TX-125 153TIN-125 153TQ-125 153TMX-125
Adjusting Spring L.P	R150-07	R160-07	R155-07 R155-07A	R160-07
Adjusting Spring H.P	R253Y-07	R652-07A	R652-07A	R652-07A
H.P. Gauge	G25B-400	G25B-400	G25B-4000	G25B-4000
L.P. Gauge	G25B-030RL	G25B-200	G25B-400	G25B-200
Housing Cap	R150-81	R150-81	R155-81B	R150-81
Relief Valve	N/A	N/A	R153F-87	R153N-87

**CHART 2**  
Cylinder Regulators

Gas Service	CGA INLET	Inlet Stem	Inlet Nut	Seat Assembly	Outlet Connection
Oxygen	540	R120-58	R120-57	R160-83	R120-53
LPG	510	R110-55	R110-54	R150-83	R110-53
Acetylene	510	R110-58	R110-54	R150-83	R110-53
	300	R110-58	RNT16-2	R150-83	R110-53
Inert Gas (Ar,He,N2)	580	R110-55	R190-54	R160-83	R195-52
Air	346	R120-58N	R120-57B	R160-83	R120-53
Carbon Dioxide	320	CO-3	806-1	R160-83	R195-52

**Manifold Regulators**

Gas Service	Outlet Stem	Outlet Nut	Inlet Connection	Seat Assembly
Oxygen, Inert Gas Air	R155-103A	R155-101	R155-111	R160-83
Acetylene	R155-103A	R155-102	R155-111A	R150-83A

**CHART 3**  
Relief Valve

Description	153TX-250 153TIN-250 153TQ-200 153TC-200	153TX-125 153TIN-125 153TQ-125 153TMX-125
Relief Valve	R153F-87	R153N-87
Spring	R153F-75	R153N-75

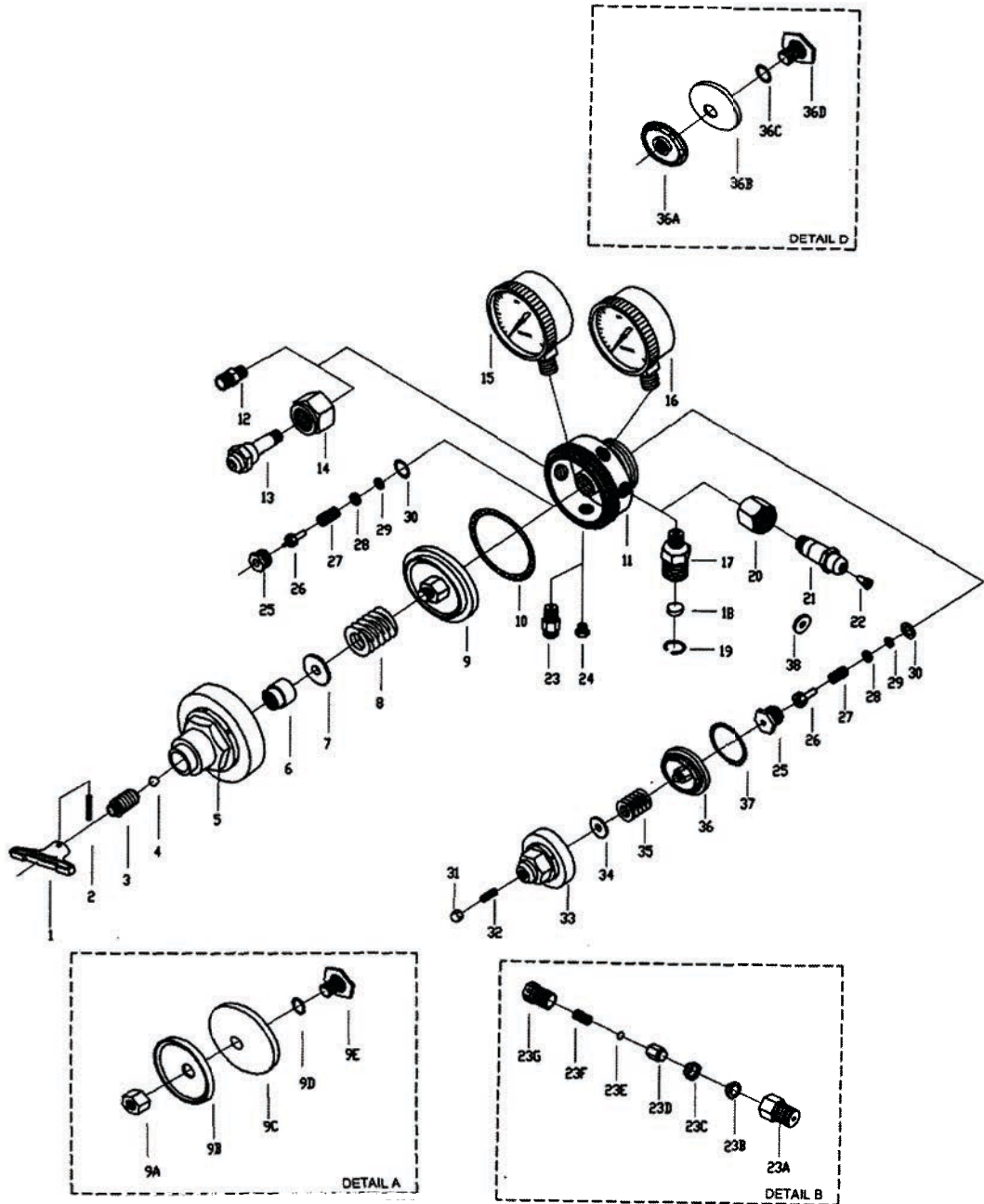

Ref. No.	Part Description	Part No.
1	Adjusting Knob	R150-01
2	Pin	R195-72
3	Adjusting Screw	R150-02
4	Steel Ball	R150-03
5	Housing Cap	See Chart 1
6	Cap Bushing	R150-05
7	Spring Button	R150-06
8	Adjusting Spring	See Chart 1
9	✦ Diaphragm Assembly	R160-82
9A	Diaphragm Nut	R150-10
9B	Diaphragm Plate	R150-14
9C	Diaphragm	R150-16
9D	O-Ring	R150-17
9E	Central Nut	R150-18
10	✦ O-Ring	R150-19
11	Body	R253-50
12	✦ Outlet Connection	See Chart 2
13	Outlet Stem	See Chart 2
14	✦ Outlet Nut	See Chart 2
15	✦ L.P. Gauge	See Chart 1
16	✦ H.P. Gauge	See Chart 1
17	Inlet Connection	See Chart 2
18	✦ Filter	R155M-56
19	✦ Retaining Ring	R155-120
20	✦ Inlet Nut	See Chart 2
21	Inlet Stem	See Chart 2
22	✦ Filter	R110-56
23	Relief Valve	See Chart 3
23A	Valve Body	R153F-70
23B	Seat	R140-71
23C	Seat Retainer	R140-72
23D	Upper Seat	R153F-73
23E	Disc	R140-74
23F	Spring	See Chart 3
23G	Cap	R153F-76
24	Pipe Plug	RP-4HP
25	Nozzle	R150-30
26	✦ Seat Assembly	See Chart 2
27	Valve Spring	R150-35
28	Gland	R110-36

---

Ref. No.	Part Description	Part No.
29	✦ Friction Washer	R110-37
30	✦ Gasket	R110-38
31	Cap Nut	R195-01
32	Adjusting Screw	R195-02
33	Housing Cap	R253-04
34	Spring Button	R240-06
35	Adjusting Spring	See Chart 1
36	✦ Diaphragm Assembly	R155T-82
36A	Diaphragm Plate	R253-14
36B	Diaphragm	R253-16
36C	O-Ring	R160-17
36D	Central Nut	R155T-18
37	✦ O-Ring	R253-19
38	✦ Washer	See Chart 2

---

Notice: Ref. No. 38 CO-6N for CGA320 only.

✦ Items most commonly required for regulator repair and recommended for stock.

Repair kits include these items.



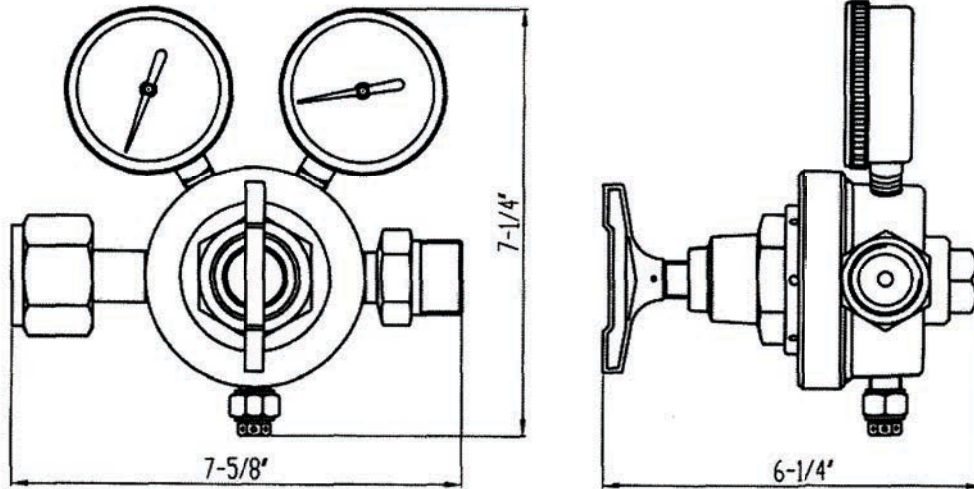

### MODEL INFORMATION

#### 155 SERIES

GAS SERVICE	MODEL NUMBER	MAX. DELIVERY PRESSURE (PSI)	INLET CONNECTION	OUTLET CONNECTION
L.P.G. GAS	155F-125	5-125	CGA510	7/8"-14LH(M)
OXYGEN	155X-125 155X-200	5-125 10-200	CGA540 CGA540	7/8"-14RH(M) 7/8"-14RH(M)
ACETYLENE	155Y-15 155Y-15-3	2-15 2-15	CGA510 CGA300	7/8"-14LH(M) 7/8"-14LH(M)
INERT GAS (Ar,HE,N2)	155IN-125 155IN-200	5-125 10-200	CGA580 CGA580	7/8"-14RH(M) 7/8"-14RH(M)
AIR	155Q-125 155Q-200	5-125 10-200	CGA346 CGA346	7/8"-14RH(M) 7/8"-14RH(M)
HYDROGEN METHANE	155H-200	10-200	CGA350	7/8"-14LH(M)

#### 155M SERIES

GAS SERVICE	MODEL NUMBER	MAX. DELIVERY PRESSURE (PSI)	INLET CONNECTION	OUTLET CONNECTION
OXYGEN INERT GAS AIR	155MIN-125 155MIN-200	5-125 10-200	1"-11 1/2NPS RH(M) 1"-11 1/2NPS RH(M)	1"-11 1/2NPS RH(F) 1"-11 1/2NPS RH(F)
ACETYLENE	155MY-15	2-15	1"-11 1/2NPS LH(M)	1"-11 1/2NPS LH(F)

### CHART 1

Description	155Y-15 155Y-15-3 155MY-15	155F-125	155X-200 155IN-200 155Q-200 155MIN-200	155X-125 155IN-125 155Q-125 155MIN-125	155H-200
Adjusting Spring	R150-07	R160-07	R155-07 R155-07A	R160-07	R155-07 R155-07A
H.P. Gauge	G25B-400	G25B-400	G25B-4000	G25B-4000	G25B-4000
L.P. Gauge	G25B-030RL	G25B-200	G25B-400	G25B-200	G25B-400
Housing Cap	R150-81	R150-81	R155-81B	R150-81	R155-81B
Relief Valve	N/A	N/A	R153N-87	R160-87	R152-87B

### CHART 2

#### Relief Valve

Description	155X-125 155IN-125 155MIN-125 155Q-125	155X-200 155IN-200 155Q-200 155MIN-200	155H-200
Relief Valve	R160-87	R153N-87	R152-87B
Valve Body	R140-70	R153F-70	/
Upper Seat	R140-73	R153F-73	/
Spring	R160-75	R153F-75	/
Cap	R140-76	R153F-76	/

### CHART 3

#### Cylinder Regulators

Gas Service	CGA INLET	Inlet Stem	Inlet Nut	Seat Assembly	Outlet Connection
Oxygen	540	R120-58	R120-57	R155-83	R155-108
LPG	510	R110-55	R110-54	R155-83A	R155-107
Acetylene	510	R110-55	R110-54	R155-83A	R155-107
	300	R110-58	806-1	R155-83A	R155-107
Inert Gas (Ar,He,N2)	580	R530-55	R190-54	R155-83	R155-108
	346	R120-58N	R120-57B	R155-83	R155-108
Hydrogen Methane	350	R152H-58	R152H-57	R155-83	R155-107

#### Manifold Regulators

Gas Service	Outlet Stem	Outlet Nut	Inlet Connection	Seat Assembly
Oxygen, Inert Gas Air	R155-103	R155-101	R155-110	R155-83
Acetylene	R155-103	R155-102	R155-110A	R155-83A

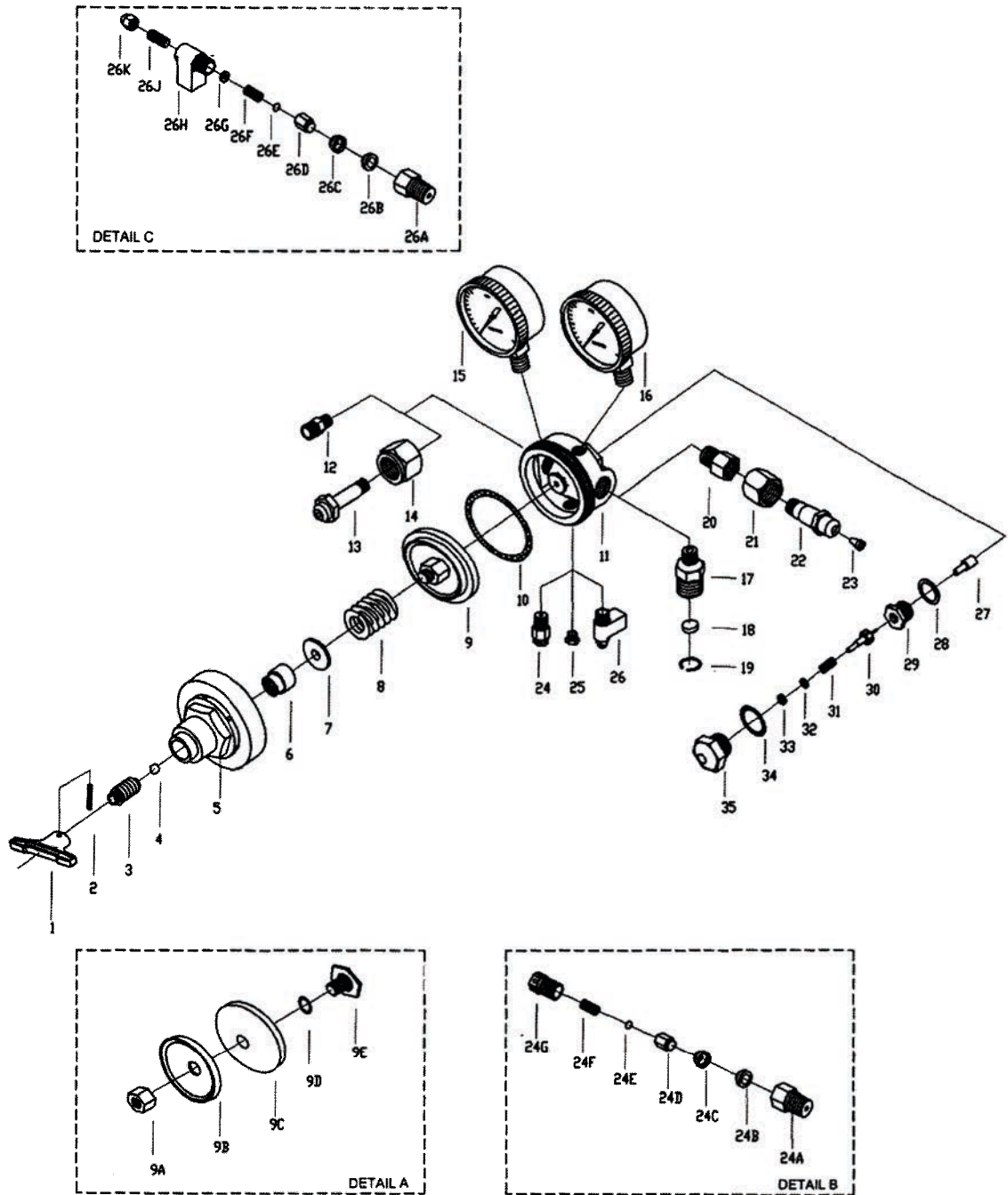

Ref. No.	Part Description	Part No.
1	Adjusting Knob	R150-01
2	Pin	R195-72
3	Adjusting Screw	R150-02
4	Steel Ball	R150-03
5	Housing Cap	See Chart 1
6	Cap Bushing	R150-05
7	Spring Button	R150-06
8	Adjusting Spring	See Chart 1
9	✦ Diaphragm Assembly	R160-82
9A	Diaphragm Nut	R150-10
9B	Diaphragm Plate	R150-14
9C	Diaphragm	R150-16
9D	O-Ring	R150-17
9E	Central Nut	R150-18
10	✦ O-Ring	R150-19
11	Body	R155-50
12	✦ Outlet Connection	See Chart 3
13	Outlet Stem	See Chart 3
14	✦ Outlet Nut	See Chart 3
15	✦ L.P. Gauge	See Chart 1
16	✦ H.P. Gauge	See Chart 1
17	Inlet Connection	See Chart 3
18	✦ Filter	R155M-56
19	✦ Retaining Ring	R155-120
20	Adapter	R155-64
21	✦ Inlet Nut	See Chart 3
22	Inlet Stem	See Chart 3
23	✦ Filter	R110-56
24	Relief Valve	See Chart 2
24A	Valve Body	See Chart 2
24B	Seat	R140-71
24C	Seat Retainer	R140-72
24D	Upper Seat	See Chart 2
24E	Disc	R140-74
24F	Spring	See Chart 2
24G	Cap	See Chart 2
25	Pipe Plug	RP-4HP
26	Vented Relief Valve	R152-87B
26A	Valve Body	R140-70
26B	Seat	R140-71
26C	Seat Retainer	R140-72

---

Ref. No.	Part Description	Part No.
26D	Upper Seat	R140-73
26E	Disc	R140-74
26F	Spring	R152-75B
26G	Spring Washer	R152-76
26H	Body	R152-77
26J	Screw	R195-02
26K	Cap Nut	R195-01
27	✦ Stem Extension	R155-28
28	✦ Gasket	R110-38
29	Nozzle	R155-30
30	✦ Seat Assembly	See Chart 3
31	Valve Spring	R110-35A
32	Gland	R110-36
33	✦ Friction Washer	R110-37
34	✦ O-Ring	R155-35
35	Back Plug	R155-36

---

✦ Items most commonly required for regulator repair and recommended for stock.  
Repair kits include these items.

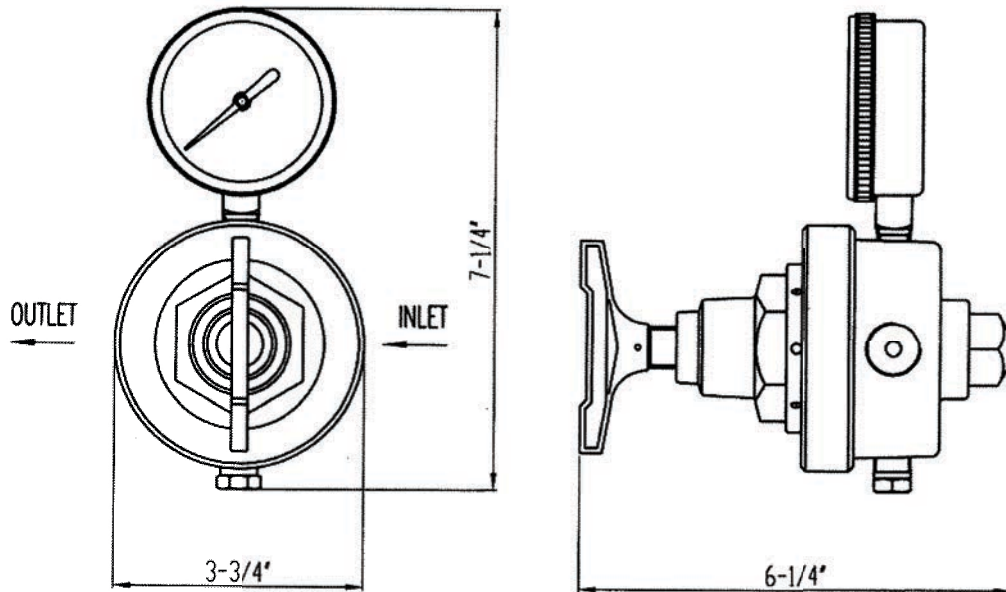

## MODEL INFORMATION

GAS SERVICE	MODEL NUMBER	MAX. DELIVERY PRESSURE (PSI)	INLET CONNECTION	OUTLET CONNECTION
L.P.G. GAS	155LF-125	5-125	3/4"NPT(F)	3/4"NPT(F)
	155LF-200	10-200	3/4"NPT(F)	3/4"NPT(F)
OXYGEN	155LX-80	4-80	3/4"NPT(F)	3/4"NPT(F)
	155LX-125	5-125	3/4"NPT(F)	3/4"NPT(F)
	155LX-200	10-200	3/4"NPT(F)	3/4"NPT(F)
ACETYLENE	155LY-15	2-15	3/4"NPT(F)	3/4"NPT(F)
INERT GAS	155LIN-125	5-125	3/4"NPT(F)	3/4"NPT(F)
CO2 AIR	155LIN-200	10-200	3/4"NPT(F)	3/4"NPT(F)

CHART 1

Description	155LY-15	155LX-80	155LX-200 155LIN-200 155LF-200	155LX-125 155LIN-125 152LF-125
Adjusting Spring	R153X-07	R160-07	R155-07 R155-07A	R160-07
L.P. Gauge	G25B-030RL	G25B-100	G25B-400	G25B-200
HousingCap	R150-81	R150-81	R155-81B	R150-81

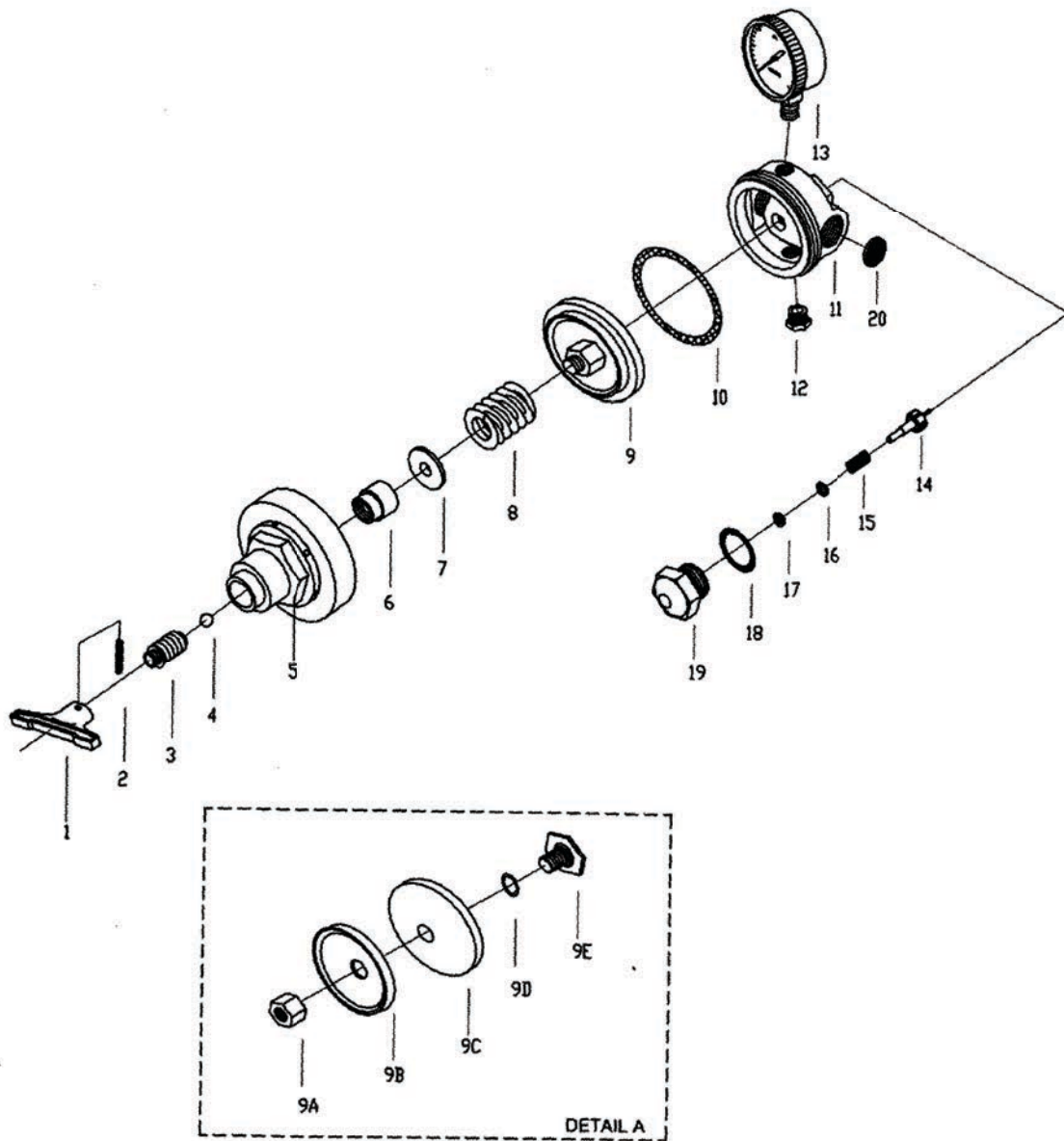

---

Ref. No.	Part Description	Part No.
1	Adjusting Knob	R150-01
2	Pin	R195-72
3	Adjusting Screw	R150-02
4	Steel Ball	R150-03
5	Housing Cap	See Chart 1
6	Cap Bushing	R150-05
7	Spring Button	R150-06
8	Adjusting Spring	See Chart 1
9	✦ Diaphragm Assembly	R160-82
9A	Diaphragm Nut	R150-10
9B	Diaphragm Plate	R150-14
9C	Diaphragm	R150-16
9D	O-Ring	R150-17
9E	Central Nut	R150-18
10	✦ O-Ring	R150-19
11	Body	R155L-50
12	Pipe Plug	RP-4HP
13	✦ L.P. Gauge	See Chart 1
14	✦ Seat Assembly	R155L-83
15	Valve Spring	R110-35A
16	Gland	R110-36
17	✦ Friction Washer	R110-37
18	✦ O-Ring	R155-35
19	Back Plug	R155-36
20	✦ Filter	R155-56A

---

✦ Items most commonly required for regulator repair and recommended for stock.  
Repair kits include these items.



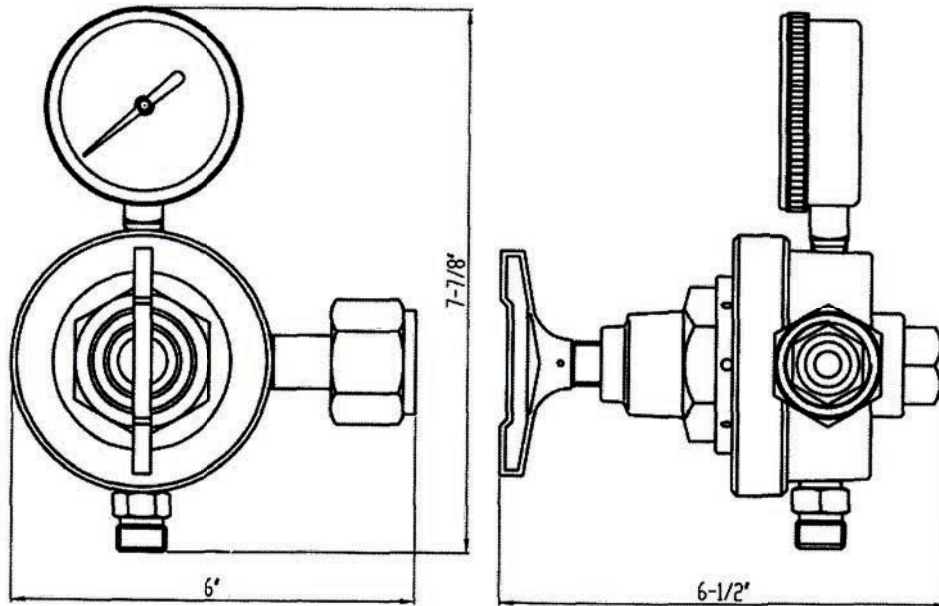

**MODEL INFORMATION**

GAS SERVICE	MODEL NUMBER	MAX. DELIVERY PRESSURE (PSI)	INLET CONNECTION	OUTLET CONNECTION
L.P.G. GAS	155SF-80	4-80	1"-11 1/2NPS LH(F)	7/8"-14LH(M)
OXYGEN	155SX-125	5-125	1"-11 1/2NPS RH(F)	7/8"-14RH(M)
ACETYLENE	155SY-15	2-15	1"-11 1/2NPS LH(F)	7/8"-14LH(M)

**CHART 1**

Description	155SY-15	155SX-125	155SF-80
Adjusting Spring	R153X-07	R160-07	R160-07
L.P. Gauge	G25B-030RL	G25B-200	G25B-100
Housing Cap	R150-81	R150-81	R150-81
Outlet Connection	R155-109A	R155-109	R155-109A
Inlet Nut	R155-102	R155-101	R155-102

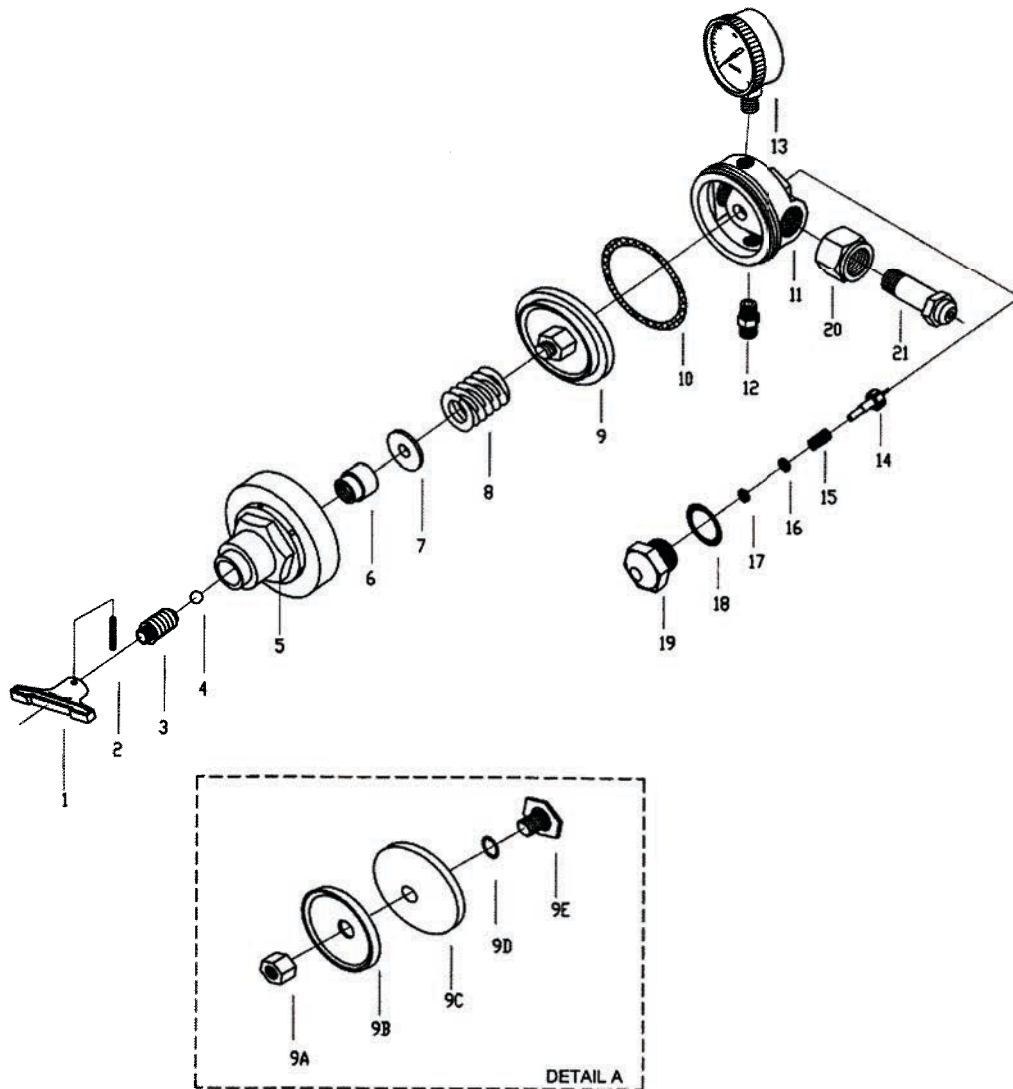

---

Ref. No.	Part Description	Part No.
1	Adjusting Knob	R150-01
2	Pin	R195-72
3	Adjusting Screw	R150-02
4	Steel Ball	R150-03
5	Housing Cap	See Chart 1
6	Cap Bushing	R150-05
7	Spring Button	R150-06
8	Adjusting Spring	See Chart 1
9	✦ Diaphragm Assembly	R160-82
9A	Diaphragm Nut	R150-10
9B	Diaphragm Plate	R150-14
9C	Diaphragm	R150-16
9D	O-Ring	R150-17
9E	Central Nut	R150-18
10	✦ O-Ring	R150-19
11	Body	R155S-50
12	✦ Outlet Connection	See Chart 1
13	✦ L.P. Gauge	See Chart 1
14	✦ Seat Assembly	R155L-83
15	Valve Spring	R110-35A
16	Gland	R110-36
17	✦ Friction Washer	R110-37
18	✦ O-Ring	R155-35
19	Back Plug	R155-36
20	✦ Inlet Nut	See Chart 1
21	Inlet Stem	R155-103

---

✦ Items most commonly required for regulator repair and recommended for stock.  
Repair kits include these items.

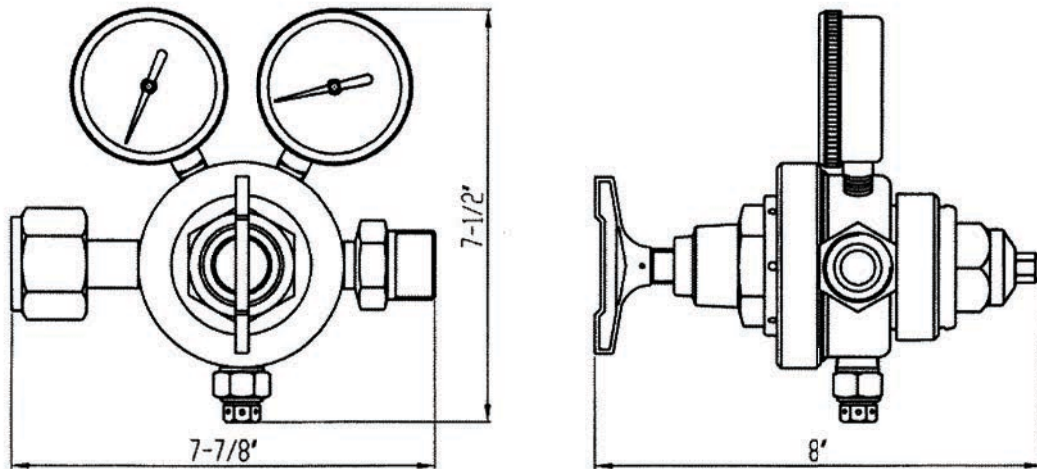

**MODEL INFORMATION**

**155T SERIES**

GAS SERVICE	MODEL NUMBER	MAX. DELIVERY PRESSURE (PSI)	INLET CONNECTION	OUTLET CONNECTION
L.P.G. GAS	155TF-125	5-125	CGA510	7/8"-14LH(M)
OXYGEN	155TX-125	5-125	CGA540	7/8"-14RH(M)
	155TX-200	10-200	CGA540	7/8"-14RH(M)
ACETYLENE	155TY-15	2-15	CGA510	7/8"-14LH(M)
	155TY-15-3	2-15	CGA300	7/8"-14LH(M)
INERT GAS (Ar,HE,N2)	155TIN-125	5-125	CGA580	7/8"-14RH(M)
	155TIN-200	10-200	CGA580	7/8"-14RH(M)
AIR	155TQ-125	5-125	CGA346	7/8"-14RH(M)
	155TQ-200	10-200	CGA346	7/8"-14RH(M)

**155TM SERIES**

GAS SERVICE	MODEL NUMBER	MAX. DELIVERY PRESSURE (PSI)	INLET CONNECTION	OUTLET CONNECTION
OXYGEN INERT GAS AIR	155TMIN-125	5-125	1"-11 1/2NPS RH(M)	1"-11 1/2NPS RH(F)
	155TMIN-200	10-200		
ACETYLENE	155TMY-15	2-15	1"-11 1/2NPS LH(M)	1"-11 1/2NPS LH(F)

CHART 1

Description	155TY-15 155TY-15-3 155TMY-15	155TF-125	155TX-250 155TIN-250 155TQ-200 155TC-200 155TH-200	155TX-125 155TIN-125 155TQ-125 155TMX-125
Adjusting Spring L.P	R150-07A	R160-07	R155-07 R155-07A	R160-07
Adjusting Spring H.P	R253Y-07	R652-07A	R652-07A	R652-07A
H.P. Gauge	G25B-400	G25B-400	G25B-4000	G25B-4000
L.P. Gauge	G25B-030R	G25B-200	G25B-400	G25B-200
Housing Cap	R150-81	R150-81	R155-81B	R150-81
Relief Valve	N/A	N/A	R153F-87	R153N-87

CHART 2

Cylinder Regulators

Gas Service	CGA INLET	Inlet Stem	Inlet Nut	H.P.Seat Assembly	L.P.Seat Assembly	Outlet Connection
Oxygen	540	R120-58	R120-57	R155T-83A	R155T-83	R155-108
LPG	510	R110-55	R110-54	R155T-83B	R155T-83	R155-107
Acetylene	510	R110-55	R110-54	R155T-83	R155T-83	R155-107
	300	R110-58	806-1	R155T-83	R155T-83	R155-107
Inert Gas (Ar,He,N2)	580	R110-55	R190-54	R155T-83	R155T-83	R155-108
Air	346	R120-58N	R120-57B	R155T-83	R155T-83	R155-108

Manifold Regulators

Gas Service	Outlet Stem	Outlet Nut	Inlet Connection	H.P.Seat Assembly	L.P.Seat Assembly
Oxygen, Inert Gas Air	R155-103	R155-101	R155-110	R155T-83A	R155T-83
Acetylene	R155-103	R155-102	R110-110A	R155T-83B	R155T-83

CHART 3

Relief Valve

Description	155TX-125 155TIN-125 155TQ-125 155TH-125 155TMX-125	155TX-250 155TIN-250 155TQ-200 155TC-200 155TH-200
Relief Valve	R153N-87	R153F-87
Spring	R153N-75	R153F-75

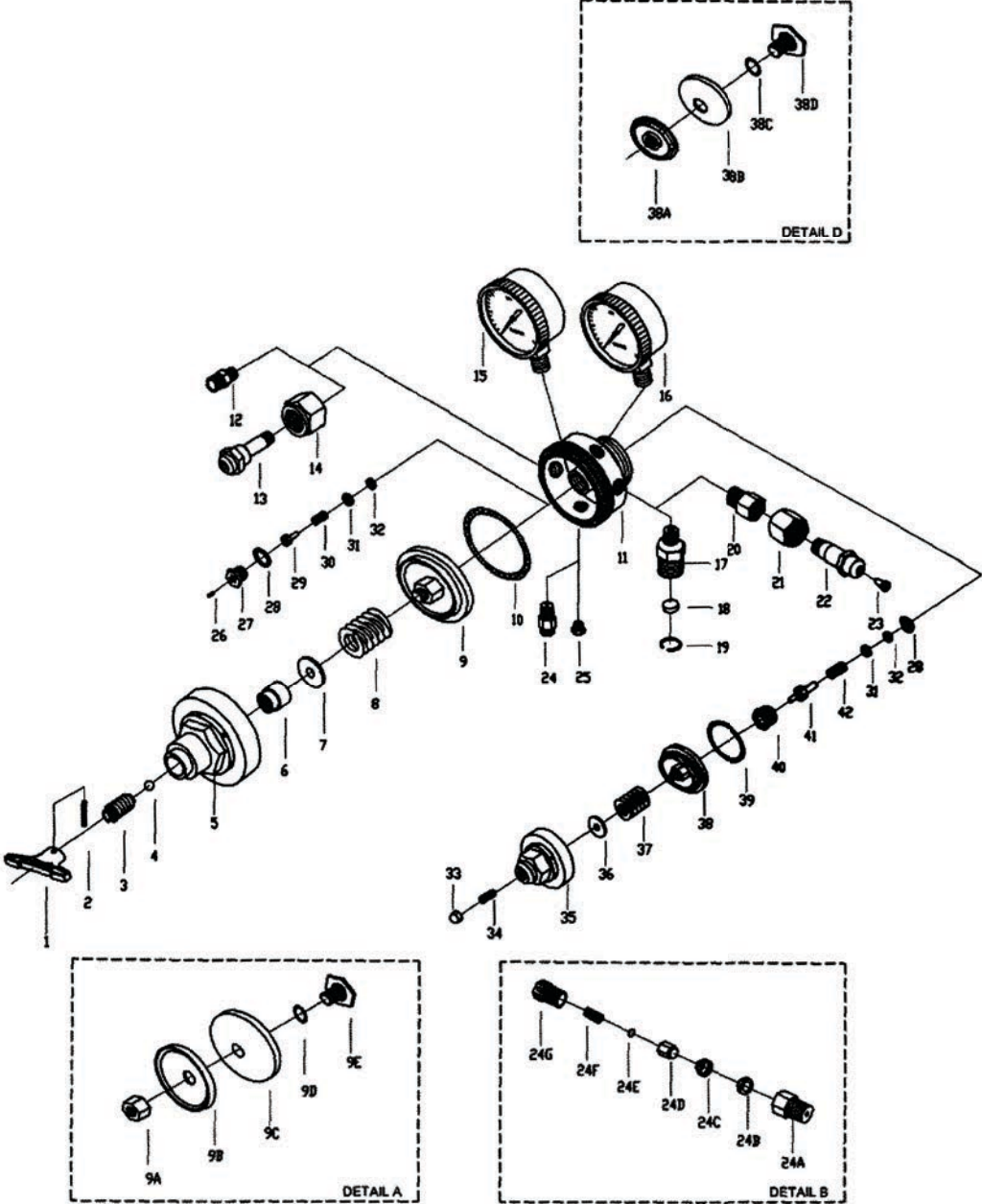

<b>Ref. No.</b>	<b>Part Description</b>	<b>Part No.</b>
1	Adjusting Knob	R150-01
2	Pin	R195-72
3	Adjusting Screw	R150-02
4	Steel Ball	R150-03
5	Housing Cap	See Chart 1
6	Cap Bushing	R150-05
7	Spring Button	R150-06
8	Adjusting Spring	See Chart 1
9	✦ Diaphragm Assembly	R160-82
9A	Diaphragm Nut	R150-10
9B	Diaphragm Plate	R150-14
9C	Diaphragm	R150-16
9D	O-Ring	R150-17
9E	Central Nut	R150-18
10	✦ O-Ring	R150-19
11	Body	R155T-50
12	✦ Outlet Connection	See Chart 2
13	Outlet Stem	See Chart 2
14	✦ Outlet Nut	See Chart 2
15	✦ L.P. Gauge	See Chart 1
16	✦ H.P. Gauge	See Chart 1
17	Inlet Connection	See Chart 2
18	✦ Filter	R155M-56
19	✦ Retaining Ring	R155-120
20	Adapter	R155-64
21	✦ Inlet Nut	See Chart 2
22	Inlet Stem	See Chart 2
23	✦ Filter	R110-56
24	Relief Valve	See Chart 3
24A	Valve Body	R153F-70
24B	Seat	R140-71
24C	Seat Retainer	R140-72
24D	Upper Seat	R153F-73
24E	Disc	R140-74
24F	Spring	See Chart 3
24G	Cap	R153F-76
25	Pipe Plug	RP-4HP
26	✦ Stem Extension	R155T-29
27	Nozzle	R155T-30
28	Gasket	R155T-28
29	✦ Seat Assembly	See Chart 2

---

Ref. No.	Part Description	Part No.
30	Valve Spring	R110-35
31	Gland	R110-36
32	✦ Friction Washer	R110-37
33	Cap Nut	R195-01
34	Adjusting Screw	R195-02
35	Housing Cap	R253-04
36	Spring Button	R240-06
37	Adjusting Spring	See Chart 1
38	✦ Diaphragm Assembly	R155T-82
38A	Diaphragm Plate	R253-14
38B	Diaphragm	R253-16
38C	O-Ring	R160-17
38D	Central Nut	R155T-18
39	✦ O-Ring	R253-19
40	Nozzle	R155T-30A
41	✦ Seat Assembly	See Chart 2
42	Valve Spring	R155-35

---

✦ Items most commonly required for regulator repair and recommended for stock.  
Repair kits include these items.



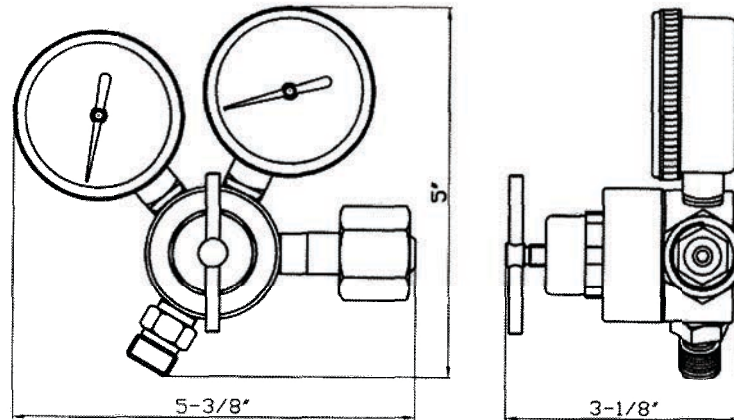

## MODEL INFORMATION

GAS SERVICE	MODEL NUMBER	MAX. DELIVERY PRESSURE (PSI)	INLET CONNECTION	OUTLET CONNECTION
L.P.G. GAS	190F-80	4-80	CGA510	9/16"-18LH(M)
OXYGEN	190X-80	4-80	CGA540	9/16"-18RH(M)
ACETYLENE	190Y-15	2-15	CGA510	9/16"-18LH(M)
	190Y-15-3	2-15	CGA300	9/16"-18LH(M)
	190Y-15-5	2-15	CGA520	9/16"-18LH(M)
INERT GAS (Ar,He,N2)	190IN-80	4-80	CGA580	5/8"-18RH(F)
	190IN-175	5-175	CGA580	5/8"-18RH(F)
	190IN-175-F	5-175	CGA580	1/4" SAME Flare
CARBON DIOXIDE	190C-175	5-175	CGA320	5/8"-18RH(F)
	190C-175-F	5-175	CGA320	1/4" SAME Flare
	190CD-45	0-45 (SCFH)	CGA320	5/8"-18RH(F)
ARGON (Ar/CO2)	190AR1-50-B	0-50 (SCFH)	CGA580	3/16" Barb
	190AR1-50-P	0-50 (SCFH)	CGA580	5/32" Push-in-Tube
	190AR-50	0-50 (SCFH)	CGA580	5/8"-18RH(F)
	190AR-50-B	0-50 (SCFH)	CGA580	3/16" Barb
	190AR-50-P	0-50 (SCFH)	CGA580	5/32" Push-in-Tube

CHART 1

Description	190Y-15 190Y-15-3 190Y-15-5	190F-80	190X-80 190IN-80	190IN-175 190IN-175-F 190C-175 190C-175-F
Adjusting Spring	R110-07	R120-07	R120-07	R190N-07
H.P. Gauge	G20-400	G20-400	G20-4000	G20-4000
L.P. Gauge	G20-030R	G20-100	G20-100	G20-300
Adjusting Knob	R190-02	R190-02	R190-02	R190-02
Body	R190-50	R190-50	R190-50	G20-300
Description	190AR1-50-B 190AR1-50-P	190AR-50 190AR-50-B 190AR-50-P	190CD-45	
Adjusting Spring	R120-07	R120-07	R120-07	
H.P. Gauge	N/A	G20-4000	G20-4000	
L.P. Gauge	G20-050CF	G20-050CF	G20-D050CF	
Adjusting Knob	R190-01	R190-01	R190-01	
Body	R190-50-1	R190-50	R190-50	

CHART 2

Diaphragm Assembly

Description	190F-80 190Y-15 190Y-15-3 190Y-15-5	190X-80 190IN-80 190AR1-50-B 190AR1-50-P 190AR-50 190AR-50-B 190AR-50-P 190CD-45	190IN-175 190IN-175-F 190C-175 190C-175-F
Diaphragm Assembly	R110-82A	R120-82	R120-82A

CHART 3

Gas Service	CGA INLET	Inlet Stem	Inlet Nut	Nozzle	Seat Assembly	Outlet Connection
Oxygen	540	R120-58	R120-57	R120-30	R120-83	R120-53
LPG	510	R110-55	R110-54	R110-30	R110-83	R110-53
Acetylene	510	R110-55	R110-54	R110-30	R110-83	R110-53
	300	R110-58	806-1	R110-30	R110-83	R110-53
	520	R210Y1-55B	319-2	R110-30	R110-83	R110-53
Inert Gas (Ar,He,N2)	580	RNP15-3SF	R190-54	R110-30	R120-83	R195-52
	580	RNP15-3SF	R190-54	R110-30	R120-83	R195-52
	580	RNP15-3SF	R190-54	R110-30	R120-83	ROB48F
Carbon Dioxide	320	RNP15-3SF	806-1	R110-30	R120-83	R195-52
	320	RNP15-3SF	806-1	R110-30	R120-83	ROB48F
	320	CO-3	806-1	R110-30	R120-83	R190-52
ARGON (Ar/CO2)	580	R110-55	R190-54	R110-30	R120-83	ROB316
	580	R110-55	R190-54	R110-30	R120-83	ROB532
	580	R110-55	R190-54	R110-30	R120-83	R190-52
	580	R110-55	R190-54	R110-30	R120-83	ROB316
	580	R110-55	R190-54	R110-30	R120-83	ROB532

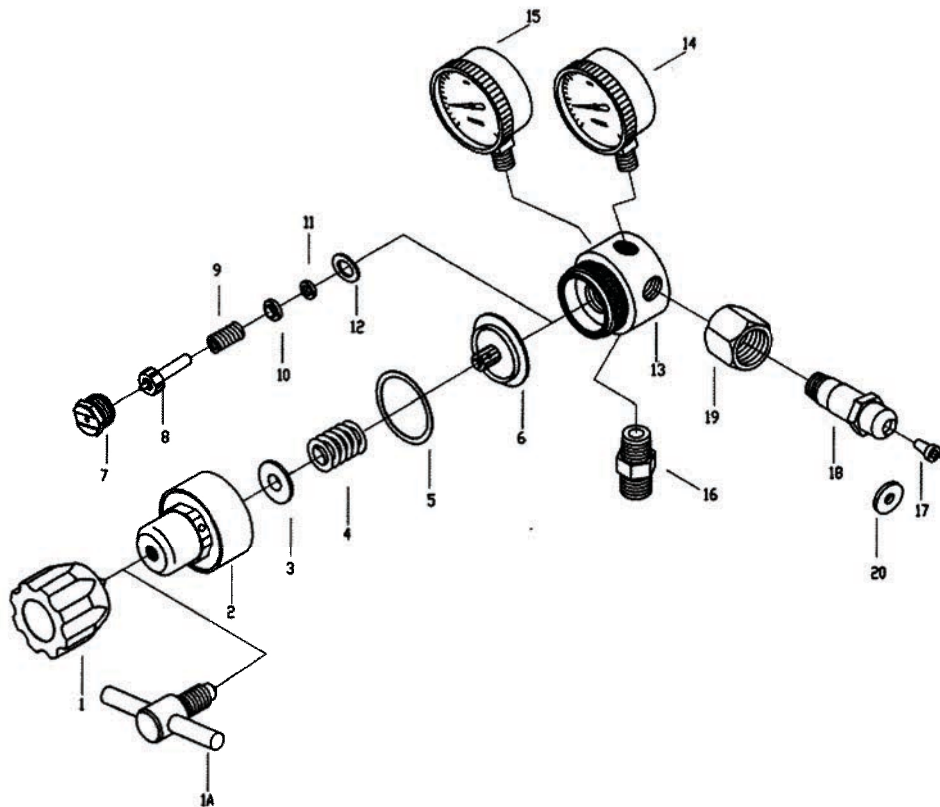

---

Ref. No.	Part Description	Part No.
1	Adjusting Knob	See Chart 1
1A	Adjusting Knob	See Chart 1
2	Housing Cap	R190-04
3	Spring Button	R110-06
4	Adjusting Spring	See Chart 1
5	Slip Ring	R110-08
6	✦ Diaphragm Assembly	See Chart 2
7	Nozzle	See Chart 3
8	✦ Seat Assembly	See Chart 3
9	Valve Spring	R110-35
10	Gland	R110-36
11	✦ Friction Washer	R110-37
12	✦ Gasket	R110-38
13	Body	See Chart 1
14	✦ H.P. Gauge	See Chart 1
15	✦ L.P. Gauge	See Chart 1
16	✦ Outlet Connection	See Chart 3
17	✦ Filter	R110-56
18	Inlet Stem	See Chart 3
19	✦ Inlet Nut	See Chart 3
20	✦ Washer	RNPCO6N

---

Notice: Ref. No.20 RNPCO6N for CGA320 only.

✦ Items most commonly required for regulator repair and recommended for stock.

Repair kits include these items.

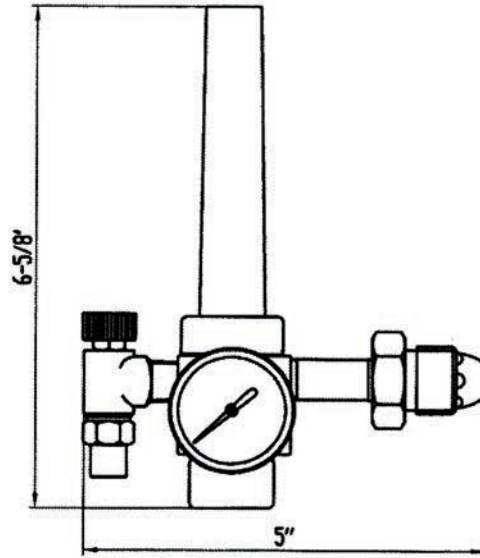

**MODEL INFORMATION**

GAS SERVICE	MODEL NUMBER	FLOWMETER (SCFH)	INLET CONNECTION	OUTLET CONNECTION
ARGON	191AR-60	60	CGA580	5/8"-18RH(F)
HELIUM	191HE-150	150	CGA580	5/8"-18RH(F)
CARBON DIOXIDE	191CD-60	60	CGA320	5/8"-18RH(F)
NITROGEN	191NR-70	70	CGA580	5/8"-18RH(F)
AIR	191QR-70	70	CGA590	5/8"-18RH(F)

**CHART 1**

Description	191AR-60 191CD-60	191NR-70 191QR-70	191HE-150
Relief Valve	R195-66	R195-66UA	R195-66UB

**CHART 2**

Gas Service	MODEL No.	CGA INLET	Inlet Stem	Inlet Nut
ARGON	191AR	580	R110-55	R190-54
HELIUM	191HE-150	580	R110-55	R190-54
CARBON DIOXIDE	191CD-60	320	CO-3	806-1
NITROGEN	191NR-70	580	R110-55	R190-54
AIR	191QR-70	590	R110-55	R110-57B

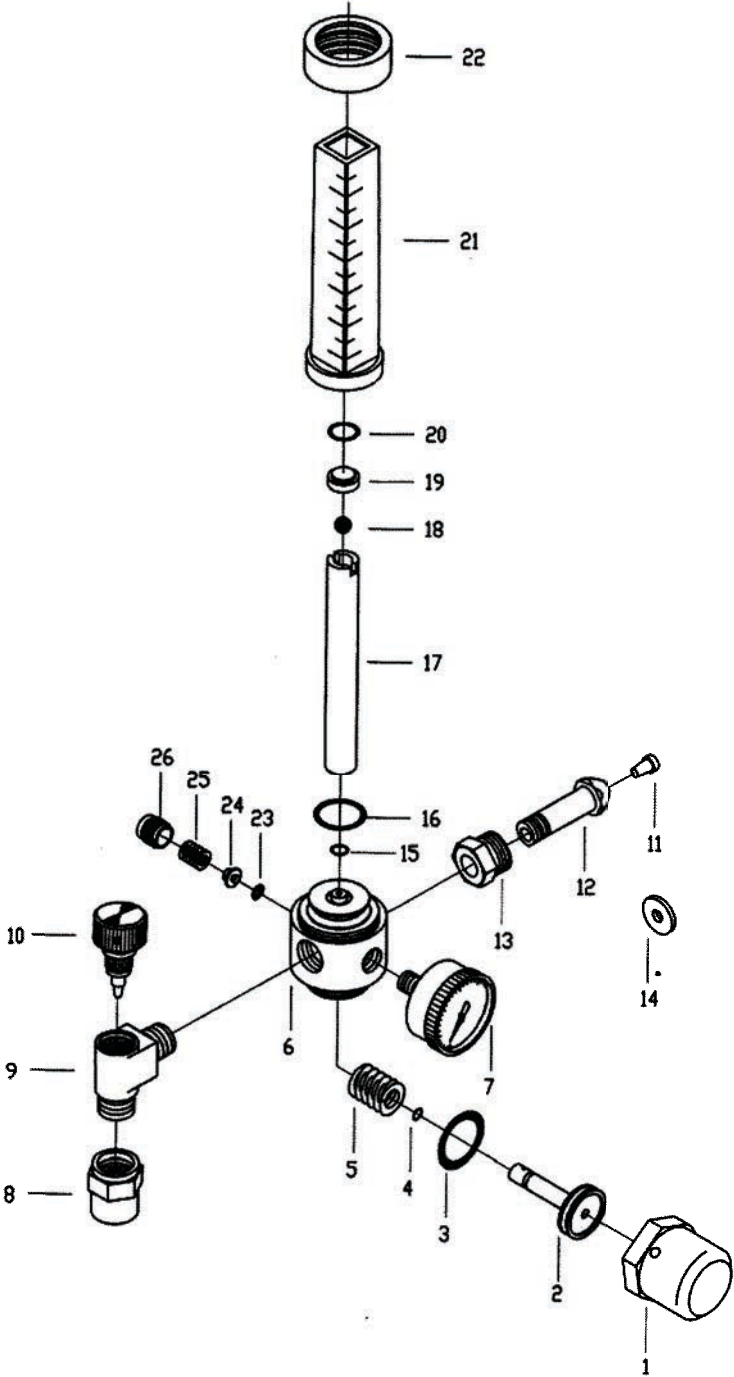

Ref. No.	Part Description	Part No.
1	Cap	R191-04
2	Seat Holder	R230-58
3	✦ O-Ring	R230-54
4	✦ O-Ring	R230-60
5	Adjusting Spring	R191-52
6	Body	R191-50
7	✦ H.P Gauge	GR15-4000G
8	✦ Nut	R194-52A
9	Elbow	R195-53
10	✦ Needle Valve Assembly	R195-93A
11	✦ Filter	R110-56
12	Inlet Stem	See Chart 2
13	✦ Inlet Nut	See Chart 2
14	✦ Washer	CO-6N
15	✦ O-Ring Small	R195-61A
16	✦ O-Ring Large	R195-60
17	✦ Tube	R195-62
18	✦ Ball Float	T130-30
19	✦ Washer	R195-73
20	✦ O-Ring	Y4903
21	✦ Hood	See Chart 1
22	FM Body Bushing	R191-67
23	✦ O-Ring	R120-13
24	O-Ring Holder	R120-12
25	Spring	R190N-35
26	Adjusting Nut	R191-10

Notice: Ref. No.14 CO-6N for CGA320 only.

✦ Items most commonly required for regulator repair and recommended for stock.

Repair kits include these items.

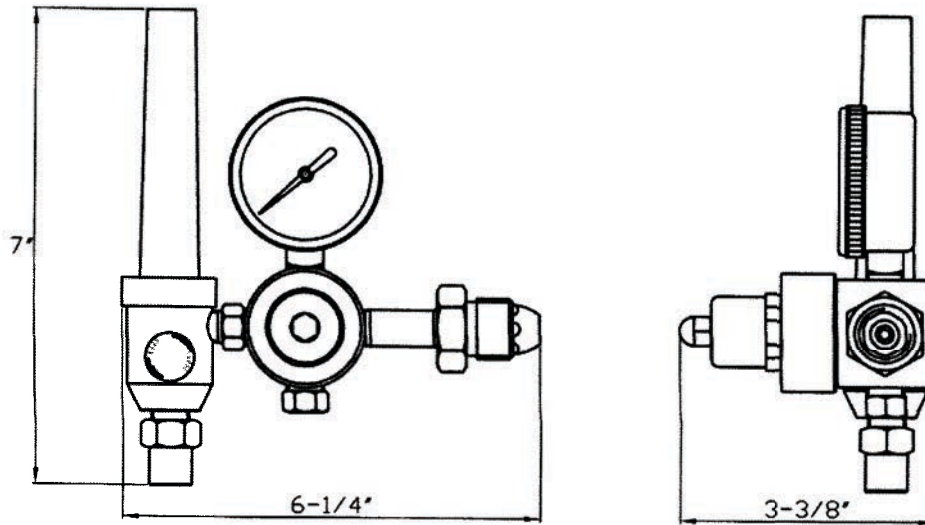

## MODEL INFORMATION

GAS SERVICE	MODEL NUMBER	FLOWMETER (SCFH)	INLET CONNECTION	OUTLET CONNECTION
ARGON	195AR-60	60	CGA580	5/8"-18RH(F)
	195AR-60-680	60	CGA680	5/8"-18RH(F)
HELIUM	195HE-150	150	CGA580	5/8"-18RH(F)
CARBON DIOXIDE	195CD-60	60	CGA320	5/8"-18RH(F)

CHART 1

Gas Service	CGA INLET	Inlet Stem	Inlet Nut	HOOD	Body	Nozzle	Seat Assembly	Gauge
ARGON	580	R110-55	R190-54	R195-66	R195-50	R110-30	R120-83	G20-4000
	680	R550-58C	R550-57C	R195-66	R195AR-50	SR4-30	SR4-83	G20-6000
HELIUM	580	R110-55	R190-54	R195-66UB	R195-50	R110-30	R120-83	G20-4000
CARBON DIOXIDE	320	CO-3	806-1	R195-66	R195-50	R110-30	R120-83	G20-4000

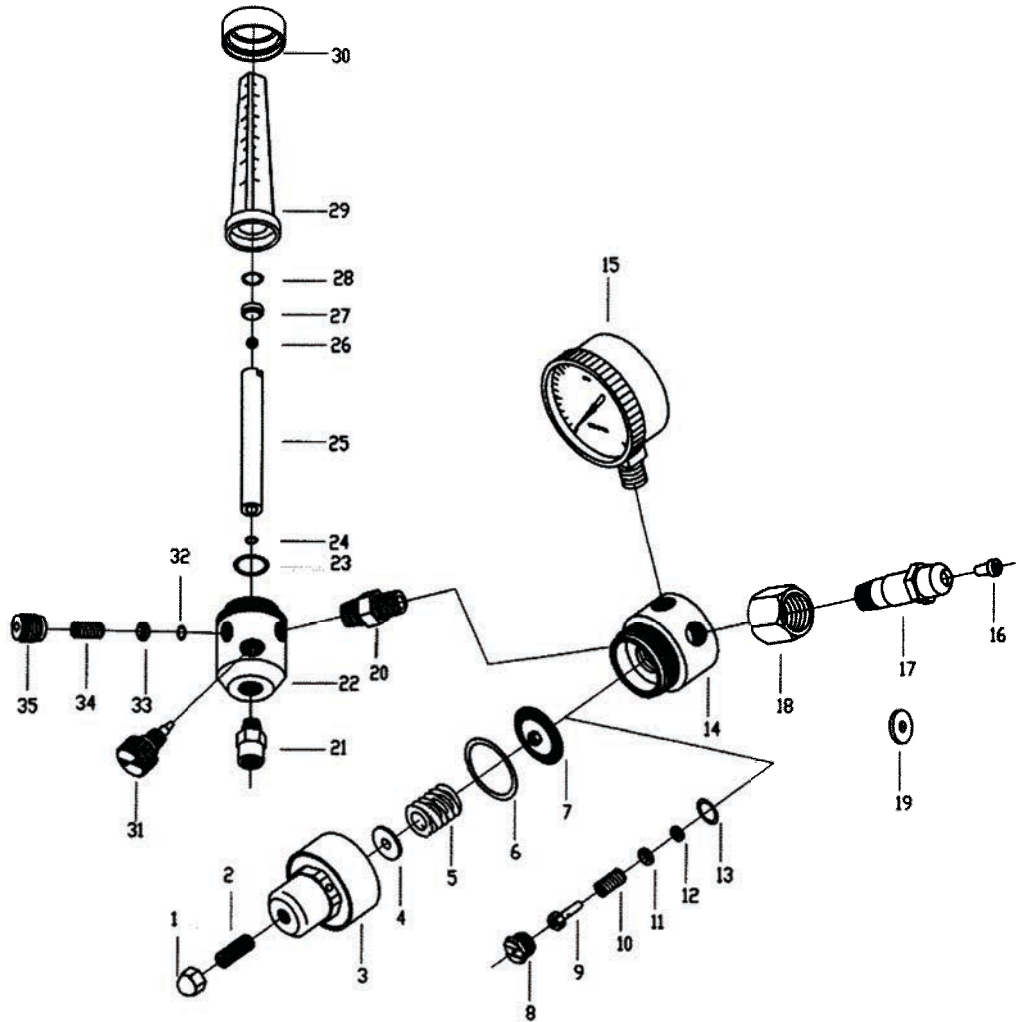



Ref. No.	Part Description	Part No.
1	Cap	R195-01P
2	Adjusting Screw	R195-02
3	Housing Cap	R190-04
4	Spring Button	R110-06
5	L.P Adjusting Spring	R120-07
6	Slip Ring	R110-08
7	✦ Diaphragm Assembly	R120-82
8	Nozzle	See Chart 1
9	✦ Seat Assembly	See Chart 1
10	Valve Spring	R110-35
11	Gland	R110-36
12	✦ Friction Washer	R110-37
13	✦ Gasket	R110-38
14	Body	See Chart 1
15	✦ H.P. Gauge	See Chart 1
16	✦ Filter	R110-56
17	Inlet Stem	See Chart 1
18	✦ Inlet Nut	See Chart 1
19	✦ Washer	CO-6N
20	Flowmeter Inlet	R195-51
21	Outlet Connection	R195-52
22	Flowmeter Body	R195-59D
23	✦ O-Ring Large	R195-60
24	✦ O-Ring Small	R195-61
25	✦ Tube	R195-62
26	✦ Ball Float	T130-30
27	✦ Washer	R195-73
28	✦ O-Ring	Y4903
29	✦ Hood	See Chart 1
30	FM Body Bushing	R195-67
31	✦ Needle Valve Assembly	R195-93A
32	✦ O-Ring	R120-13
33	O-Ring Holder	R120-12
34	Spring	R190N-35
35	Adjusting Nut	R191-10

Notice: Ref. No.19 CO-6N for CGA320 only.

✦ Items most commonly required for regulator repair and recommended for stock.

Repair kits include these items.

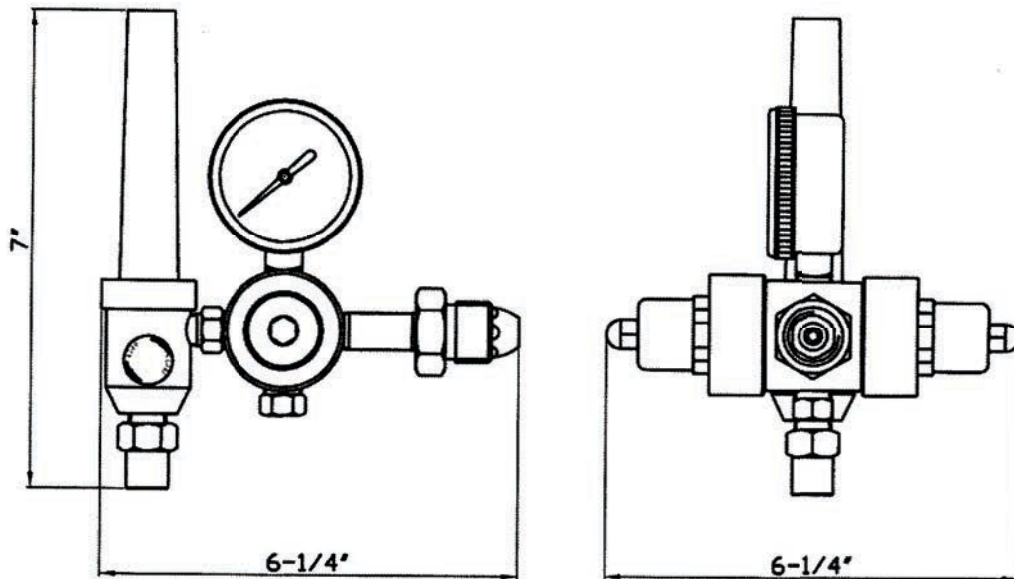

**MODEL INFORMATION**

GAS SERVICE	MODEL NUMBER	FLOWMETER (SCFH)	INLET CONNECTION	OUTLET CONNECTION
ARGON	195TAR-60	60	CGA580	5/8"-18RH(F)
HELIUM	195THE-150	150	CGA580	5/8"-18RH(F)
CARBON DIOXIDE	195TCD-60	60	CGA320	5/8"-18RH(F)

**CHART 1**

Gas Service	CGA INLET	Inlet Stem	Inlet Nut	HOOD
ARGON	580	R110-55P	R190-54P	R195-66
HELIUM	580	R110-55P	R190-54P	R195-66UB
CARBON DIOXIDE	320	CO-3P	806-1P	R195-66

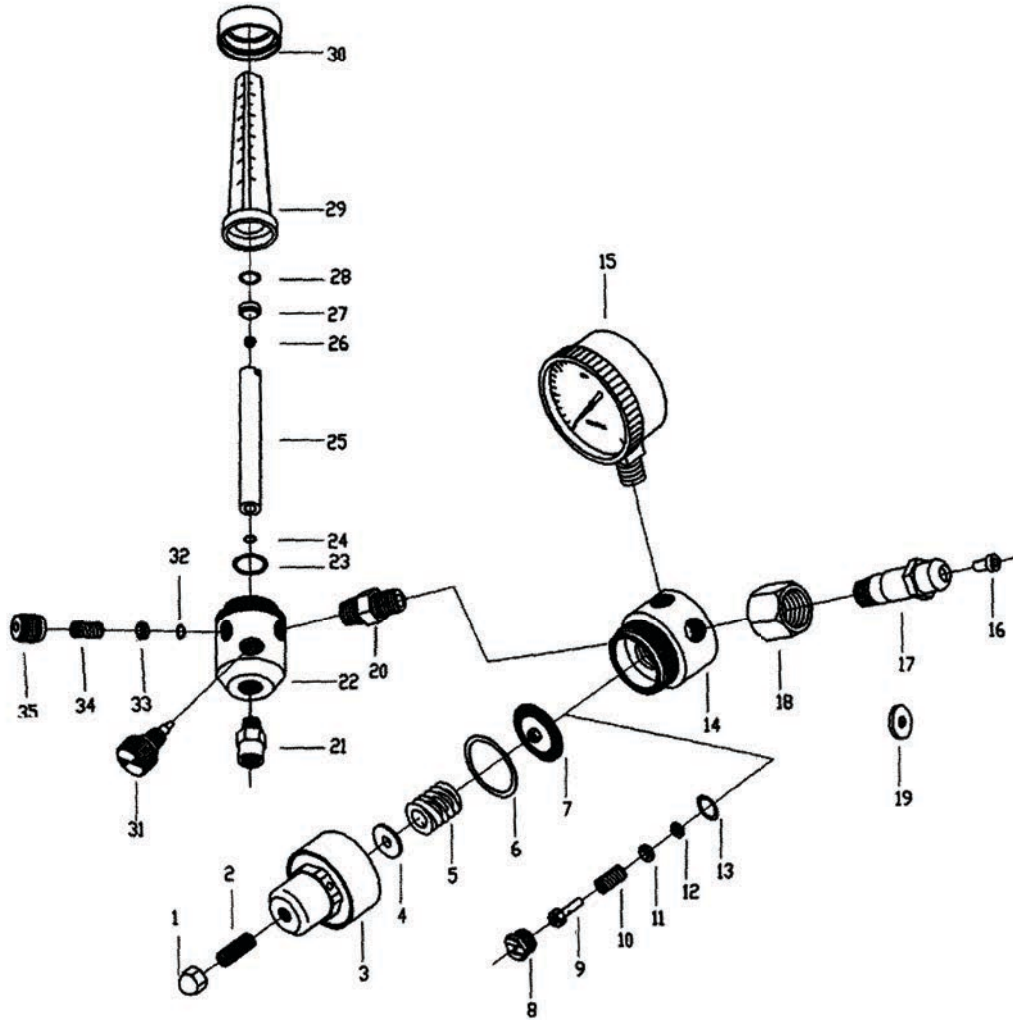

Ref. No.	Part Description	Part No.
1	Cap	R195-01P
2	Adjusting Screw	R195-02
3	Housing Cap	R190-04
4	Spring Button	R110-06
5	L.P Adjusting Spring	R120-07
6	Slip Ring	R110-08
7	✦ Diaphragm Assembly	R120-82F
8	Nozzle	R110-30
9	✦ Seat Assembly	R120-83B
10	Valve Spring	R150-35
11	Gland	R110-36
12	✦ Friction Washer	R110-37
13	✦ Gasket	R110-38
14	Body	R250-50P
15	✦ H.P. Gauge	G20P-4000
16	✦ Filter	R110-56
17	Inlet Stem	See Chart 1
18	✦ Inlet Nut	See Chart 1
19	✦ Washer	CO-6N
20	Flowmeter Inlet	R195-51P
21	Outlet Connection	R195-52P
22	Flowmeter Body	R195-59DP
23	✦ O-Ring Large	R195-60
24	✦ O-Ring Small	R195-61
25	✦ Tube	R195-62
26	✦ Ball Float	T130-30
27	✦ Washer	R195-73
28	✦ O-Ring	Y4903
29	✦ Hood	See Chart 1
30	FM Body Bushing	R195-67P
31	✦ Needle Valve Assembly	R195-93AP
32	✦ O-Ring	R120-13
33	O-Ring Holder	R120-12
34	Spring	R190N-35
35	Adjusting Nut	R191-10P
36	H.P Adjusting Spring	R190N-07
37	Plug	RP-4HPP
38	✦ Diaphragm Assembly	R120-82E

Notice: Ref. No.19 CO-6N for CGA320 only.

✦ Items most commonly required for regulator repair and recommended for stock.

Repair kits include these items.

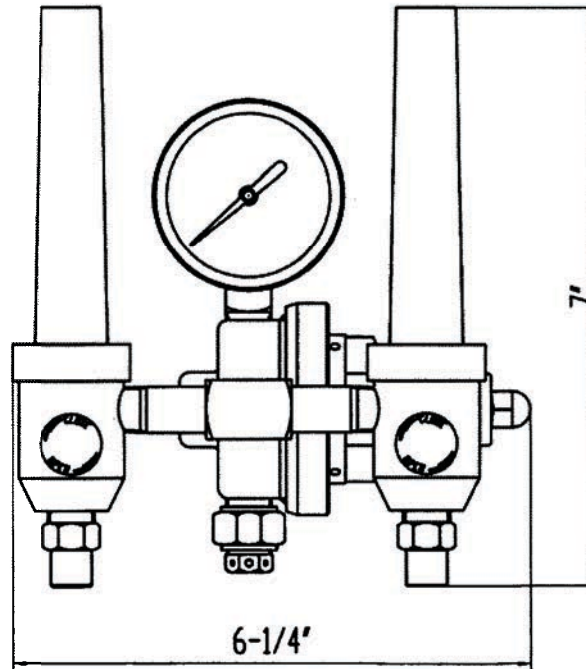

**MODEL INFORMATION**

GAS SERVICE	MODEL NUMBER	MAX.DELIVERY PRESSER(PSI)	INLET CONNECTION	OUTLET CONNECTION
ARGON	196AR-60	0-60(SCFH)	CGA580	5/8"-18RH(F)
HELIUM	196HE-150	0-150(SCFH)	CGA580	5/8"-18RH(F)

**CHART 1**

Gas Service	CGA INLET	Inlet Stem	Inlet Nut	HOOD
ARGON	580	R110-55	R190-54	R195-66
HELIUM	580	R110-55	R190-54	R195-66UB

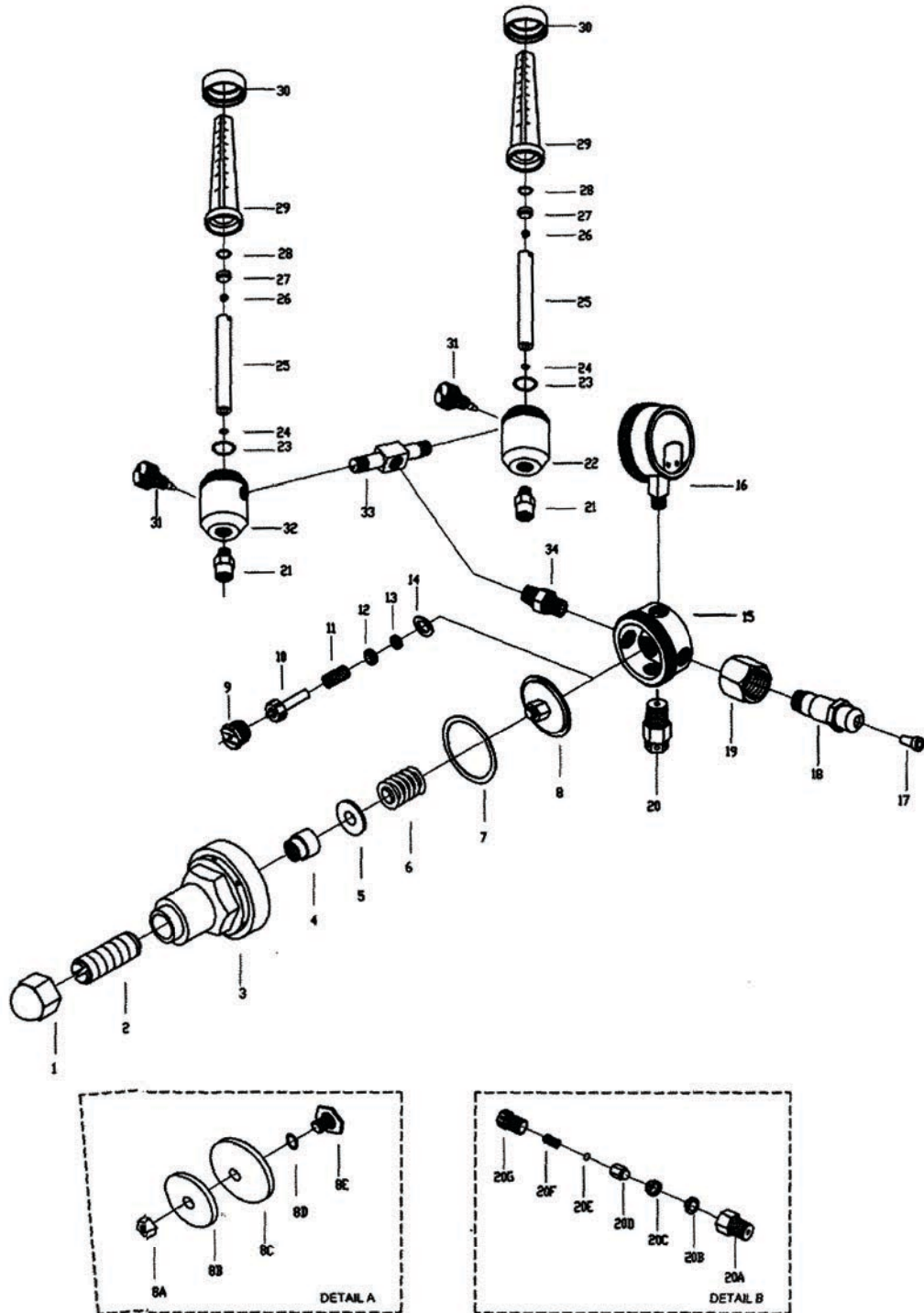

Ref. No.	Part Description	Part No.
1	Cap	R198-01
2	Adjusting Screw	R198-02
3	Housing Cap	R130-04
4	Cap Bushing	R130-05
5	Spring Button	R130-06
6	Adjusting Spring	R140-07
7	Slip Ring	R130-08
8	✦ Diaphragm Assembly	R130-82A
8A	Diaphragm Nut	R240-10
8B	Diaphragm Plate	R130-14
8C	Seal Washer	R130-15
8D	Diaphragm	R130-16D
8E	Centralizer	R130-18
9	Nozzle	R110-30
10	✦ Seat Assembly	R120-83
11	Valve Spring	R110-35
12	Gland	R110-36
13	✦ Friction Washer	R110-37
14	✦ Gasket	R110-38
15	Body	R140-50B
16	✦ H.P. Gauge	G20-4000
17	✦ Filter	R110-56
18	Inlet Stem	See Chart 1
19	✦ Inlet Nut	See Chart 1
20	Relief Valve	R140-87
20A	Valve Body	R140-70
20B	Seat	R140-71
20C	Seat Retainer	R140-72
20D	Upper Seat	R140-73
20E	Disc	R140-74
20F	Spring	R140-75
20G	Cap	R140-76
21	✦ Outlet Connection	R195-52
22	Flowmeter Body	R195-59C
23	✦ O-Ring Large	R195-60
24	✦ O-Ring Small	R195-61
25	✦ Tube	R195-62
26	✦ Ball Float	T130-30
27	✦ Washer	R195-73
28	✦ O-Ring	Y4903
29	✦ Hood	See Chart 1

---

Ref. No.	Part Description	Part No.
30	FM Body Bushing	R195-67
31	✦ Needle Valve Assembly	R195-93B
32	Flowmeter Body	R195-59A
33	Flowmeter Inlet	R195-51B
34	Flowmeter Inlet	R195-51

---

✦ Items most commonly required for regulator repair and recommended for stock.

Repair kits include these items.



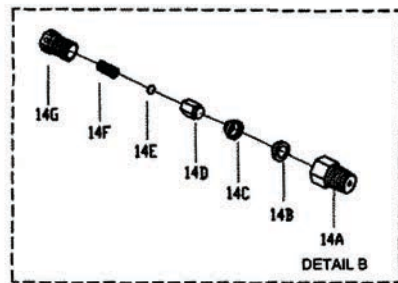
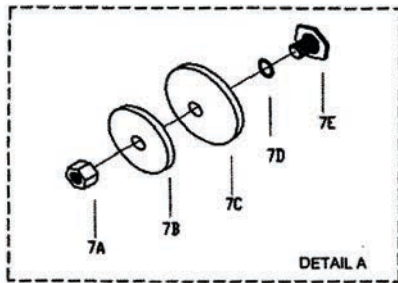
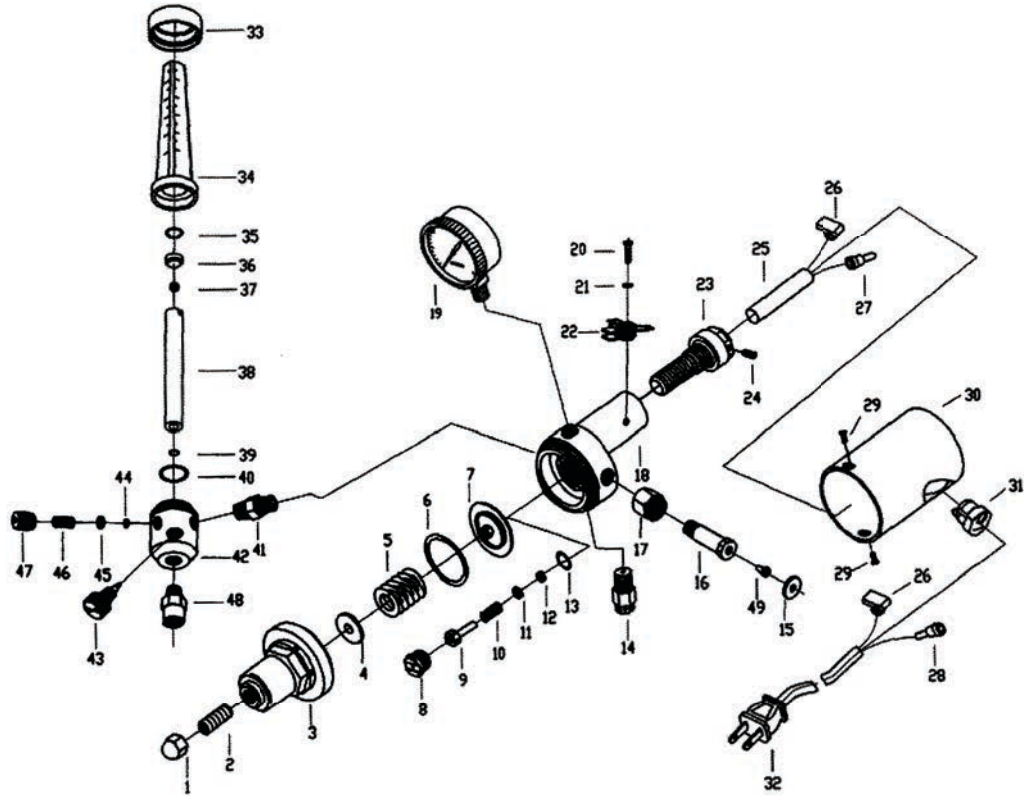

Ref. No.	Part Description	Part No.
1	Cap	R198-01
2	Adjusting Screw	R198-02
3	Housing Cap	R130-04
4	Spring Button	R130-06
5	Adjusting Spring	R140-07
6	Slip Ring	R130-08
7	✦ Diaphragm Assembly	R130-82A
7A	Diaphragm Nut	R240-10
7B	Diaphragm Plate	R130-14
7C	Seal Washer	R130-15
7D	Diaphragm	R130-16D
7E	Centralizer	R130-18
8	Nozzle	R110-30
9	✦ Seat Assembly	R120-83
10	Valve Spring	R110-35
11	Gland	R110-36
12	✦ Friction Washer	R110-37
13	✦ Gasket	R110-38
14	Relief Valve	R140-87
14A	Valve Body	R140-70
14B	Seat	R140-71
14C	Seat Retainer	R140-72
14D	Upper Seat	R140-73
14E	Disc	R140-74
14F	Spring	R140-75
14G	Cap	R140-76
15	✦ Washer	CO-6N
16	Inlet Stem	CO-3
17	✦ Inlet Nut	806-1
18	Body	R198-50
19	✦ H.P. Gauge	G20B-4000
20	Set Screw	R198-89
21	✦ Washer	R198-86
22	✦ Thermostat	R198-90
23	Heater Holder	R198-92
24	Set Screw	R198-93
25	✦ Heater	R197-94(110V)
26	✦ End Joint	R198-84
27	✦ End Joint	R198-82
28	✦ End Joint	R198-80
29	Screw	R198-16

---

Ref. No.	Part Description	Part No.
30	✦ Cap	R198-96
31	✦ Locking Plug	R198-98
32	✦ Electric Wire	R198-102
33	FM Body Bushing	R195-67
34	✦ Hood	R195-66
35	✦ O-Ring	Y4903
36	✦ Washer	R195-73
37	✦ Ball Float	T130-30
38	✦ Tube	R195-62
39	✦ O-Ring Small	R195-61
40	✦ O-Ring Large	R195-60
41	Flowmeter Inlet	R195-51
42	Flowmeter Body	R195-59D
43	✦ Needle Valve Assembly	R195-93A
44	✦ O-Ring	R120-13
45	✦ O-Ring Holder	R120-12
46	Spring	R190N-35
47	Adjusting Nut	R191-10
48	✦ Outlet Connection	R195-52
49	✦ Filter	R110-56

---

✦ Items most commonly required for regulator repair and recommended for stock.  
Repair kits include these items.

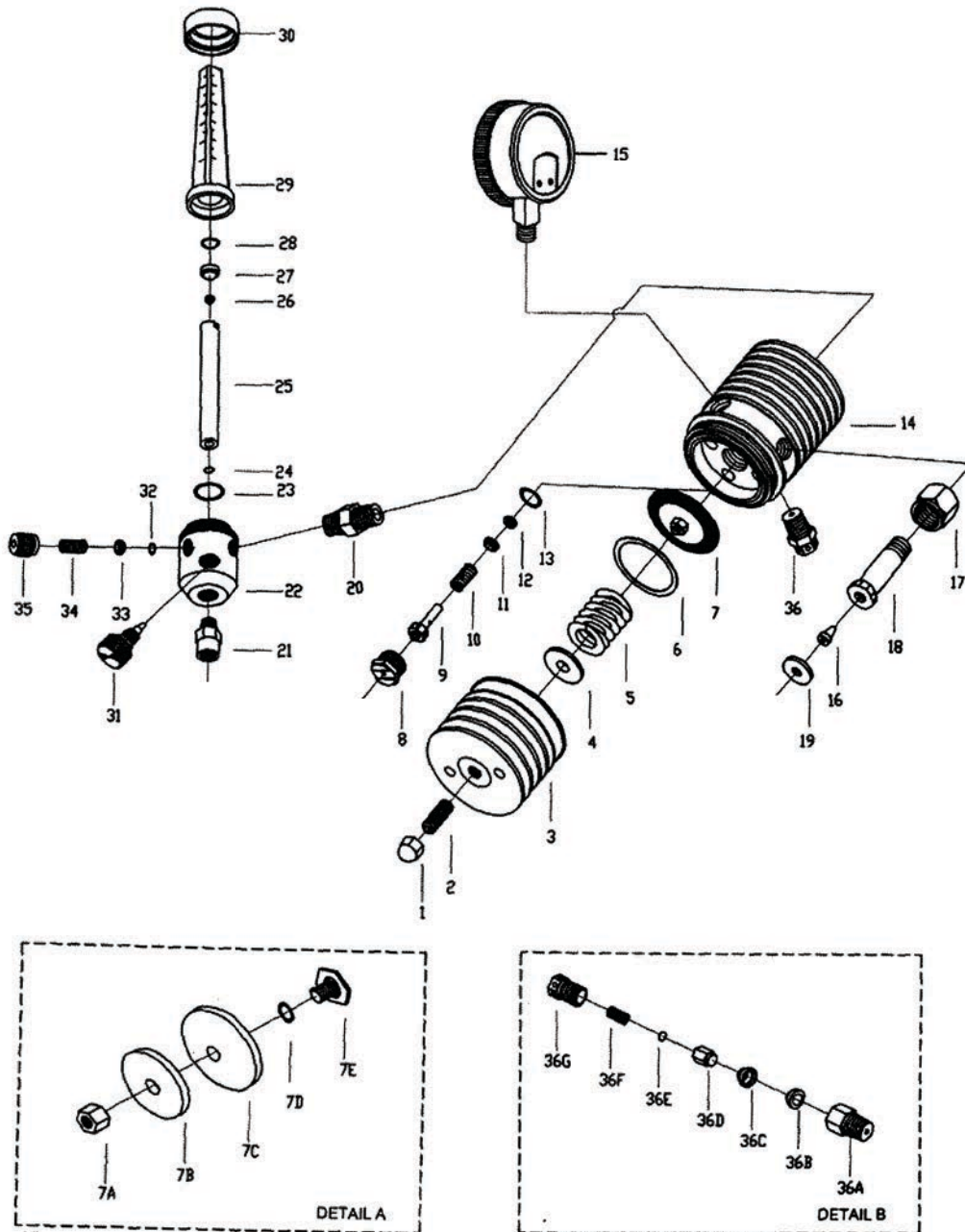

Ref. No.	Part Description	Part No.
1	Cap	R199-01P
2	Adjusting Screw	R199-02
3	Housing Cap	R199-04
4	Spring Button	R130-06
5	Adjusting Spring	R199-07
6	Slip Ring	R130-08
7	✦ Diaphragm Assembly	R130-82A
7A	Diaphragm Nut	R240-10
7B	Diaphragm Plate	R130-14
7C	Seal Washer	R130-15
7D	Diaphragm	R130-16A
7E	Centralizer	R130-18
8	Nozzle	R130-30
9	✦ Seat Assembly	R160-83A
10	Valve Spring	R110-35
11	Gland	R110-36
12	✦ Friction Washer	R110-37
13	✦ Gasket	R110-38
14	Body	R199-50
15	✦ H.P. Gauge	G20P-4000
16	✦ Filter	R110-56
17	Inlet Stem	CO-3P
18	✦ Inlet Nut	806-1P
19	✦ Washer	CO-6N
20	Flowmeter Inlet	R195-51P
21	Outlet Connection	R195-52P
22	Flowmeter Body	R195-59DP
23	✦ O-Ring Large	R195-60
24	✦ O-Ring Small	R195-61
25	✦ Tube	R195-62
26	✦ Ball Float	T130-30
27	✦ Washer	R195-73
28	✦ O-Ring	Y4903
29	✦ Hood	R195-66
30	FM Body Bushing	R195-67P
31	✦ Needle Valve Assembly	R195-93AP
32	✦ O-Ring	R120-13
33	✦ O-Ring Holder	R120-12
34	Spring	R190N-35
35	Adjusting Nut	R191-10P
36	Relief Valve	R140-87P

---

Ref. No.	Part Description	Part No.
36A	Valve Body	R140-70P
36B	Seat	R140-71
36C	Seat Retainer	R140-72
36D	Upper Seat	R140-73
36E	Disc	R140-74
36F	Spring	R140-75
36G	Cap	R140-76P

---

✦ Items most commonly required for regulator repair and recommended for stock.  
Repair kits include these items.

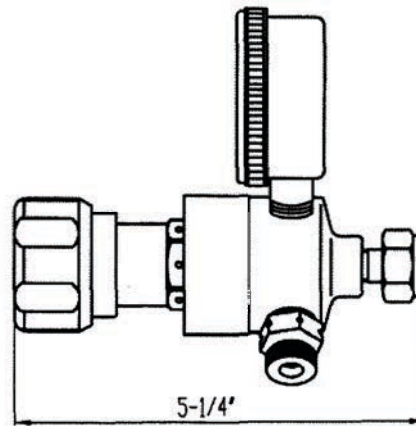
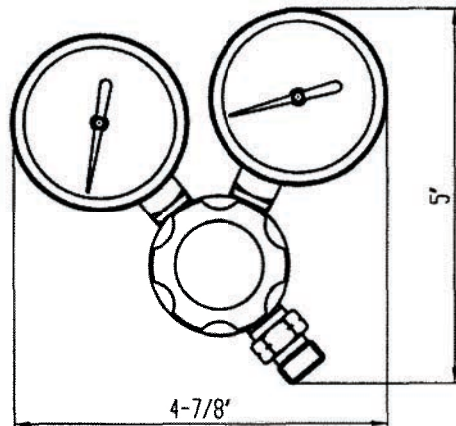

### MODEL INFORMATION

GAS SERVICE	MODEL NUMBER	MAX. DELIVERY PRESSURE (PSI)	INLET CONNECTION	OUTLET CONNECTION
OXYGEN	210X-80	4-80	CGA540 Rear	9/16"-18RH(M)
	210X-80-A	4-80	CGA540 Rear	3/8"-24RH(M)
ACETYLENE	210Y-15	2-15	CGA200"MC"Rear	9/16"-18LH(M)
	210Y-15-A	2-15	CGA200"MC"Rear	3/8"-24LH(M)
	210Y1-15-B	2-15	CGA520"B"Rear	9/16"-18LH(M)
	210Y1-15-M	2-15	CGA200"MC"Rear	3/8"-24LH(M)

CHART 1

Description	210Y-15 210Y-15-A	210X-80 210X-80-A	210Y1-15-B	210Y1-15-M
Adjusting Spring	R110-07	R120-07	R110-07	R110-07
H.P. Gauge	G20-400	G20-4000	G20-400	G20-400
L.P. Gauge	G20-030R	G20-100	N/A	N/A
Body	R210Y2-50	R210X2-50	R210Y1-50B	R210Y1P-50

CHART 2

#### Diaphragm Assembly&Filter

Description	210Y-15 210Y-15-A 210Y1-15-B 210Y1-15-M	210X-80 210X-80-A
Diaphragm Assembly	R110-82A	R120-82
Valve Spring	N/A	R120-11
Diaphragm Plate	R110-14	R110-14
O-Ring	N/A	R120-13
Diaphragm	R120-16D	R120-16D
Central Screw	R110-18	R120-18
Nut	N/A	R120-10
O-Ring Holder	N/A	R120-12
Filter	R210-56	R110-56
Filter Holder	R210Y1-59	N/A

CHART 3

Gas Service	Model No.	CGA INLET	Inlet Stem	Inlet Nut	Seat Assembly	Outlet Connection
Oxygen	210X-80	540Rear	R210X2-58	R120-57	R120-83D	R120-53
	210X-80-A	540Rear	R210X2-58	R120-57	R120-83D	R210X-53
Acetylene	210Y-15	200"MC"Rear	R210Y1-58	R321-2	R110-83B	R110-53
	210Y1-15-A	200"MC"Rea	R210Y1-58	R321-2	R110-83B	R210Y-53
	210Y1-15-B	520"B"Rear	R210Y1-55B	319-2	R110-83B	R110-53
	210Y1-15-M	200"MC"Rea	R210Y1-58	R321-2	R110-83B	R210Y-53

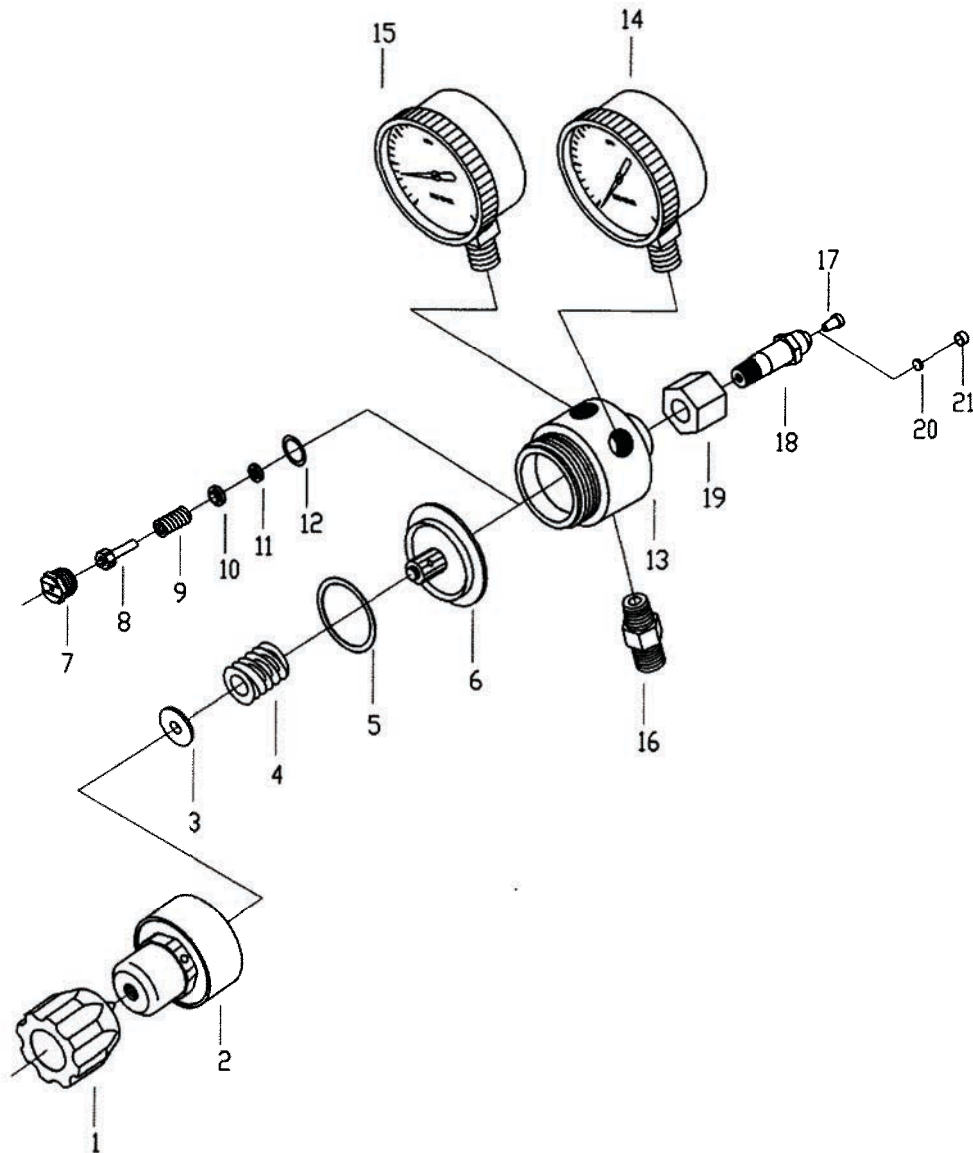



---

Ref. No.	Part Description	Part No.
1	Adjusting Knob	R190-01
2	Housing Cap	R190-04
3	Spring Button	R110-06
4	Adjusting Spring	See Chart 1
5	Slip Ring	R110-08
6	✦ Diaphragm Assembly	See Chart 2
7	Nozzle	R110-30
8	✦ Seat Assembly	See Chart 3
9	Valve Spring	R110-35
10	Gland	R110-36
11	✦ Friction Washer	R110-37
12	✦ Gasket	R110-38
13	Body	See Chart 1
14	✦ H.P. Gauge	See Chart 1
15	✦ L.P. Gauge	See Chart 1
16	✦ Outlet Connection	See Chart 3
17	✦ Filter	See Chart 2
18	Inlet Stem	See Chart 3
19	✦ Inlet Nut	See Chart 3
20	✦ Filter	See Chart 2
21	✦ Filter Holder	See Chart 2

---

✦ Items most commonly required for regulator repair and recommended for stock.  
Repair kits include these items.

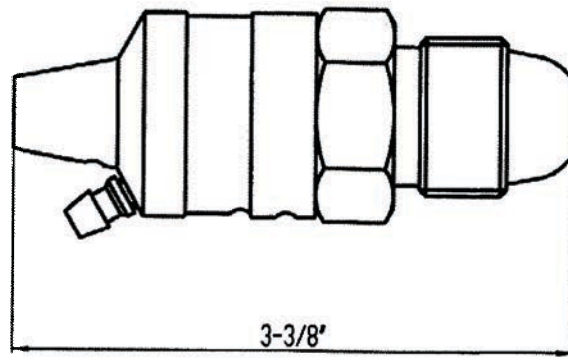

### MODEL INFORMATION

GAS SERVICE	MODEL NUMBER	MAX. DELIVERY PRESSURE (PSI)	INLET CONNECTION	OUTLET CONNECTION
ARGON Ar/CO2	220-50	50	CGA580	3/16" Barb

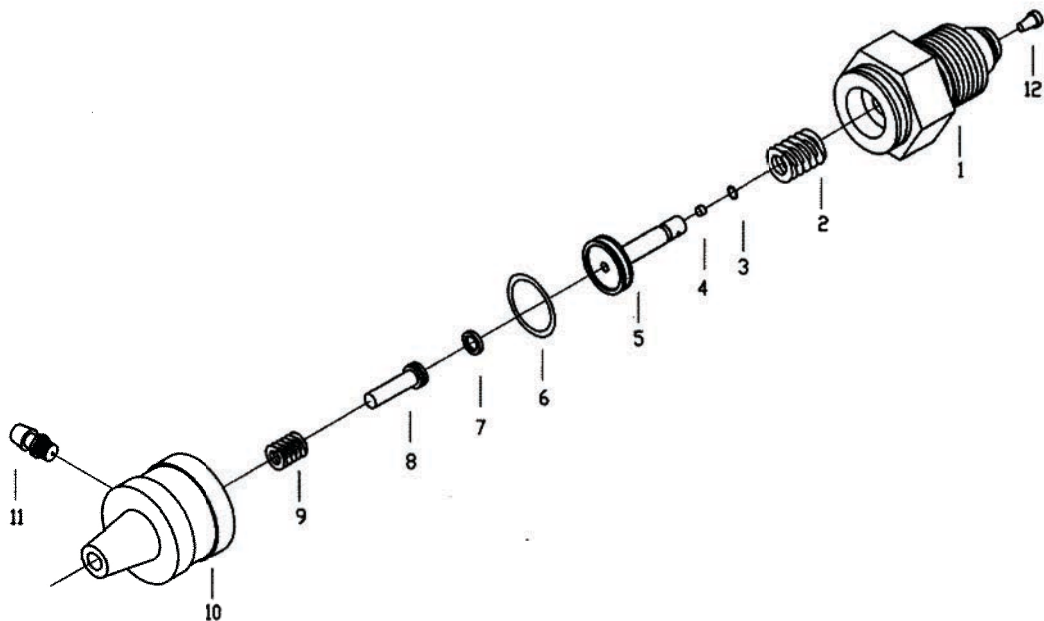

---

Ref. No.	Part Description	Part No.
1	Body	R210-50
2	Spring	R210-52
3	✦ O-Ring	R230-54
4	✦ Seat	R230-56
5	Seat Holder	R210-58
6	✦ O-Ring	R230-60
7	✦ Seal	R210-62
8	Indicator Piston	R210-64
9	Spring	R210-66
10	Cap	R210-68
11	✦ Outlet Connection	R210-70
12	✦ Filter	R110-56

---

✦ Items most commonly required for regulator repair and recommended for stock.

Repair kits include these items.

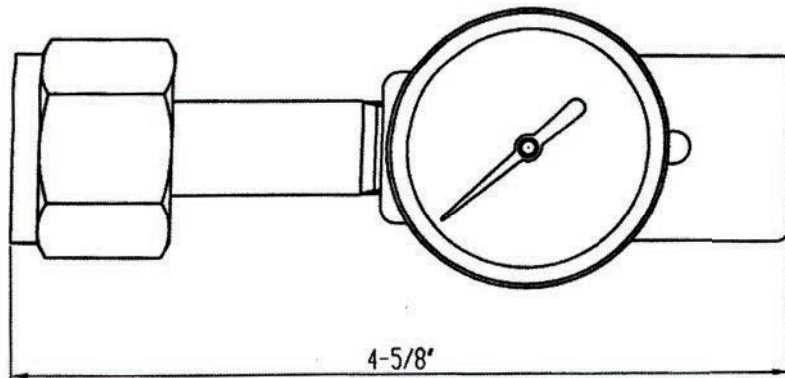

**MODEL INFORMATION**

GAS SERVICE	MODEL NUMBER	MAX. DELIVERY PRESSURE (PSI)	INLET CONNECTION	OUTLET CONNECTION
CARBON DIOXIDE	227C 227CG	50	CGA320	1/4"NPT(F)
ARGON Ar/CO2	227N 227NG	50	CGA580	1/4"NPT(F)

**CHART 1**

GAS SERVICE	MODEL NUMBER	CGA INLET	INLET STEM	INLET NUT	GAUGE
CARBON DIOXIDE	227C 227CG	320 320	CO-3 CO-3	806-1 806-1	N/A GR15-3MEF
ARGON Ar/CO2	227N 227NG	580 580	RNP15-23SF RNP15-23SF	R190-54 R190-54	N/A GR15-3MEF

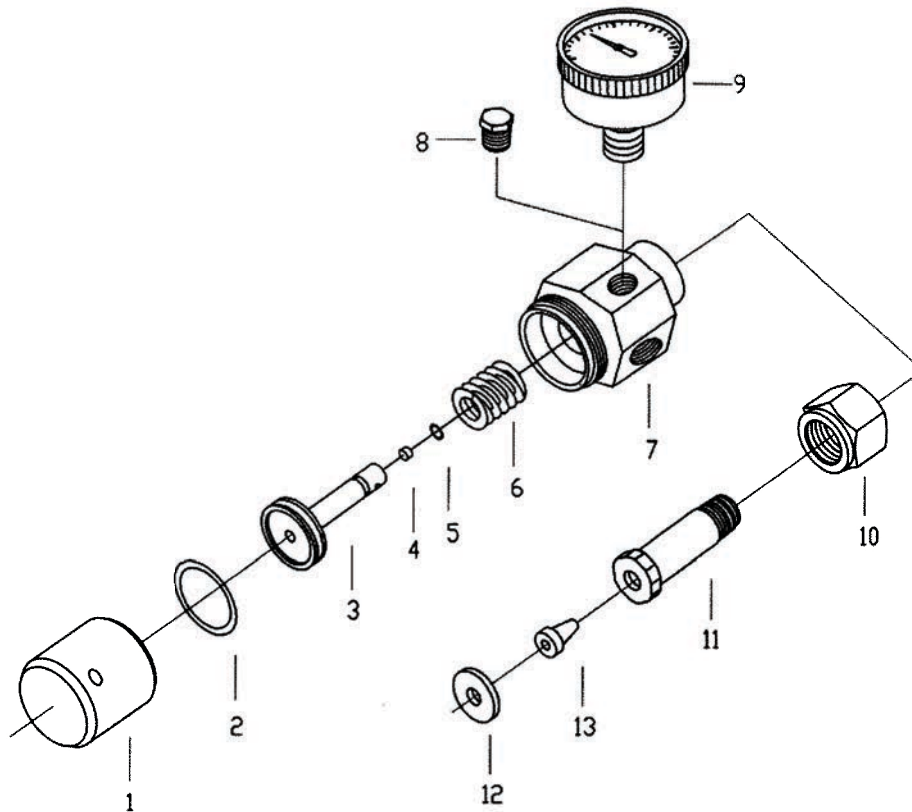

Ref. No.	Part Description	Part No.
1	Cap	R227-62
2	O-Ring	R230-61
3	Seat Holder	R230-58
4	✦ Seat	R230-56
5	✦ O-Ring	R230-54
6	Spring	R230-75A
7	Body	R227-50
8	Plug	RP-2HP
9	✦ Gauge	See Chart 1
10	✦ Inlet Nut	See Chart 1
11	Inlet Stem	See Chart 1
12	✦ Washer	CO-6N
13	✦ Filter	R110-56

**Notice:** Ref. No.12 CO-6N for CGA320 only.

✦ Items most commonly required for regulator repair and recommended for stock.

**Repair kits include these items.**

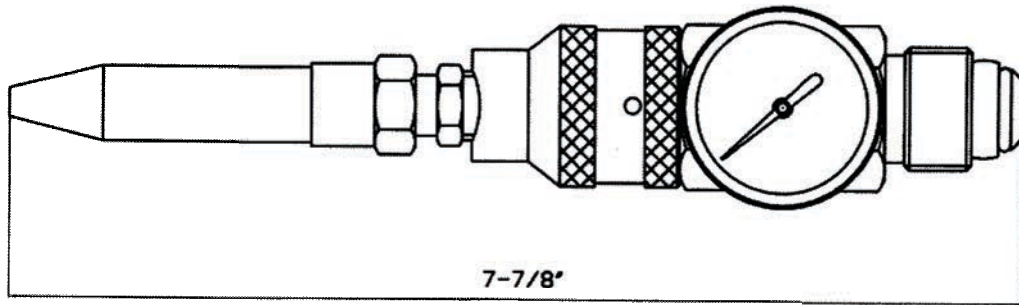

### MODEL INFORMATION

GAS SERVICE	MODEL NUMBER	MAX. DELIVERY PRESSURE (PSI)	INLET CONNECTION	OUTLET CONNECTION
ARGON Ar/CO2	229-50-B	50	CGA580	3/16 " Barb
	229-50-P			5/32 Push-In-Tube
HELIUM	229 229G	50	CGA580	/

CHART 1

Description	229-50-B	229-50-P	229	229G
H.P. Gauge	N/A	N/A	N/A	GR15-3000RF
Body	R229-50	R229-50	R229-50	R229-50A
Outlet Connection	ROB316	ROB532	RB232	RB232

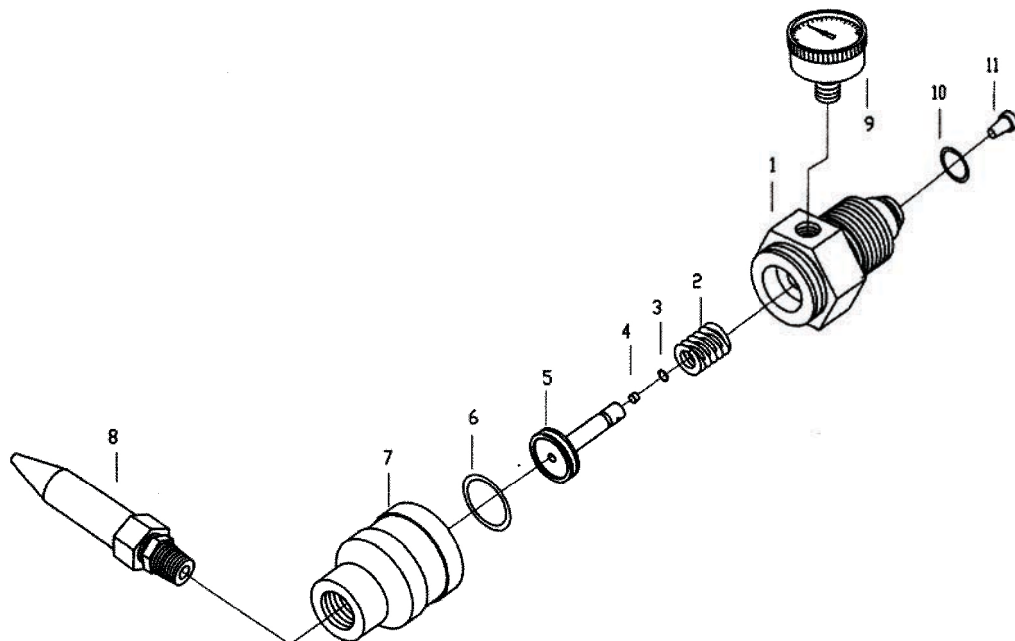

---

Ref. No.	Part Description	Part No.
1	Body	See Chart 1
2	Spring	R230-52
3	✦ O-Ring	R230-54
4	✦ Seat	R230-56
5	Seat Holder	R230-58
6	✦ O-Ring	R230-61
7	Cap	R229-62
8	✦ Outlet	See Chart 1
9	✦ Gauge	See Chart 1
10	✦ O-Ring	R570-66
11	✦ Filter	R110-56

---

✦ Items most commonly required for regulator repair and recommended for stock.  
Repair kits include these items.

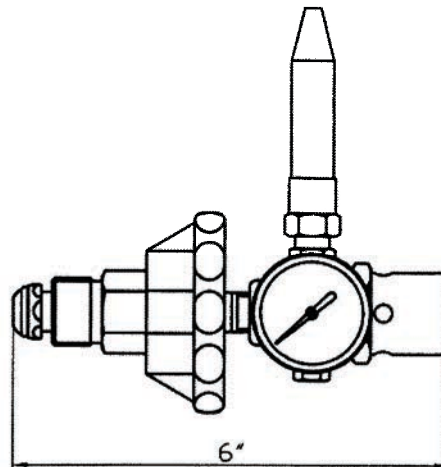

### MODEL INFORMATION

GAS SERVICE	MODEL NUMBER	INLET CONNECTION
HELIUM	230	CGA580
	230A	CGA580
	230G	CGA580
	230GA	CGA580
	230HB	CGA580 Hand Tight
	230HBA	CGA580 Hand Tight
	230HBG	CGA580 Hand Tight
	230HBGA	CGA580 Hand Tight
	230H	CGA580 Hand Tight
	230HA	CGA580 Hand Tight
	230HG	CGA580 Hand Tight
	230HGA	CGA580 Hand Tight

CHART 1

Gas Service	Model No.	CGA INLET	Inlet Stem	Inlet Nut	Gauge	O-Ring
HELIUM	230	580	R210Y2-55	R190-54	N/A	N/A
	230A	580	R210Y2-55	R190-54	N/A	N/A
	230G	580	R210Y2-55	R190-54	GR15-3MEF	N/A
	230GA	580	R210Y2-55	R190-54	GR15-3MEF	N/A
	230HB	580 Hand Tight	R230-55	R230-53	N/A	R570-66
	230HBA	580 Hand Tight	R230-55	R230-53	N/A	R570-66
	230HBG	580 Hand Tight	R230-55	R230-53	GR15-3MEF	R570-66
	230HBGA	580 Hand Tight	R230-55	R230-53	GR15-3MEF	R570-66
	230H	580 Hand Tight	R615-3	R692P	N/A	R570-66
	230HA	580 Hand Tight	R615-3	R692P	N/A	R570-66
	230HG	580 Hand Tight	R615-3	R692P	GR15-3MEF	R570-66
	230HGA	580 Hand Tight	R615-3	R692P	GR15-3MEF	R570-66



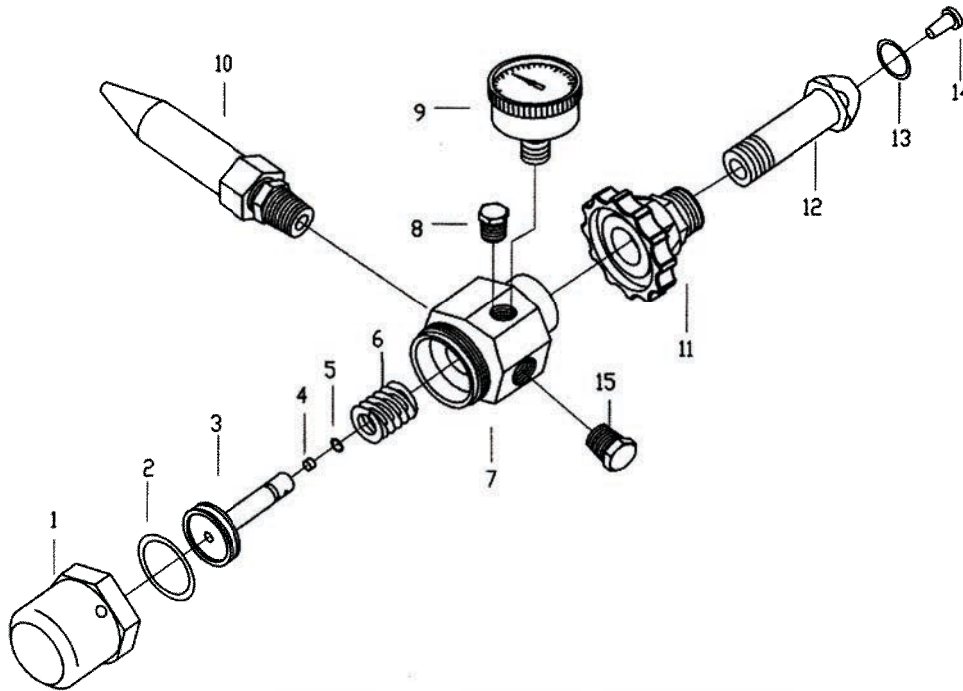

Ref. No.	Part Description	Part No.			
		230	230A	230G	230GA
		230HB	230HBA	230HBG	230HBGA
		230HB	230HA	230HG	230HGA
1	Cap	R230-62	R230-62	R230-62	R230-62
2	✦ O-Ring	R230-60	R230-60	R230-60	R230-61
3	Seat Holder	R230-58	R230-58	R230-58	R230-58
4	✦ Seat	R230-56	R230-56	R230-56	R230-56
5	✦ O-Ring	R230-54	R230-54	R230-54	R230-54
6	Spring	R230-52	R230-52	R230-52	R230-52
7	Body	R231-50	R231-50	R231-50	R231-50
8	Plug	RP-4HP	RP-2HP	N/A	N/A
9	✦ Gauge	N/A	N/A	See Chart 1	See Chart 1
10	✦ Tilt Valve Assembly	RB232	RB232	RB232	RB232
11	✦ Inlet Nut	See Chart 1	See Chart 1	See Chart 1	See Chart 1
12	Inlet Stem	See Chart 1	See Chart 1	See Chart 1	See Chart 1
13	✦ O-Ring	See Chart 1	See Chart 1	See Chart 1	See Chart 1
14	✦ Filter	R110-56	R110-56	R110-56	R110-56
15	Plug	RP-4HP	RP-4HP	RP-4HP	RP-4HP
Accessories	✦ Tie Hook	N/A	RB236	N/A	RB236
	✦ String Cutter	N/A	RB237	N/A	RB237

✦ Items most commonly required for regulator repair and recommended for stock.

Repair kits include these items.

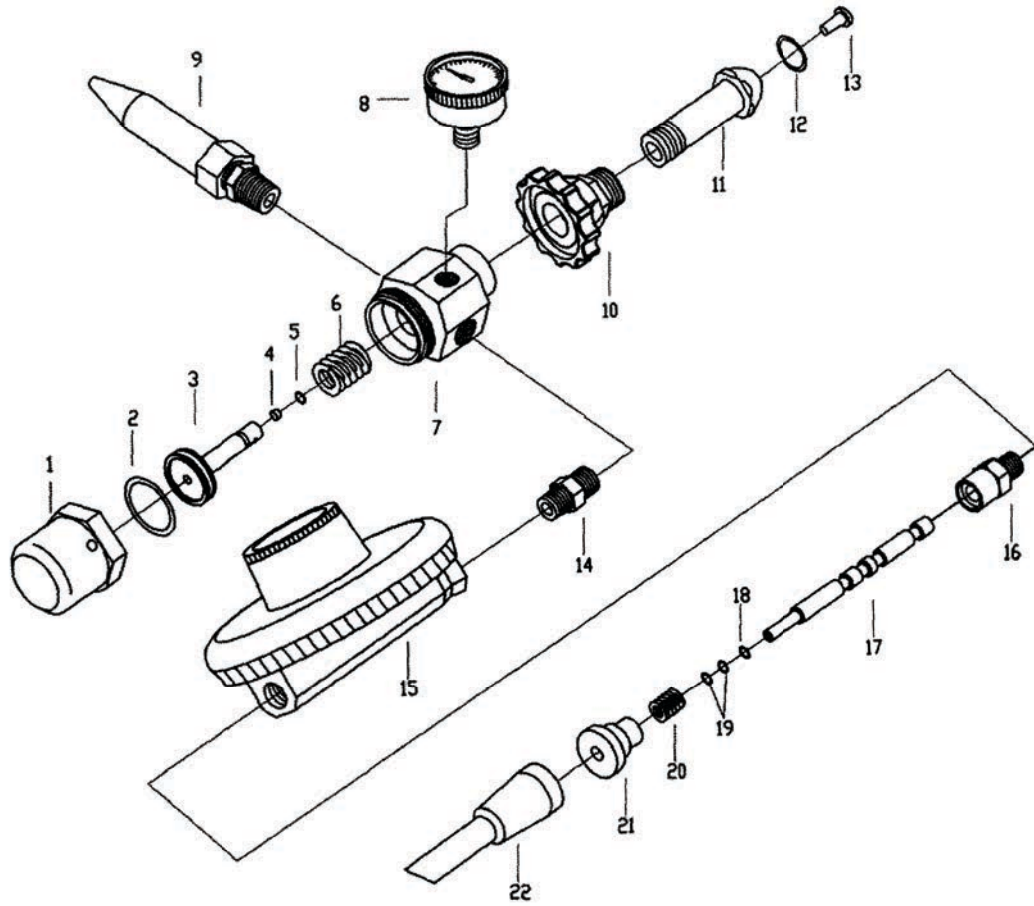

---

Ref. No.	Part Description	Part No.
1	Cap	R230-62
2	✦ O-Ring	R230-61
3	Seat Holder	R230-58
4	✦ Seat	R230-56
5	✦ O-Ring	R230-54
6	Spring	R230-52
7	Body	R231-50
8	✦ Gauge	GR15-3MEF
9	✦ Tilt Valve Assembly	RB232
10	✦ Inlet Nut	R692P
11	Inlet Stem	R615-3
12	✦ O-Ring	R570-66
13	✦ Filter	R110-56
14	Helium Regulator Inlet	R195-51E
15	Helium Regulator	250LPG
16	Helium Regulator Outlet	R250-10
17	Piston	R250-58
18	✦ O-Ring	T360-44
19	✦ O-Ring	T346-19
20	Spring	R250-11
21	O-Ring Holder	R250-12
22	Balloon Tip	R250-13

---

✦ Items most commonly required for regulator repair and recommended for stock.  
Repair kits include these items.

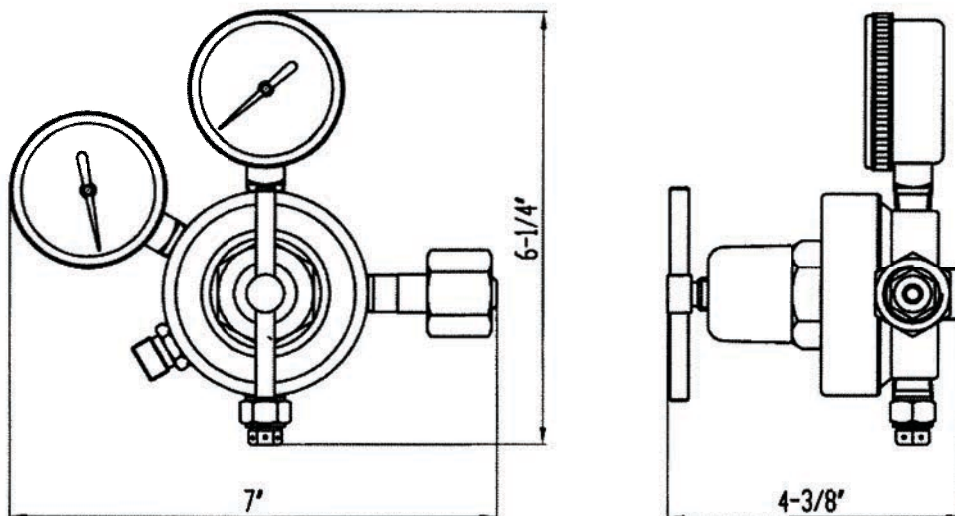

### MODEL INFORMATION

#### 452 SERIES

GAS SERVICE	MODEL NUMBER	MAX. DELIVERY PRESSURE (PSI)	INLET CONNECTION	OUTLET CONNECTION
L.P.G. GAS	452F-40	2-40	CGA510	9/16"-18LH(M)
	452F-125	5-125	CGA510	9/16"-18LH(M)
OXYGEN	452X-80	4-80	CGA540	9/16"-18RH(M)
	452X-175	5-175	CGA540	9/16"-18RH(M)
ACETYLENE	452Y-15	2-15	CGA510	9/16"-18LH(M)
	452Y-15-3	2-15	CGA300	9/16"-18LH(M)
	452Y-15-5	2-15	CGA520	9/16"-18LH(M)
INERT GAS (Ar, HE, N <sub>2</sub> )	452IN-80	4-80	CGA580	9/16"-18RH(M)
	452IN-450	30-450	CGA580	9/16"-18RH(M)
CARBON DIOXIDE	452C-175	5-175	CGA320	9/16"-18RH(M)
	452C-175-F	5-175	CGA320	1/4" SAME Flare
	452C-300	20-300	CGA320	9/16"-18RH(M)
	452C-300-F	20-300	CGA320	1/4" SAME Flare
NITROGEN	452N-175	5-175	CGA580	9/16"-18RH(M)
	452N-175-F	5-175	CGA580	1/4" SAME Flare
	452N-300	20-300	CGA580	9/16"-18RH(M)
	452N-300-F	20-300	CGA580	1/4" SAME Flare
	452N-450	30-450	CGA580	9/16"-18RH(M)
	452N-450-F	30-450	CGA580	1/4" SAME Flare

#### 453 SERIES

GAS SERVICE	MODEL NUMBER	MAX. DELIVERY PRESSURE (PSI)	INLET CONNECTION	OUTLET CONNECTION
OXYGEN	453X-175	5-175	CGA540	9/16"-18RH(M)
ACETYLENE	453Y-15	2-15	CGA510	9/16"-18LH(M)
	453Y-15-3	2-15	CGA300	9/16"-18LH(M)

CHART 1

Description	452F-40	452F-125	452Y-15 452Y-15-3 452Y-15-5 453Y-15 453Y-15-3	452X-80 452IN-80
Adjusting Spring	R240-07	R452X-07D	R130-07	R240-07
H.P. Gauge	G20-400	G20-400	G20-400	G20-4000
L.P. Gauge	G20-60	G20-200	G20-030R	G20-100
Body	R230-50	R230-50	R230-50	R240-50
Housing Cap	R230-04	R230-04	R230-04	R230-04
Adjusting Knob	R130-01	R230-01	R230-01	R230-01
Slip Ring	R230-08	R230-08	R230-08	R230-08
Spring Button	R130-06	R130-06	R130-06	R130-06

Description	452X-175 452C-175 452C-175-F 452N-175 452N-175-F	452C-300 452C-300-F 452N-300 452N-300-F	452IN-450 452N-450 452N-450-F
Adjusting Spring	R452N-07	R452F-07	R452F-07B
H.P. Gauge	G20-4000	G20-4000	G20-4000
L.P. Gauge	G20-300	G20-400	G20-600
Body	R240-50	R240-50B	R240-50B
Housing Cap	R230-04	R240-81B	R240-04B
Adjusting Knob	R230-01	R240-01B	R240-80B
Slip Ring	R230-08	R240-08	R240-08
Spring Button	R230-06	R240-06	R240-06

Description	453Y-15 453Y-15-3	453X-175
Adjusting Spring	R130-07	R452N-07
H.P. Gauge	G25B-400	G25B-4000
L.P. Gauge	G25B-030RL	G25B-300
Body	R230-50	R240-50
Housing Cap	R230-04	R230-04
Adjusting Knob	R230-01	R230-01
Slip Ring	R230-08	R230-08
Spring Button	R130-06	R230-06

CHART 2

Relief Valve

Description	452X-80 452IN-80	452X-175 452C-175 452C-175-F 452N-175 452N-175-F 452N-175	452C-300 452C-300-F 452N-300 452N-300-F	452IN-450 452N-450 452N-450-F
Relief Valve	R140-87	R160-87	R153N-87	R153F-87
Valve Body	R140-70	R140-70	R153F-70	R153F-70
Upper Seat	R140-73	R140-73	R153F-73	R153F-73
Spring	R140-75	R160-75	R153F-75	R153F-75
Cap	R140-76	R140-76	R153F-76	R153F-76

CHART 3

Description	452F-40 452F-125 452Y-15 452Y-15-3 452Y-15-5 453Y-15 453Y-15-3 452X-80 452X-175 453X-175 452IN-80 452C-175 452C-175-F 452N-175 452N-175-F	452IN-450 452C-300 452C-300-F 452N-300 452N-300-F 452N-450 452N-450-F
Diaphragm Assembly	R230-82A	R452N-82
Diaphragm Plate	R230-14	R240-14
Seat Washer	R130-15	R160-17
Diaphragm	R230-16A	R240-16C
Centralizer	R130-18	R240-18
Diaphragm Nut	R130-10	R240-10

CHART 4

Gas Service	Model No.	CGA INLET	Inlet Stem	Inlet Nut	Nozzle	Seat Assembly	Outlet Connection
LPG.	452F-40	510 510	R110-55	R110-54	R130-30	R130-83	R110-53
	452F-125		R110-55	R110-54	R130-30	R130-83	R110-53
Oxygen	452X-80	540 540 540	R120-58	R120-57	R110-30	R120-83	R120-53
	452X-175		R120-58	R120-57	R110-30	R120-83	R120-53
	453X-175		R120-58	R120-57	R110-30	R120-83	R120-53
Acetylene	452Y-15	510 300 520 510 300	R110-55	R110-54	R130-30	R130-83	R110-53
	452Y-15-3		R110-58	806-1 319-2	R130-30	R130-83	R110-53
	452Y-15-5		R210Y1-55B	RNT15-2	R130-30	R130-83	R110-53
	453Y-15		R110-55	RNT16-2	R130-30	R130-83	R110-53
	453Y-15-3		RNP16-8SF		R130-30	R130-83	R110-53
Inert Gas	452IN-80	580 580	R110-55	R190-54	R110-30	R120-83	R195-52A
	452IN-450		R110-55	R190-54	R110-30	R120-83	R195-52A
Carbon Dioxide	452C-175	320 320 320 320	CO-3		R110-30	R120-83	R195-52
	452C-175-F		CO-3	806-1 806-1	R110-30	R120-83	ROB48F
	452C-300		RNPCO3-SF	806-1 806-1	R110-30	R120-83	R195-52A
	452C-300-F		RNPCO3-SF		R110-30	R120-83	ROB48F
Nitrogen	452N-175	580 580 580 580 580 580	R110-55	R190-54	R110-30	R120-83	R195-52AR
	452N-175-F		RNP15-3SF	R190-54	R110-30	R120-83	OB48F
	452N-300		R110-55	R190-54	R110-30	R120-83	R195-52AR
	452N-300-F		RNP15-3SF	R190-54	R110-30	R120-83	OB48F
	452N-450		R110-55	R190-54	R110-30	R120-83	R195-52A
	452N-450-F		R110-55	R190-54	R110-30	R120-83	ROB48F

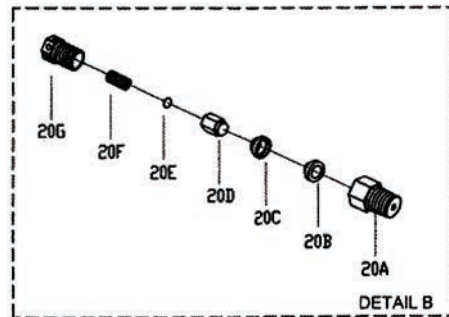
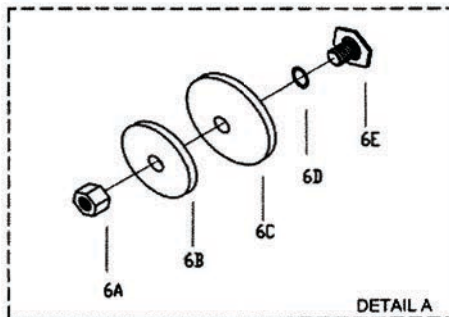
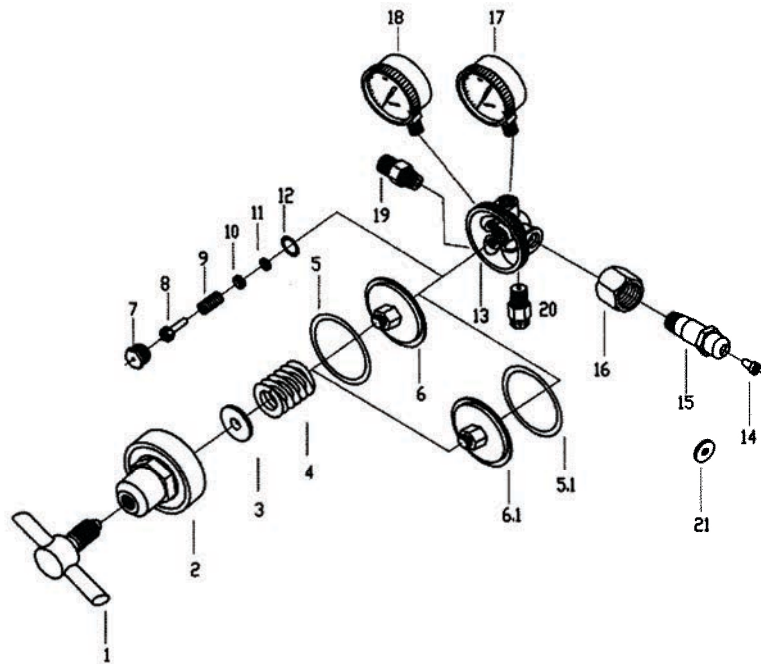
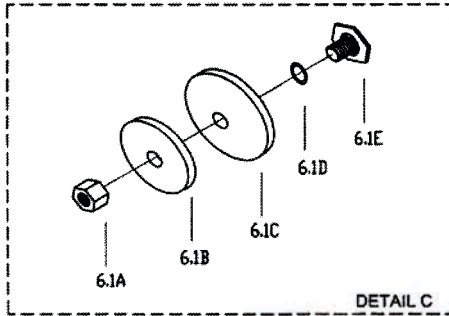

Ref. No.	Part Description	Part No.
1	Adjusting Screw	See Chart 1
2	Housing Cap	See Chart 1
3	Spring Button	See Chart 1
4	Adjusting Spring	See Chart 1
5	Slip Ring	See Chart 1
5.1	Slip Ring	See Chart 1
6	✦ Diaphragm Assembly	See Chart 3
6A	Diaphragm Nut	See Chart 3
6B	Diaphragm Plate	See Chart 3
6C	Seal Washer	See Chart 3
6D	Diaphragm	See Chart 3
6E	Centralizer	See Chart 3
6.1	✦ Diaphragm Assembly	See Chart 3
6.1A	Diaphragm Nut	See Chart 3
6.1B	Diaphragm Plate	See Chart 3
6.1C	Seal Washer	See Chart 3
6.1D	Diaphragm	See Chart 3
6.1E	Centralizer	See Chart 3
7	Nozzle	See Chart 4
8	✦ Seat Assembly	See Chart 4
9	Valve Spring	R110-35
10	Gland	R110-36
11	✦ Friction Washer	R110-37
12	✦ Gasket	R110-38
13	Body	See Chart 1
14	✦ Filter	R110-56
15	Inlet Stem	See Chart 4
16	✦ Inlet Nut	See Chart 4
17	✦ H.P. Gauge	See Chart 1
18	✦ L.P. Gauge	See Chart 1
19	✦ Outlet Connection	See Chart 4
20	Relief Valve	See Chart 2
20A	Valve Body	See Chart 2
20B	Seat	R140-74
20C	Seat Retainer	R140-72
20D	Upper Seat	See Chart 2
20E	Disc	R140-71
20F	Spring	See Chart 2
20G	Cap	See Chart 2
21	✦ Washer	CO-6N

Notice: Ref. No.21 CO-6N for CGA320 only.

✦ Items most commonly required for regulator repair and recommended for stock.  
Repair kits include these items.



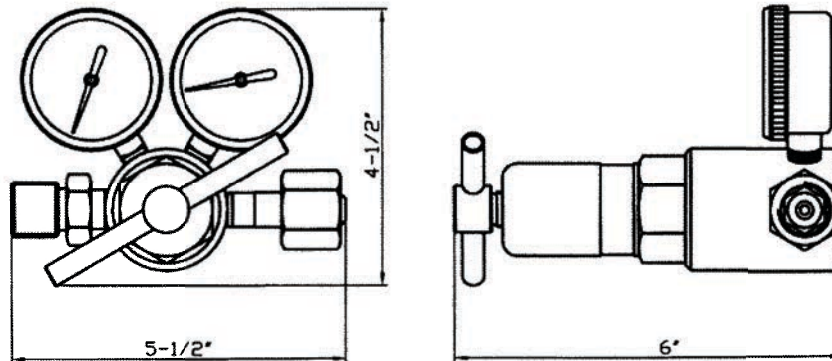

### MODEL INFORMATION

GAS SERVICE	MODEL NUMBER	MAX. DELIVERY PRESSURE (PSI)	INLET CONNECTION	OUTLET CONNECTION
OXYGEN	591X-750	50-750	CGA540	1/4"-SWAGEDLOCK
	591X-1500	100-500		
	591X-3000	200-3000		
INERT GAS (Ar,He,N2)	591IN-1500	100-1500	CGA580	1/4"-SWAGEDLOCK
	591IN-3000	200-3000		
	591IN-1500-680	100-1500	CGA680	
	591IN-3000-680	200-3000	CGA680	
	591IN-4500-680	300-4500	CGA680	
AIR	591Q-1500	100-1500	CGA346	1/4"-SWAGEDLOCK
	591Q-3000	200-3000		
	591Q-1500-680	100-1500	CGA680	
	591Q-3000-680	200-3000	CGA680	
	591Q-4500-680	300-4500	CGA680	
HYDRPGEN	591H-750	50-750	CGA350	1/4"-SWAGEDLOCK
	591H-1500	100-1500		
	591H-3000	200-3000		

CHART 1

Description	591X-750 591H-750	591X-1500 591IN-1500 591Q-1500 591H-1500	591X-3000 591IN-3000 591Q-3000 591H-3000	591Q-1500-680 591IN-1500-680
Adjusting Spring	SR4-07A	SR4-07A	SR4-07C	SR4-07A
H.P. Gauge	G25B-4000	G25B-4000	G25B-4000	G25B-6000
L.P. Gauge	G25B-1000	G25B-3000	G25B-4000	G25B-3000
Description	591Q-3000-680 591IN-3000-680	591Q-4500-680 591IN-4500-680		
Adjusting Spring	SR4-07C	R591-07		
H.P. Gauge	G25B-6000	G25B-6000		
L.P. Gauge	G25B-4000	G25B-6000		

CHART 2

Gas Service	CGA INLET	Inlet Stem	Inlet Nut	Body	Nozzle	Gland	Seat Assembly	Outlet Connection
Oxygen	540	R120-58	R120-57	SR4-50	R110-30	R110-36	R120-83	R591-52
Inert Gas (Ar, He, N <sub>2</sub> )	580	R110-55	R190-54	SR4-50	R110-30	R110-36	R120-83	R591-52
	680	R550-58C	R550-57C	SR4-50A	SR4-30	SR4-36	SR4-83	R591-52
Air	346	R120-58N	R120-57B	SR4-50	R110-30	R110-36	R120-83	R591-52
	680	R550-58C	R550-57C	SR4-50A	SR4-30	SR4-36	SR4-83	R591-52
HYDROGEN	350	R152H-58	R152H-57	SR4-50	R110-30	R110-36	R120-83	R591-52

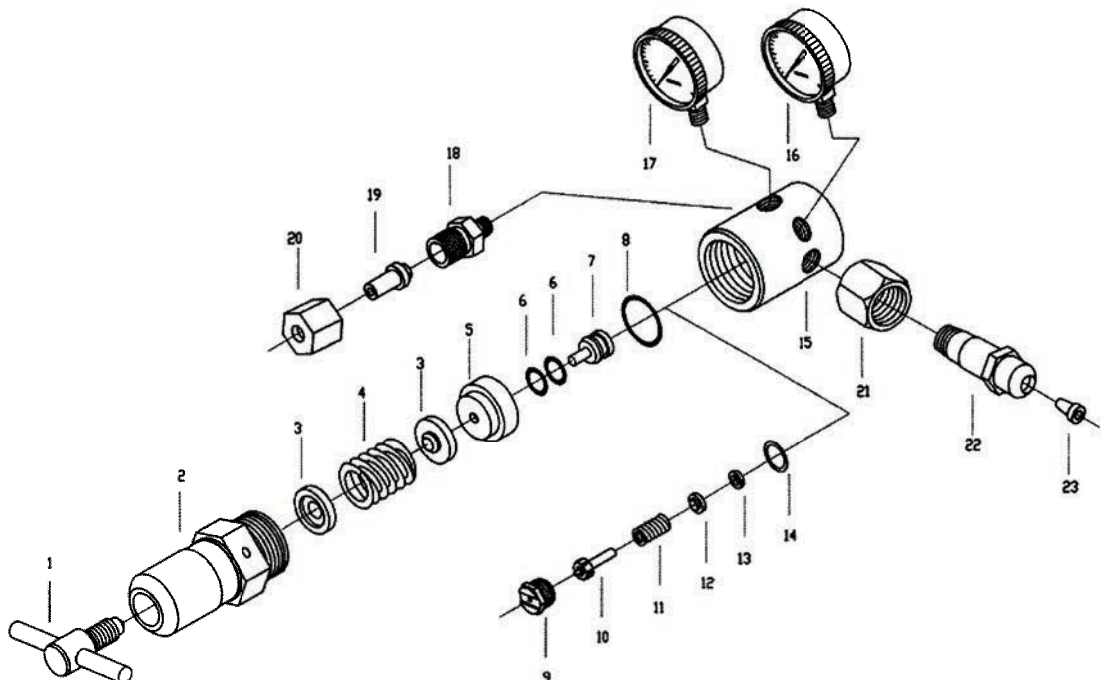

Ref. No.	Part Description	Part No.
1	Adjusting Screw	R591-01
2	Housing Cap	SR4-04
3	Spring Button	SR4-06
4	Adjusting Spring	See Chart 1
5	Centralizer	SR4-09
6	✦ O-Ring	T346-17
7	Piston	SR4-18
8	✦ O-Ring	SR4-12
9	Nozzle	See Chart 2
10	✦ Seat Assembly	See Chart 2
11	Valve Spring	R110-35
12	Gland	See Chart 2
13	✦ Friction Washer	R110-37
14	✦ Gasket	R110-38
15	Body	See Chart 2
16	✦ L.P. Gauge	See Chart 1
17	✦ H.P. Gauge	See Chart 1
18	✦ Outlet Connection	R591-52
19	Nipple	R591-59
20	Nut	R591-58
21	✦ Inlet Nut	See Chart 2
22	Inlet Stem	See Chart 2
23	✦ Filter	R110-56

✦ Items most commonly required for regulator repair and recommended for stock.

Repair kits include these items.

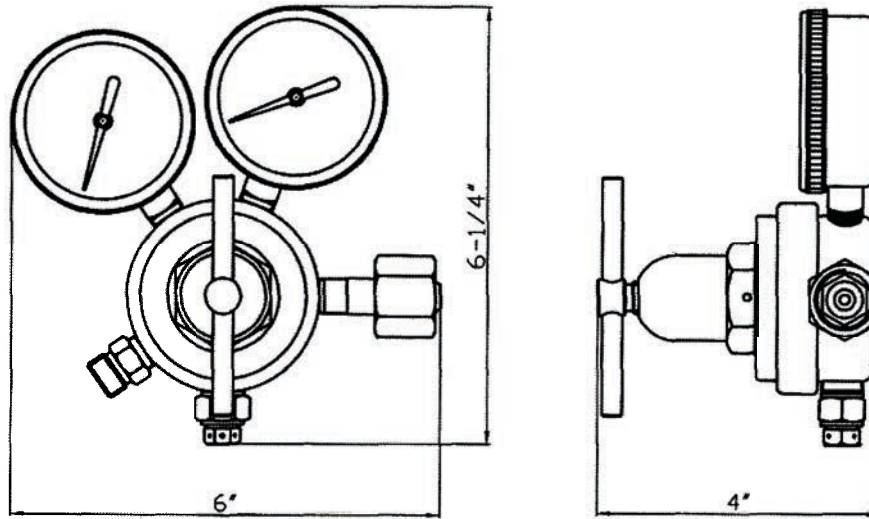

## MODEL INFORMATION

GAS SERVICE	MODEL NUMBER	MAX. DELIVERY PRESSURE (PSI)	INLET CONNECTION	OUTLET CONNECTION
L.P.G GAS	853F-80	4-80	CGA510	9/16"-18LH(M)
OXYGEN	853X-125	5-125	CGA540	9/16"-18RH(M)
ACETYLENE	853Y-15	2-15	CGA510	9/16"-18RH(M)
	853Y-15-3	2-15	CGA300	

CHART 1

Description	853Y-15	853F-80	853X-125
Adjusting Spring	R130-07	R452X-07D	R452N-07
H.P. Gauge	G25B-400	G25B-400	G25B-4000
L.P. Gauge	G25B-030RL	G25B-100	G25B-200
Body	R853-50	R853-50	R853-50C
Relief Valve	N/A	N/A	R160-87

CHART 2

Gas Service	CGA INLET	Inlet Stem	Inlet Nut	Seat Assembly	Outlet Connection
Oxygen	CGA540	R120-58	R120-57	R853-83	R120-53
LPG	CGA510	R110-55	R110-54	R853Y-83	R110-53
Acetylene	CGA510	R110-55	R110-54	R853Y-83	R110-53
	CGA300	R110-58	806-1		

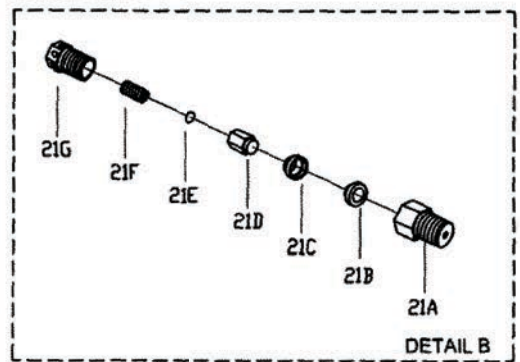
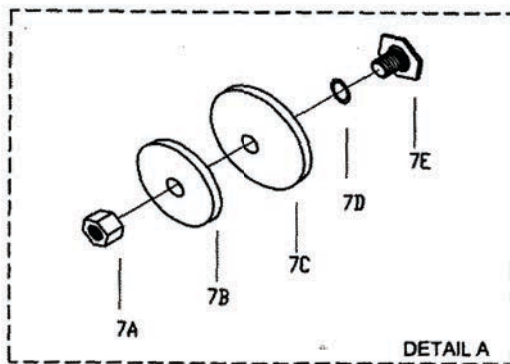
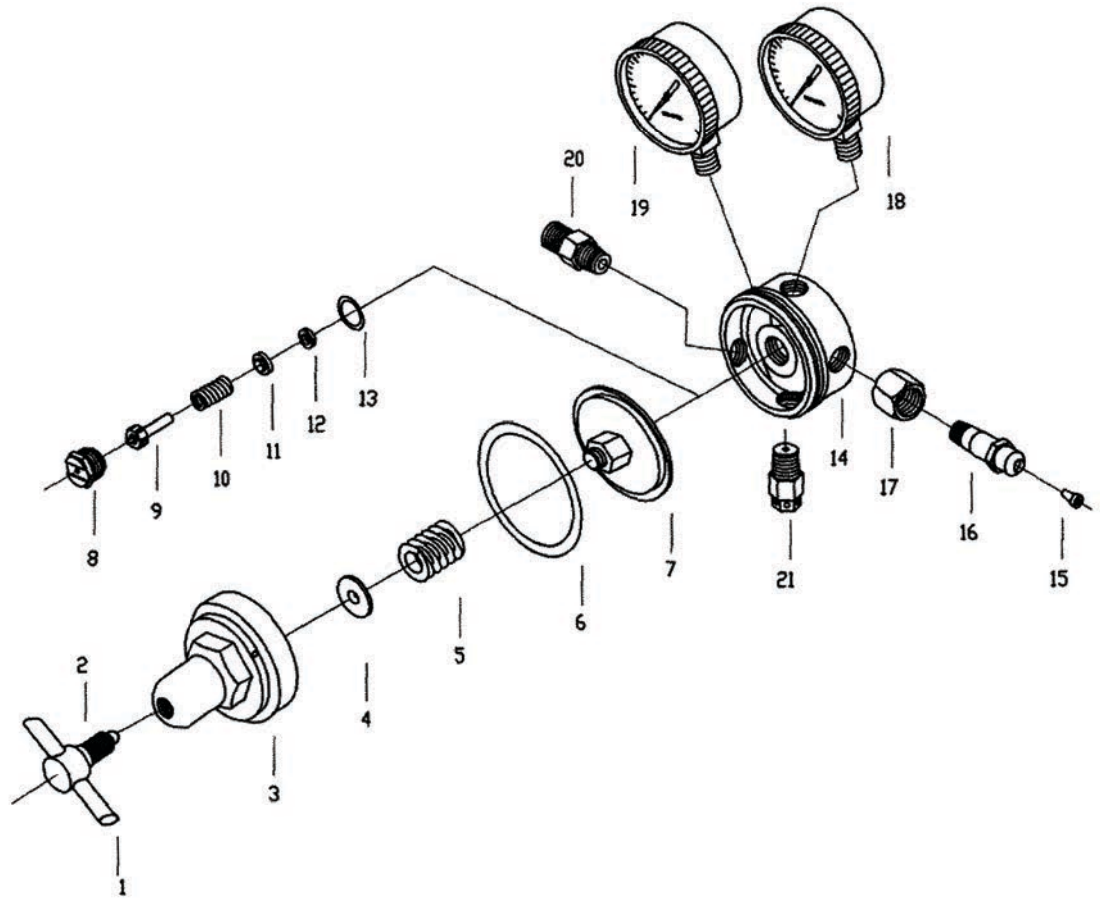

Ref. No.	Part Description	Part No.
1	Adjusting Screw	R853-01-01
2	Adjusting Stem	R853-01-02
3	Housing Cap	R853-04
4	Spring Button	R230-06
5	Adjusting Spring	See Chart 1
6	Slip Ring	R853-08
7	✦ Diaphragm Assembly	R853-82D
7A	Diaphragm Nut	R240-10
7B	Diaphragm Plate	R230-14
7C	Seal Washer	R130-15
7D	Diaphragm	R853-16
7E	Centralizer	R853-18
8	Nozzle	R150-30
9	✦ Seat Assembly	See Chart 2
10	Valve Spring	R150-35
11	Gland	R110-36
12	✦ Friction Washer	R110-37
13	✦ Gasket	R110-38
14	Body	See Chart 1
15	✦ Filter	R110-56
16	Inlet Stem	See Chart 2
17	✦ Inlet Nut	See Chart 2
18	✦ H.P. Gauge	See Chart 1
19	✦ L.P. Gauge	See Chart 1
20	✦ Outlet Connection	See Chart 2
21	Relief Valve	R160-87
21A	Valve Body	R140-70
21B	Seat	R140-71
21C	Seat Retainer	R140-72
21D	Upper Seat	R140-73
21E	Disc	R140-74
21F	Spring	R160-75
21G	Cap	R140-76

✦ Items most commonly required for regulator repair and recommended for stock.

Repair kits include these items.

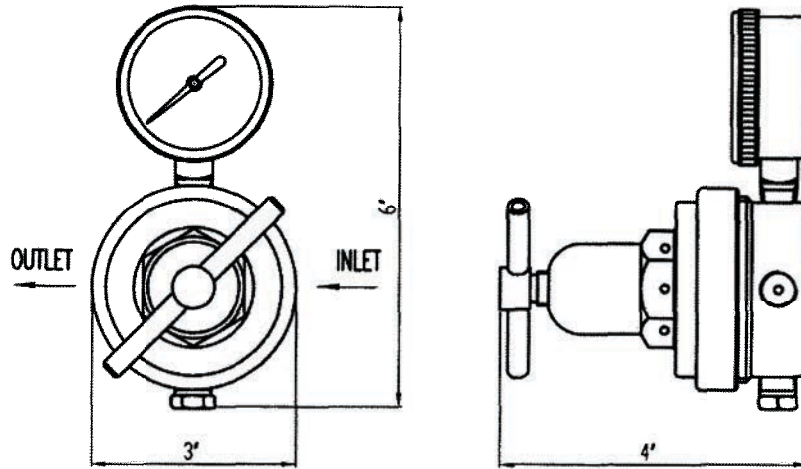

**MODEL INFORMATION**

GAS SERVICE	MODEL NUMBER	MAX. DELIVERY PRESSURE (PSI)	INLET CONNECTION	OUTLET CONNECTION
L.P.G. GAS	853LF-125	5-125	1/4"NPT(F)	1/4"NPT(F)
OXYGEN	853LX-125	5-125	1/4"NPT(F)	1/4"NPT(F)
ACETYLENE	853LY-15	2-15	1/4"NPT(F)	1/4"NPT(F)

**CHART 1**

Description	853LY-15	853LF-80	853lx-125
Adjusting Spring	R130-07	R452N-07	R452N-07
L.P. Gauge	G25B-030R	G25B-200	G25B-200
Seat Assembly	R853Y-83	R853Y-83	R853-83

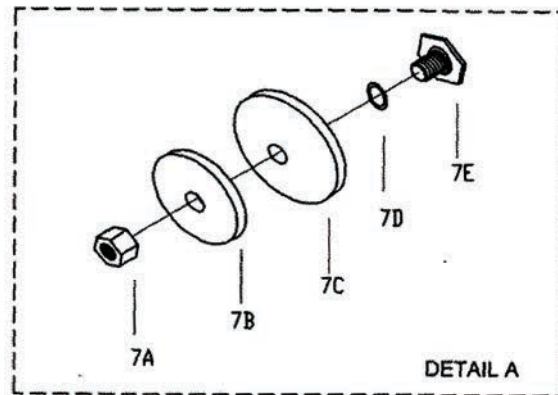
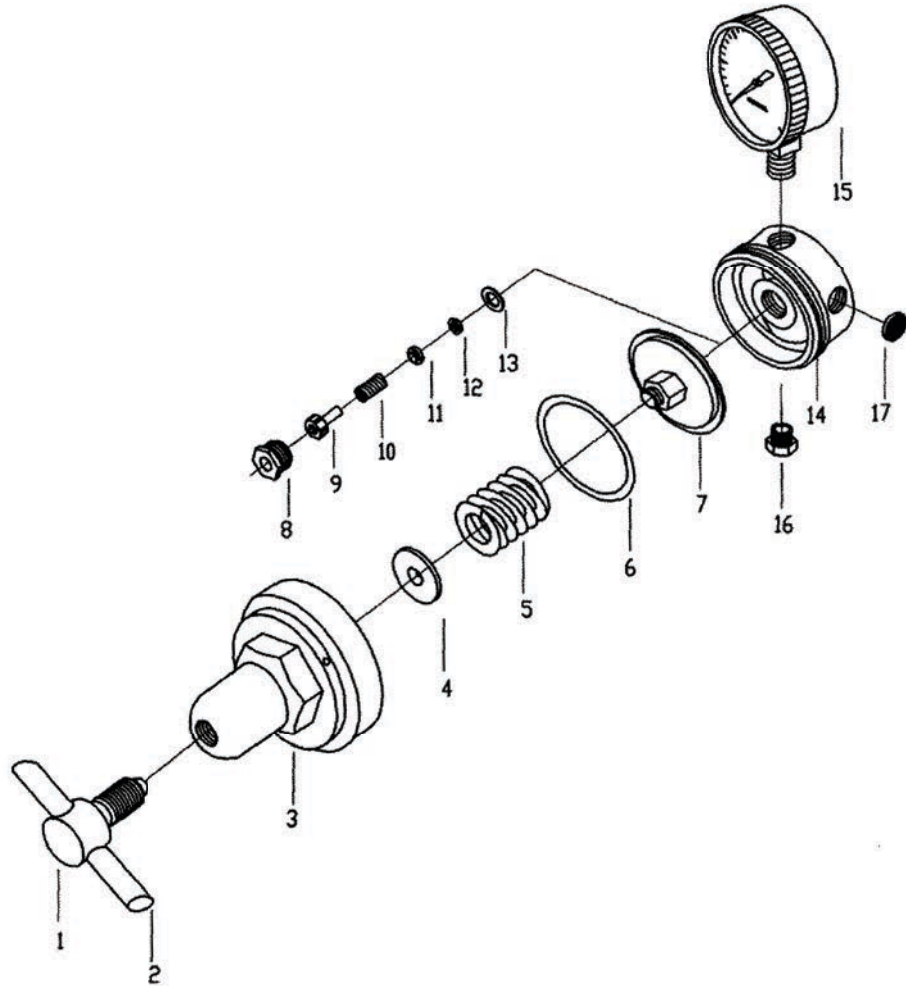



---

Ref. No.	Part Description	Part No.
1	Adjusting Screw	R853-01-01
2	Adjusting Stem	R853-01-02
3	Housing Cap	R853-04
4	Spring Button	R230-06
5	Adjusting Spring	See Chart 1
6	Slip Ring	R853-08
7	✦ Diaphragm Assembly	R853-82D
7A	Diaphragm Nut	R240-10
7B	Diaphragm Plate	R230-14
7C	Seal Washer	R130-15
7D	Diaphragm	R853-16
7E	Centralizer	R853-18
8	Nozzle	R150-30
9	✦ Seat Assembly	See Chart 1
10	Valve Spring	R150-35
11	Gland	R110-36
12	✦ Friction Washer	R110-37
13	✦ Gasket	R110-38
14	Body	R853-50B
15	✦ L.P. Gauge	See Chart 1
16	Plug	RP-4HP
17	✦ Filter	R130-56

---

✦ Items most commonly required for regulator repair and recommended for stock.  
Repair kits include these items.

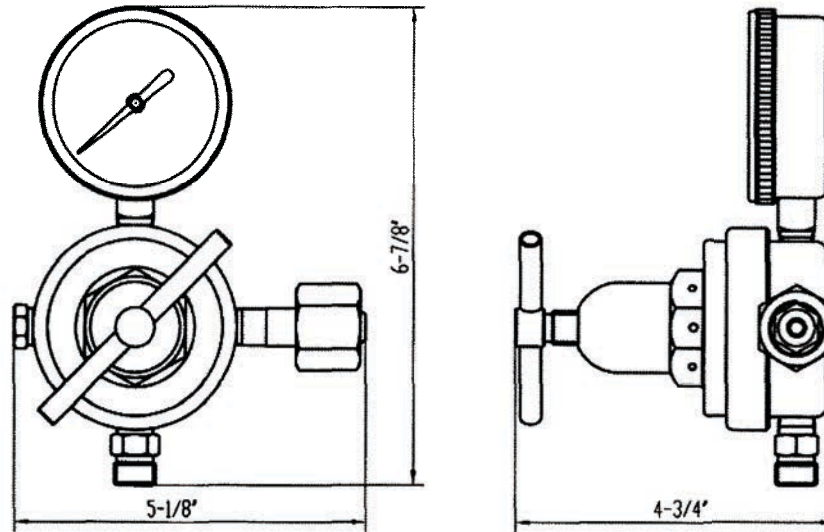

### MODEL INFORMATION

GAS SERVICE	MODEL NUMBER	MAX. DELIVERY PRESSURE (PSI)	INLET CONNECTION	OUTLET CONNECTION
L.P.G. GAS	853SF-80	4-80	7/8"-14LH(F)	9/16"-18LH(M)
OXYGEN	853SX-40	2-40	7/8"-14RH(F)	9/16"-18RH(M)
	853SX-80	4-80	7/8"-14RH(F)	9/16"-18RH(M)
	853SX-125	5-125	7/8"-14RH(F)	9/16"-18RH(M)
ACETYLENE	853SY-15	2-15	7/8"-14LH(F)	9/16"-18LH(M)

CHART 1

Description	853SY-15	853SF-80	853SX-40	853SX-80	853SX-125
Adjusting Spring	R130-07	R452X-07D	R152X-07	R452X-07D	R452N-07
L.P. Gauge	G25B-030RL	G25B-100	G25B-60	G25B-100	G25B-200

CHART 2

Gas Service	Inlet Stem	Inlet Nut	Seat Assembly	Outlet Connection
Oxygen	R155-104	R155-105	R853S-83	R120-53
LPG	R155-104	R155-106	R853SY-83	R110-53
Acetylene	R155-104	R155-106	R853SY-83	R110-53

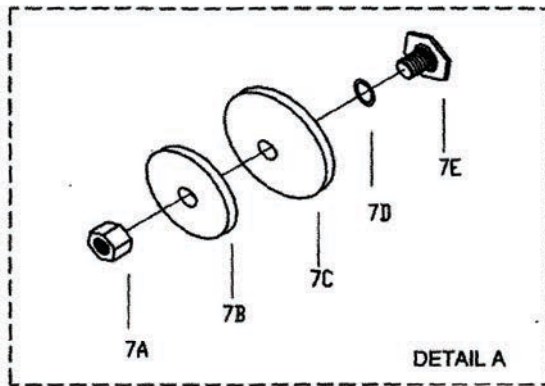
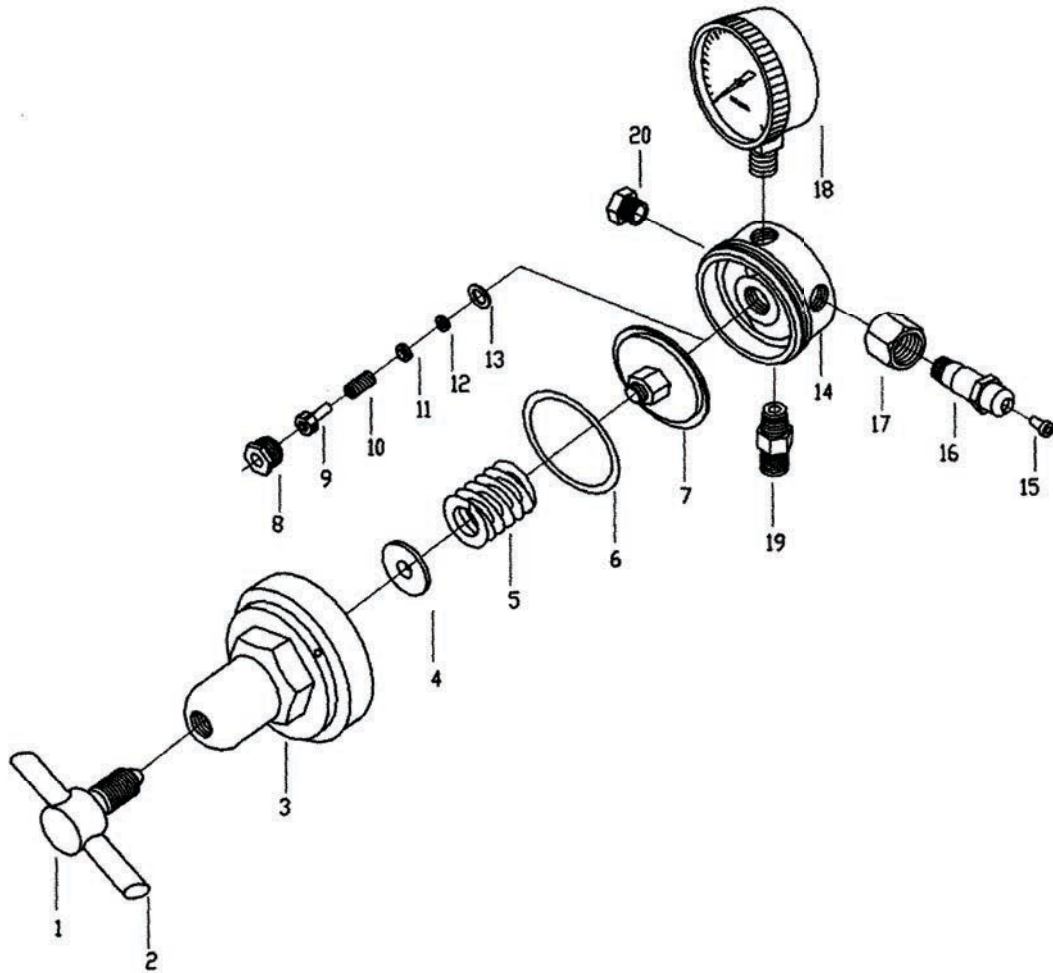

---

Ref. No.	Part Description	Part No.
1	Adjusting Screw	R853-01-01
2	Adjusting Stem	R853-01-02
3	Housing Cap	R853-04
4	Spring Button	R230-06
5	Adjusting Spring	See Chart 1
6	Slip Ring	R853-08
7	✦ Diaphragm Assembly	R853-82D
7A	Diaphragm Nut	R240-10
7B	Diaphragm Plate	R230-14
7C	Seal Washer	R130-15
7D	Diaphragm	R853-16
7E	Centralizer	R853-18
8	Nozzle	R150-30
9	✦ Seat Assembly	See Chart 2
10	Valve Spring	R150-35
11	Gland	R110-36
12	✦ Friction Washer	R110-37
13	✦ Gasket	R110-38
14	✦ Body	R853-50B
15	✦ Filter	R110-56
16	✦ Inlet Stem	See Chart 2
17	✦ Inlet Nut	See Chart 2
18	✦ L.P. Gauge	See Chart 1
19	✦ Outlet Connection	See Chart 2
20	Plug	RP-4HP

---

✦ Items most commonly required for regulator repair and recommended for stock.

Repair kits include these items.

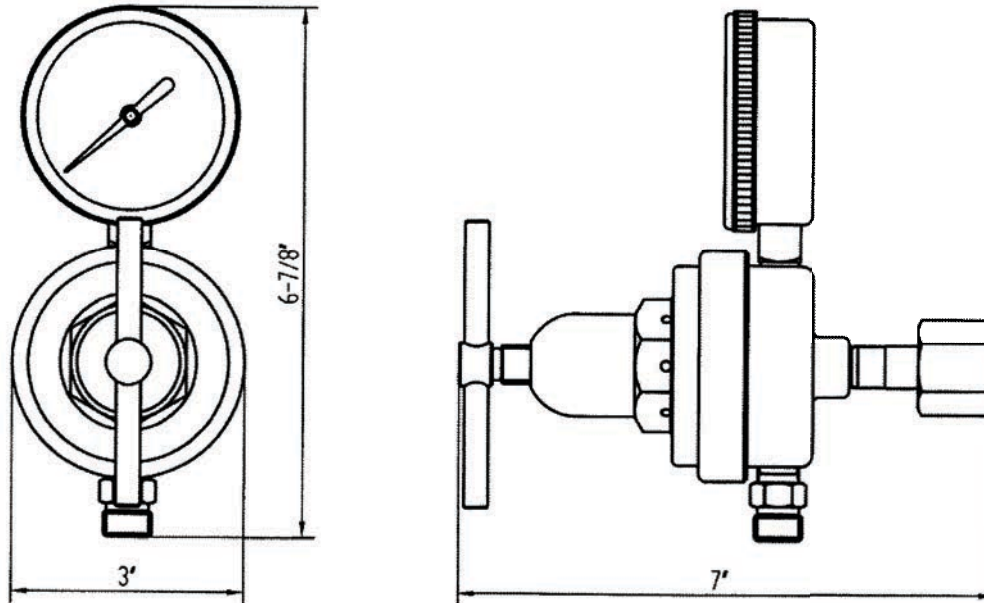

### MODEL INFORMATION

GAS SERVICE	MODEL NUMBER	MAX. DELIVERY PRESSURE (PSI)	INLET CONNECTION	OUTLET CONNECTION
L.P.G. GAS	853SRF-80	4-80	7/8"-14LH(F)	9/16"-18LH(M)
OXYGEN	853SRX-80	4-80	7/8"-14RH(F)	9/16"-18RH(M)
	853SRX-125	5-125	7/8"-14RH(F)	9/16"-18RH(M)
INERT GAS CO2	853SRIN-80	4-80	7/8"-14RH(M)	9/16"-18RH(F)
	853SRIN-125	5-125	7/8"-14RH(M)	9/16"-18RH(F)
ACETYLENE	853SRY-15	2-15	7/8"-14LH(F)	9/16"-18LH(M)

CHART 1

Description	853SRY-15	853SRF-80	853SRX-80 853SRIN-80	853SRX-125 853SRIN-125
Adjusting Spring	R130-07	R452X-07D	R452X-07D	R452N-07
L.P. Gauge	G25B-030RL	G25B-100	G25B-100	G25B-200

CHART 2

Gas Service	Inlet Stem	Inlet Nut	Seat Assembly	Outlet Connection
Oxygen	R155-104	R155-105	R853SR-83	R120-53
LPG	R155-104	R155-106	R853SRY-83	R110-53
Acetylene	R155-104	R155-106	R853SRY-83	R110-53
INERT GAS CO2	R120-58E	R120-57E	R853SR-83	R195-52

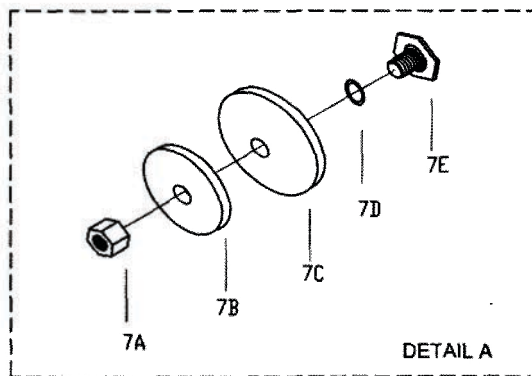
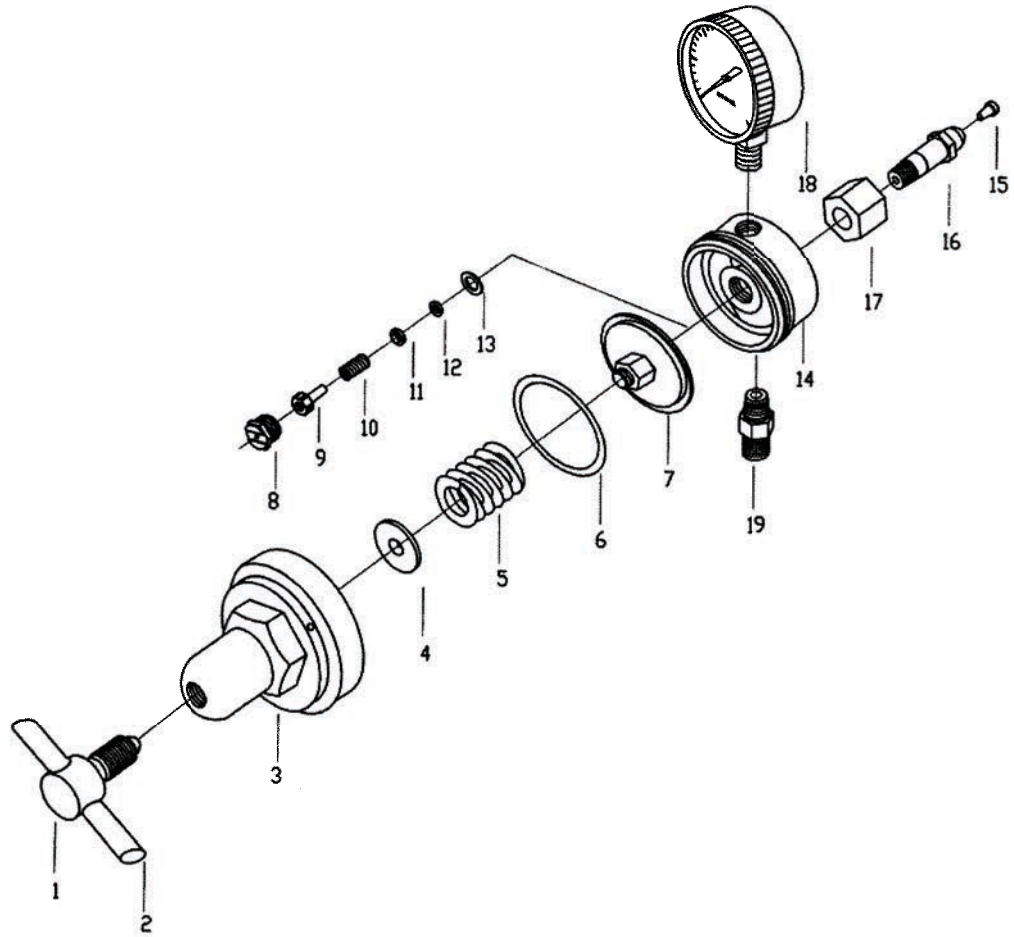

---

Ref. No.	Part Description	Part No.
1	Adjusting Screw	R853-01-01
2	Adjusting Stem	R853-01-02
3	Housing Cap	R853-04
4	Spring Button	R230-06
5	Adjusting Spring	See Chart 1
6	Slip Ring	R853-08
7	✦ Diaphragm Assembly	R853-82D
7A	Diaphragm Nut	R240-10
7B	Diaphragm Plate	R230-14
7C	Seal Washer	R130-15
7D	Diaphragm	R853-16
7E	Centralizer	R853-18
8	Nozzle	R150-30
9	✦ Seat Assembly	See Chart 2
10	Valve Spring	R150-35
11	Gland	R110-36
12	✦ Friction Washer	R110-37
13	✦ Gasket	R110-38
14	Body	R853-50A
15	✦ Filter	R110-56
16	Inlet Stem	See Chart 2
17	✦ Inlet Nut	See Chart 2
18	✦ L.P. Gauge	See Chart 1
19	✦ Outlet Connection	See Chart 2

---

✦ Items most commonly required for regulator repair and recommended for stock.

Repair kits include these items.



# **GENSTAR TECHNOLOGIES**

**4525 Edison Avenue, Chino, CA 91710, U.S.A.**

**Phone:909-606-2726 Fax:909-606-6485**

**[www.genstartech.com](http://www.genstartech.com)**

Product specifications are subject to change without notice.  
Copyright © 2005 Genstar Technologies Co., Inc.