



Medium Duty



Light Duty

# MANIPULATORS

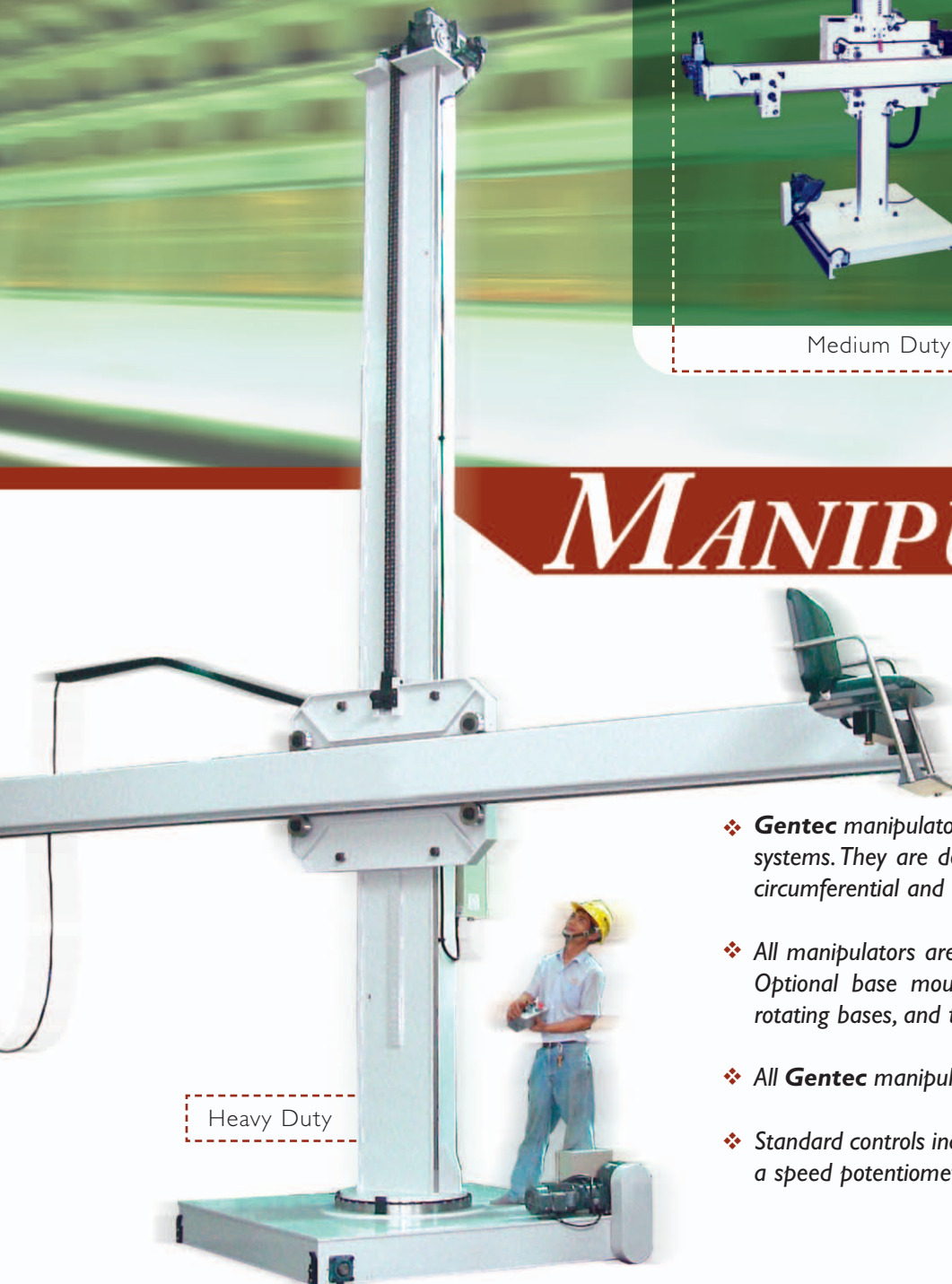

Heavy Duty

- ❖ *Gentec manipulators are durable precision automatic welding systems. They are designed to support process equipment for circumferential and longitudinal welding.*
- ❖ *All manipulators are available with standard bolt-down bases. Optional base mountings include free-standing bases, 360° rotating bases, and travel-car mounting bases.*
- ❖ *All **Gentec** manipulators are equipped with an anti-fall device.*
- ❖ *Standard controls include right/left horizontal travel switch with a speed potentiometer and rapid travel vertical motion.*

**OPTION**

**LIGHT DUTY**

- MP-201 Free standing base
- MP-202 Constant speed travel car
- MP-203 Track, 3M section for MP-202 travel car
- MP-204 360° base rotation
- MP-205 Variable speed travel car
- MP-206 Precision track, 3M section for MP-205 travel car
- MP-001 Support platform
- MP-002 Torch swivel, 0-180°

**MEDIUM DUTY**

- MP-401 Free standing base
- MP-402 Constant speed travel car
- MP-403 Track, 3M section for MP-402 travel car
- MP-404 360° base rotation
- MP-405 Variable speed travel car
- MP-406 Precision track, 3M section for MP-405 travel car
- MP-001 Support platform
- MP-002 Torch swivel, 0-180°

**HEAVY DUTY**

- MP-501 Free standing base
- MP-502 Constant speed travel car
- MP-503 Track, 3M section for MP-502 travel car
- MP-504 360° base rotation
- MP-505 Variable speed travel car
- MP-506 Precision track, 3M section for MP-505 travel car
- MP-001 Support platform
- MP-002 Torch swivel, 0-180°

**DIMENSION**

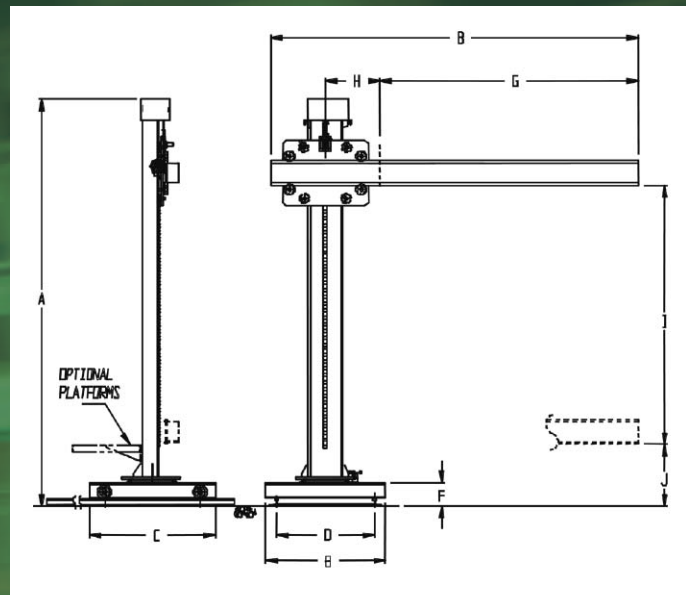

# MANIPULATORS

	UNIT	LIGHT DUTY		MEDIUM DUTY			HEAVY DUTY		
		MP-20L	MP-30L	MP-30M	MP-40M	MP-50M	MP-50H	MP-60H	MP-70H
POWER INPUT	-	3 PHASE 220/380V 50/60Hz OR 3 PHASE 460V 60Hz							
BOOM STROKE (G)	in	78	118	118	157	196	196	236	275
COLUMN STROKE (I)	in	78	118	118	157	196	196	236	275
BOOM DRIVE	hp	1/4		1/2			1/2		
BOOM LOAD ON ONE END	lb	330	220	660	440	220	660	440	220
BOOM LOAD ON BOTH END	lb	660	440	1300	880	441	1300	880	440
BOOM SPEED	in/min	10-98							
LIFT SPEED	in/min	45							
LIFT DRIVE	hp	1							
CAR SPEED (VARIABLE SPEED OPTION)	in/min	60(10-98)							
TRACK GAUGE (D)	in	43		57		82		82	
COLUMN ROTATION	deg	360		360			360		
OVERALL HEIGHT (A)	in	138	177	198	238	277	295	335	374
OVERALL WIDTH (B)	in	114	154	173	213	252	270	309	348
OVERALL LENGTH (C)	in	60	60	73	73	87	87	87	87
MIN. BOOM HEIGHT FROM FLOOR (J)	in	20		26			34		
MIN. BOOM DISTANCE FROM COLUMN (H)	in	20		28			37		
CAR WIDTH (E)	in	51		70		90	90		
CAR HEIGHT FROM FLOOR (F)	in	12		12		12	13		

**GENSTAR TECHNOLOGIES Co., Inc.**  
 4525 Edison Avenue  
 Chino, CA 91710  
 Tel: 909-606-2726  
 Fax: 909-606-6485

[www.genstartech.com](http://www.genstartech.com)