

GENSTAR TECHNOLOGIES COMPANY, INC.

WELDING POSITIONERS

MEDIUM & HEAVY DUTY
10 models range up to 45,000lb capacity

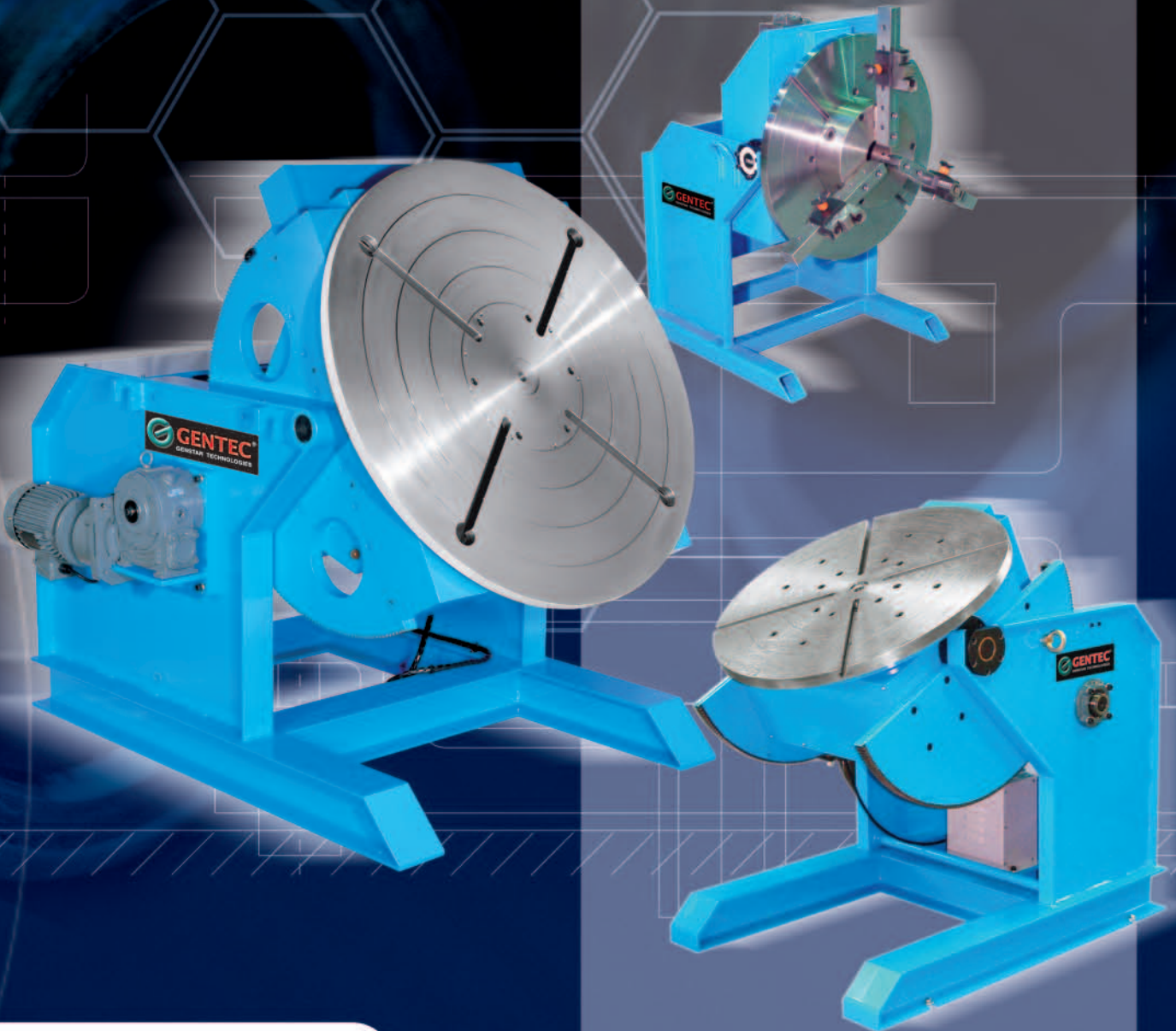

www.genstartech.com

 **GENTEC**[®]
GENSTAR TECHNOLOGIES

PT-750, PT-1500, PT-3000 & PT-5000 Series



PT-5000

Features:

PT-750

- Spindle has a 1" through hole
- 4 slots large turning table, quick mounting for various grippers
- All units are high frequency protected
- Powered tilt table
- Standard hand pendent control w/ ON/OFF foot control
- Optional adjustable table height* to fit larger workpiece
- Optional variable speed foot control

PT-1500, PT-3000 & PT-5000

- An all welded steel frame construction
- Large size machined table with 4 T-slots
- All units are high frequency protected
- Forward-Stop-Reverse and variable speed control are standard
- Standard hand pendent control and ON/OFF foot control
- Optional adjustable table height* to fit larger workpiece
- Optional variable speed foot control

Specification

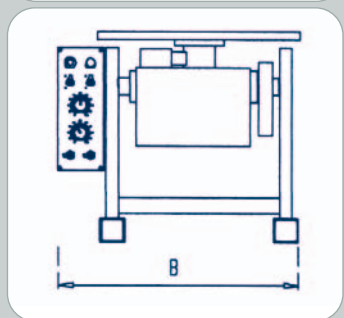
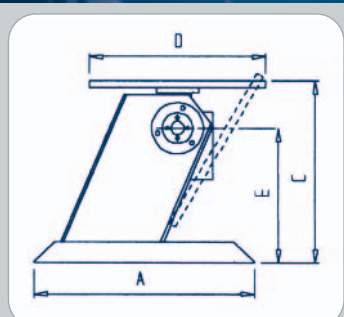

MODEL	UNIT	PT-750	PT-1500	PT-3000	PT-5000
SPECIFICATION					
Power Input	-	3 Phase 230/460V 60Hz			
Capacity (Horizontal / Vertical)	lb	1650/1100	3300	6600	11000
Rated Centre of Gravity	in	11.8	11.8	11.8	11.8
Rated Eccentricity	in	11.8	11.8	11.8	11.8
Table Dimension (D)	in	24	31.5	39	47
Rotation Speed	rpm	0.05-1.00	0.1-1	0.05-1	0.04-0.8
Spindle thru Hole	in	1	1.4	1.4	1.6
Table Slot Bolt Size	-	M12	M16	M20	M24
Earthing	amp	400	800	800	800
Rotation Motor	hp	1/4	1	2	3
Tilt Motor	hp	1/4	1/2	1	3
Tilt Range	deg	0-135	0-135	0-135	0-135
Tilt Speed (135 deg.)	sec	45	58	65	56
Overall Length (A)	in	40/42	55	67	79
Overall Width (B)	in	34.5	40	47	55
Overall Height (C)	in	28	39	43	47
Center to Floor (E)	in	23.5*(23.5~38.5)	33.5*(33.5~50.51)	37*(37~61)	39*(39~71)
Weight	lb	711/880	1716	2750	4400

Optional Accessories

Medium Duty

Welding Chucks:

PG-150, PG-500 & PG-750L



PG-150 3/16" - 6"



PG-500 3/16" - 19 1/2"



PG-750L 5/8" - 29 1/2"

SPECIFICATION	MODEL	UNIT	PG-150	PG-500	PG-750L
Inside Clamp Range		in	1.9-5.9	2.2-21.3	3.2-32.3
Outside Clamp Range		in	1.2-6.3	0.2-19.7	0.5-29.5
Mounting Holes B.C.D.		in	5.8	5.8	9.8
Screw Size		-	3-M10	3-M10	3-M10
Chuck Jaws		-	(3) Self-Centering		
Chuck Adjustment		-	Single Point Screw		
Jaws Attachment		-	Reversible	Reversible, Quickset Ball Lock Pin	
Recommended Positioner		-	PT-100/200	PT-100/200/450	PT-450/750/1500
Net Weight		lb	22	30	100

Pipe Dolly

SR1000 (Adjustable)



SPECIFICATIONS

- Diameter Range: 2" ~ 33"
- Roller Diameter: 8"
- Roller Width: 2"
- Net Weight: 46 lb
- Stroke: 5.9"
- Depth: 17"
- Width: 18"
- Wight Capacity: 2,200 lb

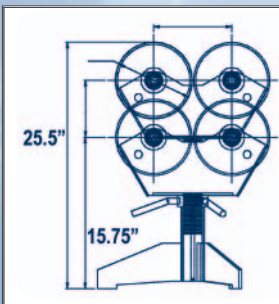

SR1000 Adjustable base 15.75" - 25.5"

	Minimum pipe dia.	Maximum pipe dia.
PT-450	2"	10.5"
PT-750	2"	14.5"
PT-1500	17.5"	33"
smaller size use spacers		

TR-0100I (Non-adjustable)

SPECIFICATIONS

- Pipe Diameter Range: 1" ~ 31"
- Weight Capacity: 1,100 lb

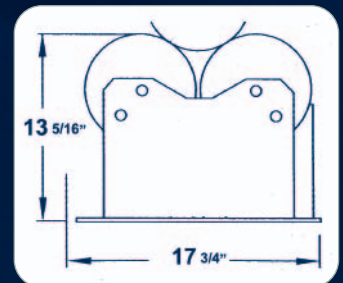

PT-10K, PT-15K & PT-20K Series

Heavy Duty

Features:

- An all welded steel frame construction
- Large size machined table with T-slotted table
- All units are high frequency protected
- Forward-Stop-Reverse and variable speed control are standard
- Optional adjustable table height* to fit larger workpiece
- Standard hand pendent control and ON/OFF foot control
- Optional variable speed foot control

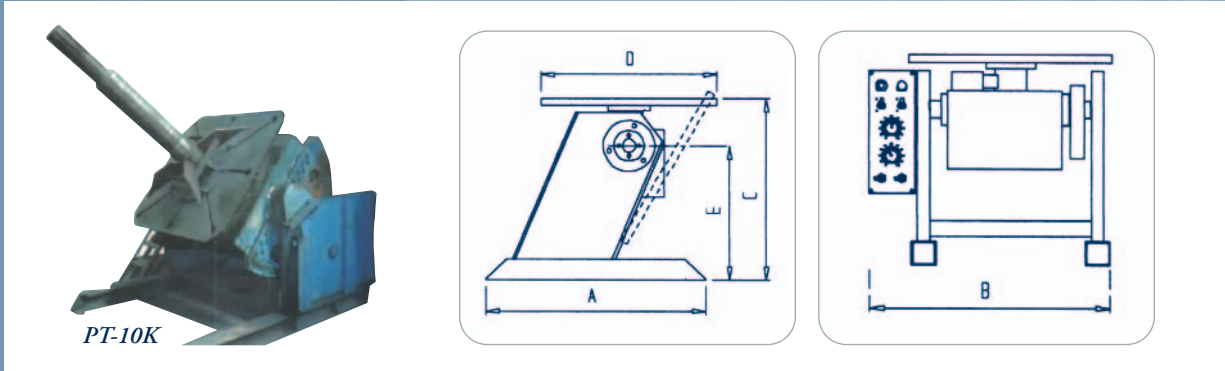

PT-10K

Specification

SPECIFICATION \ MODEL	UNIT	PT-10K	PT-15K	PT-20K
Power Input	-	3 Phase 230/460V 60Hz		
Capacity (Horizontal / Vertical)	lb	22,000	33,000	44,000
Rated Centre of Gravity	in	12	12	12
Rated Eccentricity	in	12	12	12
Table Dimension (D)	in	59	69	79
Rotation Speed	rpm	0.02-0.5	0.02-0.25	0.01-0.25
Spindle thru Hole	in	N/A	N/A	N/A
Table Slot Bolt Size	-	M30	M30	M30
Earthing	amp	800	800	800
Rotation Motor	hp	3	5	7.5
Tilt Motor	hp	5	7.5	10
Tilt Range	deg	0-135	0-135	0-135
Overall Length (A)	in	71	79	87
Overall Width (B)	in	71	83	94.5
Overall Height (C)	in	59	65	71
Center to Floor (E)	in	49*(49~81)	55*(55~95)	61*(61~100)
Weight	lb	9251	11674	14317

GENSTAR TECHNOLOGIES COMPANY, INC.
 4525 Edison Avenue
 Chino, CA 91710
 Phone | 909.606.2726
 Fax | 909.606.6485

www.genstartech.com