



INDUSTRIAL MANIFOLD SYSTEMS

Manifold Systems • Manifold Changeover Cabinet • Manifold Components

Technology for a Better Future



Company Overview

Genstar Technologies is a global leader in Gas Flow Control Systems for the industrial, specialty gas and medical sectors. We pride ourselves in our ability to provide our customers with high quality, value-added products and services that go beyond the industry standards. As a result, we have a global network of thousands of satisfied customers in over 60 countries.

Our Team

Our highly educated team of engineers, salespeople, technicians, managers, and customer service personnel are dedicated to providing you with products with the highest quality, reliability and performance. We hold the highest standards to our manufacturing processes; our total process management maximizes our production efficiency while ensuring product quality.

We work closely with all of our customers to design products specific to your needs. This includes developing new products, redesigning existing products, and customizing configuration / packaging. It is our priority to foster a strong relationship with each and every customer.

Quality Assurance

All of our products are manufactured under stringent quality control. We are ISO 9001:2001, ISO13485, and API certified. Our products meet UL, CE, SEMI, and various international standards and certifications.

Manufacturing Capabilities

The manufacturing facility is equipped with CNC machining centers, electropolishing equipment, and precision automatic orbital welding systems, among other features, to ensure the production of the highest quality products.

Clean Room Facilities

Our class 10/100/1000 clean rooms are designed for Ultra High Purity (UHP) products. UHP products undergo precision machining, surface finishing, electro-polishing and passivation. All UHP products are cleaned by 18MΩ DI water in a cascade ultrasonic tank.

To ensure the highest UHP product quality, they are then vacuum-dried and double-bagged.



Manifold Systems

- 02. Automatic Manifold Systems
- 04. Manifold Purchase Specifications Form
- 05. 5100 Series Dual Manifold Systems
- 06. 5200 Series Single-Bank Manifold Systems
- 08. 5300 Series Dual-Bank Manifold Systems
- 10. 5400 Series Semi-Automatic Manifold Systems
- 12. GM1 Series Dome Bias Semi-Automatic Manifolds
- 14. GM2-A Series Automatic Manifold Systems
- 16. GM2-D Series Digital Automatic Manifold Systems
- 18. 5600 Series Semi-Automatic Manifold Systems for Liquid Vessel
- 19. 5700AD Series Digital Automatic Manifold Systems for Liquid Vessels

Manifold Changeover Cabinet

- 21. Manifold Changeover Cabinet

Manifold Components

- 23. Manifold Piping & Header Extensions
- 24. Valves & Accessories, Manifold Components
- 25. Manifold Fittings
- 26. Pigtails, Wall Mounts, Pipe Holders and Pipe Supports
- 27. Flashback Arrestors & Pressure Switches & Pressure Transmitter
- 28. Gas Filter, Filter Elements, Gas Heater & Remote Alarm Panels
- 29. Gas Terminal Box, Station Drops, Terminal Gas Control Panel
- 30. Flashback Arrestors, Quick Connectors & Flowmeters
- 31. Manifold Regulators
- 33. Station & Line Regulators
- 35. Warranty Information
- 36. Cylinder Selection
- 37. Catalogs

1 Exhaust Port

- Easy for installation

2 Outlet

- 3/4" NPT for easy connection

3 Light And Control Buttons

- Status indicator
- Integral alarm buzzer
- Manual switch button for changeover

4 Pressure Gauge

- Multiple gauge unit option
- Work normally even in the event of power failure

5 Three-way Ball Valve

- Easy maintenance

6 Automatic Differential Pressure Type Switch Valve

- Patent design
- Double Solenoid valve control to initiate manifold switchover for uninterrupted gas supply

7 Control Circuit Board

- RS 485 communication and Dry Contact Output, can be integrated to a central monitoring system

8 Pressure Switches Pressure Transmitter

- 0-10V or 4 ~ 20 mA output
- Monitoring the outlet pressure and alarm for inlet pressure

9 Secondary Regulator

- High flow line regulator
- Per NFPA 99 requirements to allow for isolation and service of one while other is in use
- Available for on site repair
- Easy for maintenance

10 Ventilation Window

- Ventilation window on both sides of cabinet
- Well-ventilated to ensure safety

11 Primary Regulator

- Dome bias regulator technology
- Provide stable flow and durable
- Easy for maintenance

12 Relief Valve

- Relief pressures downstream of line regulators in order to prevent over pressurization.

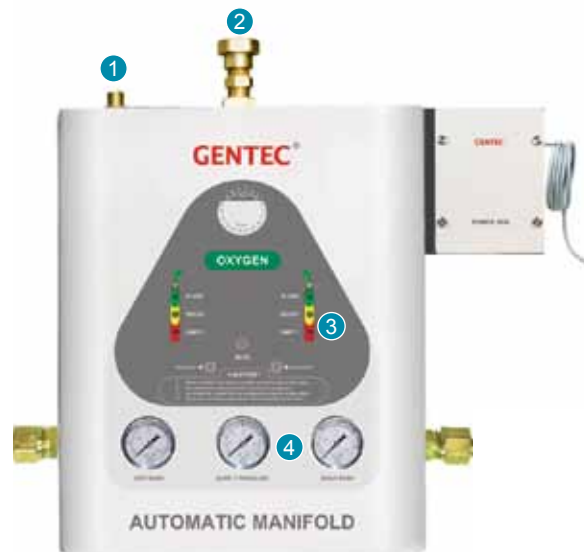



MANIFOLD PURCHASE SPECIFICATIONS FORM

Industrial Manifold Systems

- 1 Application of the manifold system: Industrial Specialty Gas Others
- 2 Gas service: Oxygen Acetylene Propane Air Carbon Dioxide (CO₂)
 Inert Gases (Argon, Nitrogen, Helium) Others
- 3 Type of manifold system required: Manual Semi-Automatic Automatic
- 4 Outlet pressure required: (psi)
- 5 Outlet flow rate required: (SCFH)
- 6 Type of mounting: Wall Mount Floor Mount
- 7 Cylinder Spacing (Center to Center): 5" 10" 13" 18"
- 8 Number of cylinders required: Left Bank Right Bank
- 9 Manifold system layout:

Series No Layout	5200 Series	5300/5400/5500/5500D Series	5600 Series
1 Standard Layout			
2 "L" shape Layout			
3 "U" shape Layout			
4 Crossover Layout			
5 Staggered Layout			

Manifolds Cylinder

10 Accessories:

- | | | |
|--------------------------|----------------|-----------|
| Pressure Switch | Model No. | Qty |
| Alarm System | Model No. | Qty |
| Gas Terminal (Pipeline) | Model No. | Qty |
| Gas Heater * | Model No. | Qty |
| Others | Model No. | Qty |

*Optional 500 SCFH heater is available for CO₂ & N₂O gas service with withdrawal rates above 35 SCFH / cylinder.

Note: Please fill out the above form so GENTEC can recommend the most suitable manifold system for your application.
 Please do not hesitate to contact us for more information.

5100 series dual manifold system is a simple gas delivery system which provides a maximum of 2 cylinders in service at one time . This non-extendable system is suitable for maintenance and gas applications where only one cylinder is in service at any given time and a manual changeover is required.

Features

- Silver brazing on piping joints for maximum leak prevention
- Individual Header Valves
- Headers have been tested to withstand high cylinder pressure
- Wall mount installation only

Standard Construction

- 24" flexible high pressure stainless steel braided pigtails* with check valve, Rigid copper pigtails are standard when gas service is oxygen. Pigtails for acetylene models are equipped with dry flashback arrestor.
- For Acetylene or Fuel gas model, regulator outlet is equipped with a dry flashback arrestor (FA30PF) for additional safety.
- Gentec's high flow regulator series 155M-A.
- Carbon Dioxide manifold systems are provided with 155CG electric heating regulator. Siphon cylinder should not be used in the manifold system.

* Refer to table on page 24 for pigtail information



Ordering Information

Series	Gas Service	Max. inlet Pressure psi (bar)	Delivery Pressure psi (bar)	Max. Delivery Flow SCFH (m³/h)	Outlet Connection	Pigtail Specifications
5100X	Oxygen	3000 (207)	10~200 (0.7~14)	3500 (100)	3/4" NPT (M)	Pigtail, CGA540
5100Y	Acetylene	400 (28)	2~15 (0.14~1)	700 (20)	3/4" NPT (M)	Pigtail, CGA510
5100F	Propane	400 (28)	5~125 (0.35~8.6)	1050 (30)	3/4" NPT (M)	Pigtail, CGA510
5100C	Carbon Dioxide	3000 (207)	5~125 (0.35~8.6)	2100 (60)	3/4" NPT (M)	Pigtail, CGA320
5100IN	Argon, Nitrogen, Helium	3000 (207)	10~200 (0.7~14)	3500 (100)	3/4" NPT (M)	Pigtail, CGA580
5100H	Hydrogen	3000 (207)	10~200 (0.7~14)	10500 (300)	3/4" NPT (M)	Pigtail, CGA350

Please specify the "model number" when ordering.
For example: 5100X indicates a dual "oxygen" manifold system.

5200 SERIES

Single-Bank Manifold Systems

Industrial Manifold Systems

5200 series Single-bank manifold system is designed for a single source of gas supply from one cylinder bank. Although this system can be used as a main delivery system, it is typically used in industrial and medical applications as a high pressure emergency back-up system for liquid vessel or bulk systems.

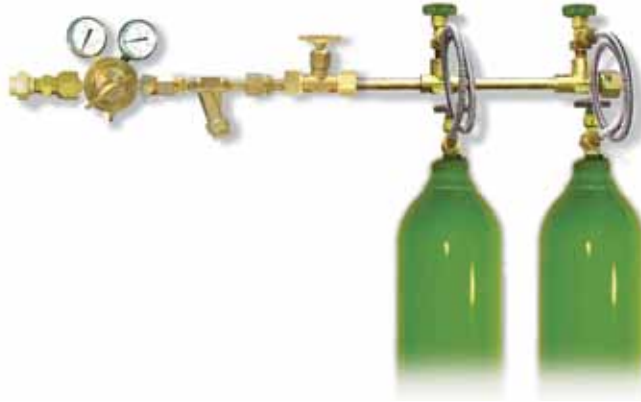

Features

- Open-style manifold
- System can be designed for right or left bank
- Silver brazing on piping joints for maximum leak prevention
- System is designed to accommodate future expansion needs
- System is mounted with gas filters
- Pressure switch port is available
- Headers have been tested to withstand high cylinder pressure
- Wall or floor mount available

Standard Construction

- 24" flexible high pressure stainless steel braided pigtails* with check valve, Rigid copper pigtails are standard when gas service is oxygen. Pigtails for acetylene models are equipped with dry flashback arrestor.
- For Acetylene or Fuel gas model, regulator outlet is equipped with a dry flashback arrestor (FA30PF) for additional safety. As an option, hydraulic flashback arrestors are available for an additional charge.
- Gentec's high flow regulator series 155M-A.
- Carbon Dioxide manifold systems are provided with 155CG electric heating regulator.
- Siphon cylinder should not be used in the manifold system.

* Refer to table on page 24 for pigtail information

Specifications

Series	Gas Service	Max. Inlet Pressure psi (bar)	Delivery Pressure psi (bar)	Max. Delivery Flow SCFH (m ³ /h)	Outlet Connection	Pigtail Specifications
5200X	Oxygen	3000 (207)	10~200 (0.7~14)	3500 (100)	3/4" NPT (M)	Pigtail, CGA540
5200Y	Acetylene	400 (28)	2~15 (0.14~1)	700 (20)	3/4" NPT (M)	Pigtail, CGA510
5200F	Propane	400 (28)	5~125 (0.35~8.6)	1050 (30)	3/4" NPT (M)	Pigtail, CGA510
5200C	Carbon Dioxide	3000 (207)	5~125 (0.35~8.6)	2100 (60)	3/4" NPT (M)	Pigtail, CGA320
5200IN	Argon, Nitrogen, Helium	3000 (207)	10~200 (0.7~14)	3500 (100)	3/4" NPT (M)	Pigtail, CGA580
5200Q	Air	3000 (207)	10~200 (0.7~14)	3500 (100)	3/4" NPT (M)	Pigtail, CGA590
5200H	Hydrogen	3000 (207)	10~200 (0.7~14)	10500 (300)	3/4" NPT (M)	Pigtail, CGA350

Installation Dimensions

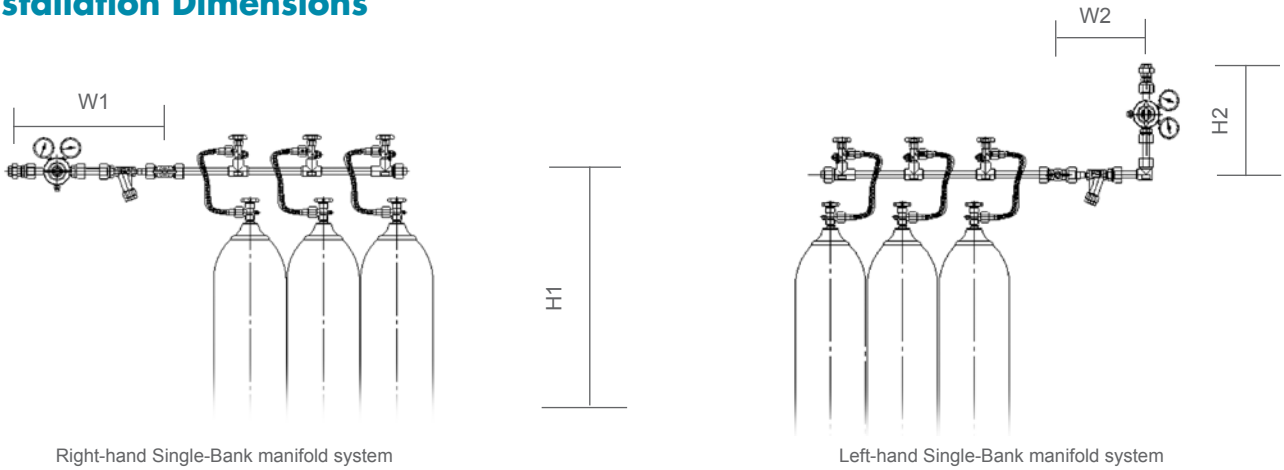

Gas Service	W1 in.(mm)	H1 in.(mm)	W2 in.(mm)	H2 in.(mm)
Oxygen, Air, Argon, Nitrogen	21.0 (534)	55.2 (1400)	12.3 (313)	14.6 (372)
Acetylene, Propane	27.8 (708)	51.2 (1300)	12.3 (313)	21.5 (546)
Carbon Dioxide	27.5 (698)	55.2 (1400)	18.8 (477)	14.6 (372)

Manifold System Layouts

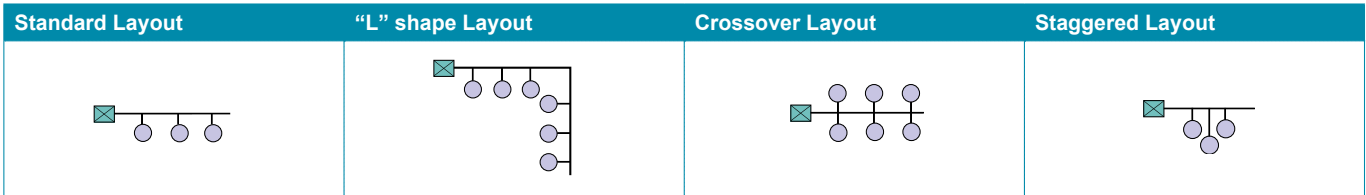

Ordering Information

52	1	2	X	- 3	R	- 1
Series	Manifold System Layout	Cylinder Valve Spacing	Gas Service	Number of Cylinders	Direction of Manifold Piping	Type of Mounting
Single-bank manifold system	1: Standard layout 2: "L" Shape layout 3: N/A 4: Crossover layout 5: Staggered layout	1: 5" (127 mm) 2: 10" (254 mm) 3: 13" (330 mm) 4: 18" (457 mm)	X: Oxygen Y: Acetylene F: Propane C: Carbon dioxide IN: Ar, He, N ₂ Q: Air H: Hydrogen	1: One cylinder 2: Two cylinders 3: Three cylinders ...	L: left R: right <i>Note: Direction of piping (Right or Left) is indicated by facing the manifold.</i>	1: Wall mount 2: Floor mount

Example: 5212X-3R-1 indicates a 3 cylinder right-hand Single-bank oxygen manifold system. Distance between each cylinder is 10" on standard horizontal layout.

5300 SERIES

Dual-Bank Manifold Systems

Industrial Manifold Systems

5300 series dual-bank manifold system consists of a main gas delivery bank and a reserve bank of cylinders. When the primary cylinder bank is depleted, manually “turn off” the valve on the primary bank and open the valve on the reserve bank to reactivate gas flow. The changeover of this system needs to be operated manually.



Features

- Open-style manifold
- Silver brazing on piping joints for maximum leak prevention
- System is designed to accommodate future expansion needs
- System is mounted with gas filters
- Pressure switch port is available
- Headers have been tested to withstand high cylinder pressure
- Wall or floor mount available

Standard Construction

- 24” flexible high pressure stainless steel braided pigtails* with check valve, Rigid copper pigtails are standard when gas service is oxygen. Pigtails for acetylene models are equipped with dry flashback arrestor.
- For Acetylene or Fuel gas model, regulator outlet is equipped with a dry flashback arrestor (FA30PF) for additional safety. As an option, hydraulic flashback arrestors are available for an additional charge.
- Gentec’s high flow regulator series 155M-A.
- Carbon Dioxide manifold systems are provided with 155CG electric heating regulator. Siphon cylinder should not be used in the manifold system.

* Refer to table on page 24 for pigtail information

Specifications

Series	Gas Service	Max. Inlet Pressure psi (bar)	Delivery Pressure psi (bar)	Max. Delivery Flow SCFH (m ³ /h)	Outlet Connection	Pigtail Specifications
5300X	Oxygen	3000 (207)	10~200 (0.7~14)	3500 (100)	3/4” NPT (M)	Pigtail, CGA540
5300Y	Acetylene	400 (28)	2~15 (0.14~1)	700 (20)	3/4” NPT (M)	Pigtail, CGA510
5300F	Propane	400 (28)	5~125 (0.35~8.6)	1050 (30)	3/4” NPT (M)	Pigtail, CGA510
5300C	Carbon Dioxide	3000 (207)	5~125 (0.35~8.6)	2100 (60)	3/4” NPT (M)	Pigtail, CGA320
5300IN	Argon, Nitrogen, Helium	3000 (207)	10~200 (0.7~14)	3500 (100)	3/4” NPT (M)	Pigtail, CGA580
5300Q	Air	3000 (207)	10~200 (0.7~14)	3500 (100)	3/4” NPT (M)	Pigtail, CGA590
5300H	Hydrogen	3000 (207)	10~200 (0.7~14)	10500 (300)	3/4” NPT (M)	Pigtail, CGA350

Installation Dimensions

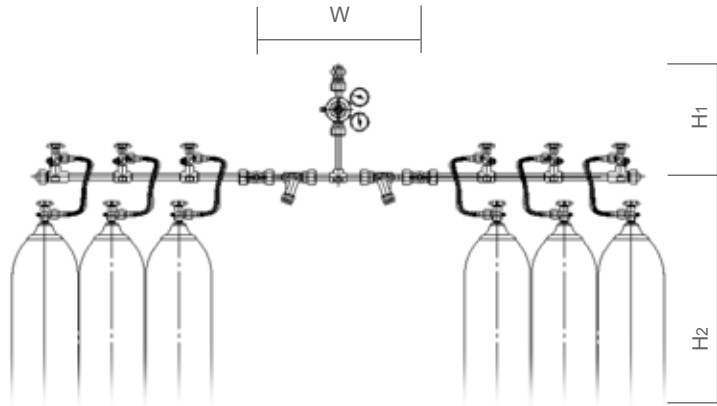

Gas Service	W1 in.(mm)	H1 in.(mm)	H2 in.(mm)
Oxygen, Air, Argon, Nitrogen	25.3 (642)	19.2 (488)	55.1 (1400)
Acetylene, Propane	25.3 (642)	26.1 (662)	51.2 (1300)
Carbon Dioxide	25.3 (642)	25.7 (652)	55.1 (1400)

Manifold System Layouts

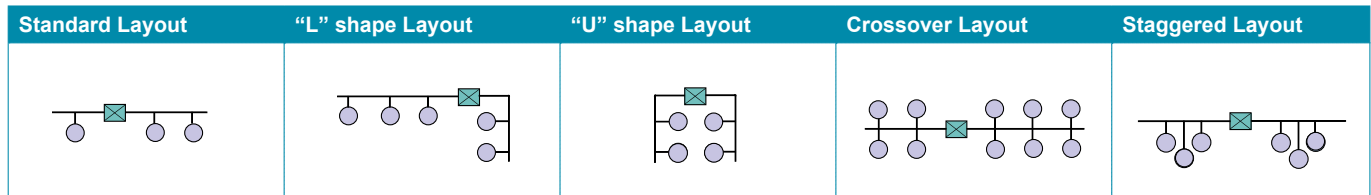

Ordering Information

53	1	2	X	- 5 x 5	- 1
Series	Manifold System Layout	Cylinder Valve Spacing	Gas Service	Number of Cylinders (left-hand / right-hand)	Type of Mounting
Dual-bank manifold system	1: Standard layout 2: “L” Shape layout 3: “U” shape layout 4: Crossover layout 5: Staggered layout	1: 5” (127 mm) 2: 10” (254 mm) 3: 13” (330 mm) 4: 18” (457 mm)	X: Oxygen Y: Acetylene F: Propane C: Carbon Dioxide IN: Ar, He, N ₂ Q: Air H: Hydrogen	1 x 2: One cylinder on the left, Two cylinders on the Right 5 x 5: Five cylinders on the left, Five cylinders on the Right ... <i>Note: Direction of piping (Right or Left) is indicated by facing the manifold.</i>	1: Wall mount 2: Floor mount

Example: 5312X-5x5-1 indicates a 5 x 5 cylinder dual-bank manifold system.
Distance between two cylinders is 10” on standard horizontal layout.

5400 SERIES

Semi-Automatic Manifold Systems

Industrial Manifold Systems

5400 series semi-automatic manifold system is designed to provide an uninterrupted gas supply. It consists of a primary bank and a reserve bank of cylinders. When the pressure in the primary cylinder bank reduces to the pre-set value, the changeover takes place automatically to provide continuous supply of gas from the reserve bank. Upon changing the cylinders, the regulators on both banks need to be re-adjusted in order for the changeover to occur automatically next time. The secondary regulator in the main pipeline stabilizes the outlet gas flow.

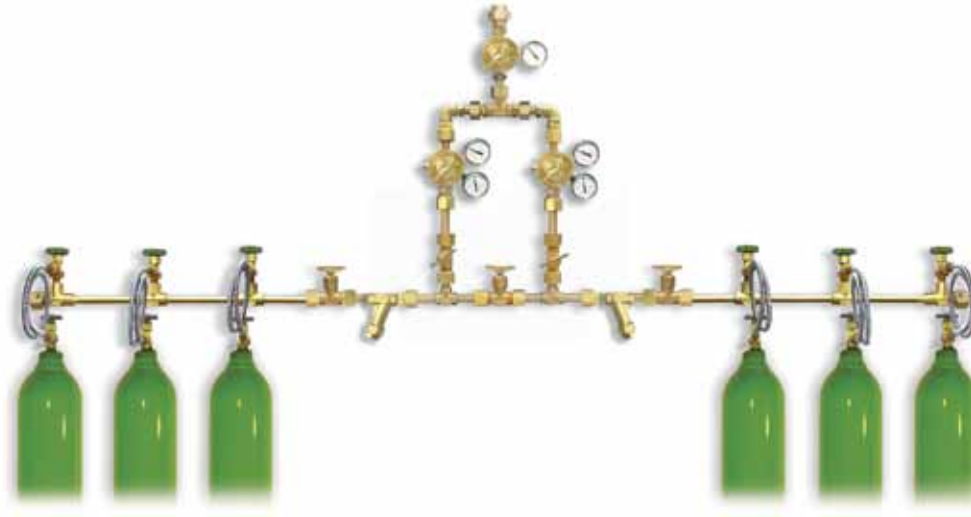

Features

- Open-style manifold
- Secondary regulator for consistent high flow delivery pressure to the pipeline
- Silver brazing on piping joints for maximum leak prevention
- System is designed to accommodate future expansion needs
- System is mounted with gas filters
- Unique changeover valve provides uninterrupted supply of gas from primary and reserve banks
- Pressure switch port is available
- Headers have been tested to withstand high cylinder pressure
- Wall or floor mount available

Standard Construction

- 24" flexible high pressure stainless steel braided pigtails* with check valve, Rigid copper pigtails are standard when gas service is oxygen. Pigtails for acetylene models are equipped with dry flashback arrestor.
- For Acetylene or Fuel gas model, regulator outlet is equipped with a dry flashback arrestor (FA30PF) for additional safety. As an option, hydraulic flashback arrestors are available for an additional charge.
- Gentec's high flow regulator series 155L (except for acetylene) & 155M-A.
- Carbon Dioxide manifold systems are provided with 155CG electric heating regulator. Siphon cylinder should not be used in the manifold system.

* Refer to table on page 24 for pigtail information

Specifications

Series	Gas Service	Max. Inlet Pressure psi (bar)	Delivery Pressure psi (bar)	Max. Delivery Flow SCFH (m ³ /h)	Outlet Connection	Pigtail Specifications
5400X	Oxygen	3000 (207)	10~200 (0.7~14)	3500 (100)	3/4" NPT (M)	Pigtail, CGA540
5400Y	Acetylene	400 (28)	2~15 (0.14~1)	700 (20)	3/4" NPT (M)	Pigtail, CGA510
5400F	Propane	400 (28)	5~125 (0.35~8.6)	1050 (30)	3/4" NPT (M)	Pigtail, CGA510
5400C	Carbon Dioxide	3000 (207)	5~125 (0.35~8.6)	2100 (60)	3/4" NPT (M)	Pigtail, CGA320
5400IN	Argon	3000 (207)	10~200 (0.7~14)	1750 (50)	3/4" NPT (M)	Pigtail, CGA580
	Helium	3000 (207)	10~200 (0.7~14)	7000 (200)	3/4" NPT (M)	Pigtail, CGA580
	Nitrogen	3000 (207)	10~200 (0.7~14)	3500 (100)	3/4" NPT (M)	Pigtail, CGA580
5400Q	Air	3000 (207)	10~200 (0.7~14)	3500 (100)	3/4" NPT (M)	Pigtail, CGA590
5400H	Hydrogen	3000 (207)	10~200 (0.7~14)	10500 (300)	3/4" NPT (M)	Pigtail, CGA350

Installation Dimensions

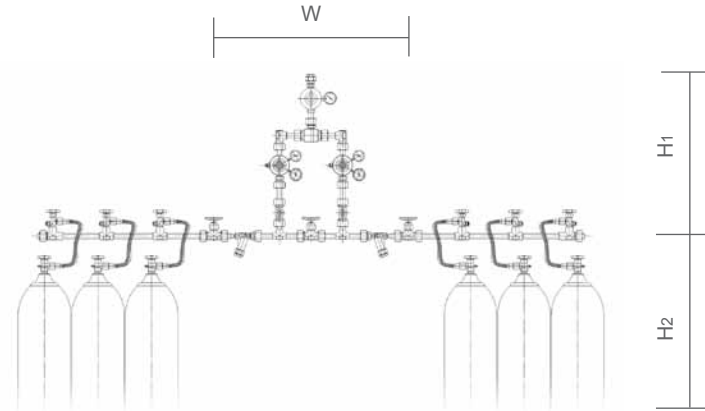

Gas Service	W1 in.(mm)	H1 in.(mm)	H2 in.(mm)
Oxygen, Air, Argon, Nitrogen, Helium	35.9 (912)	29.1 (739)	55.1 (1400)
Acetylene, Propane	35.9 (912)	36.9 (912)	51.2 (1300)
Carbon Dioxide	48.8 (1240)	29.1 (739)	55.1 (1400)

Manifold System Layouts

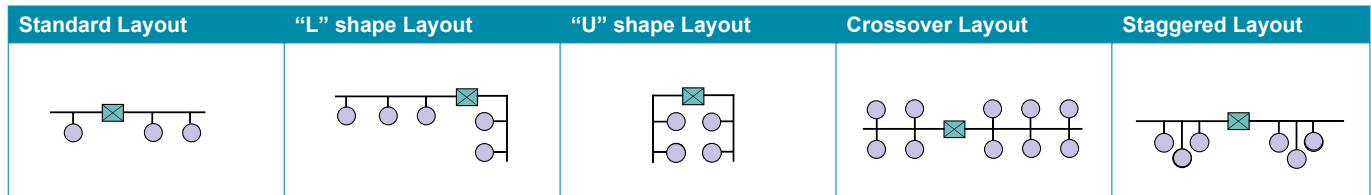

Ordering Information

54	1	2	X	- 5 x 5	- 1
Series	Manifold System Layout	Cylinder Valve Spacing	Gas Service	Number of Cylinders (left-hand / right-hand)	Type of Mounting
Semi-automatic manifold system	1: Standard layout 2: “L” Shape layout 3: “U” shape layout 4: Crossover layout 5: Staggered layout	1: 5” (127 mm) 2: 10” (254 mm) 3: 13” (330 mm) 4: 18” (457 mm)	X: Oxygen Y: Acetylene F: Propane C: Carbon Dioxide IN: Ar, He, N ₂ Q: Air H: Hydrogen	1 x 2: One cylinder on the left, Two cylinders on the Right 5 x 5: Five cylinders on the left, Five cylinders on the Right ... <i>Note: Direction of piping (Right or Left) is indicated by facing the manifold.</i>	1: Wall mount 2: Floor mount

Example: 5412X-5x5-1 indicates a 5 x 5 cylinder semi-automatic manifold system.
Distance between two cylinders is 10” on standard horizontal layout.

GM1 series dome-bias semi-automatic manifold system is designed to provide an uninterrupted gas supply. It consists of a primary bank and a reserve bank of cylinders. When the pressure in the primary cylinder bank reduces to the preset value, the changeover takes place automatically to provide continuous supply of gas from the reserve bank. The priority handle should be manually switched during cylinder change.



Features

Semi-automatic Changeover System

- Fully enclosed, dust-proof metal cabinet
- Pressure gauge indicates gas source and outlet pressure
- Secondary regulator for consistent pressure and flow delivery to the pipeline
- Relief valve at outlet for protecting downstream piping
- Pressure switch port is available
- Mechanical dome-bias changeover design
- Prior indicator valve
- Suitable for high flow systems; rated for 120m³/h (4200SCFH)* to 170m³/h (6000 SCFH)**

* When delivery pressure is 50 psi

** When delivery pressure is 180 psi

Pipeline

- Silver brazing on piping joints for maximum leak prevention
- System is designed to accommodate future expansion needs
- Optional external filter provides easy replacement of filter element
- Optional master shutoff valves
- Headers have been tested to withstand high cylinder pressure
- Wall or floor mount available

Standard Construction

- 24" or 36" flexible high pressure stainless steel braided pigtails with check valve
- Rigid copper pigtails are standard when gas service is oxygen
- Carbon Dioxide manifold systems are provided with H900G electric gas heater
- Siphon-type cylinder should not be used in the manifold system

Specifications

Series	Gas Service	Max. Inlet Pressure psi (bar)	Delivery Pressure psi (bar)	Max. Delivery Flow SCFH (m ³ /h)	Outlet Connection	Pigtail Specifications
GM1-AL-O2	Oxygen	3000 (207)	10~145 (0.69~10)	4200 (120)	3/4" NPT (M)	Pigtail, CGA540
GM1-AM-IN	Inert Gas	3000 (207)	10~230 (0.69~15.86)	6000 (170)	3/4" NPT (M)	Pigtail, CGA510
GM1-AM-CO2	Carbon Dioxide	2175(150)	4.4~125 (0.3~8.62)	1060 (30)	3/4" NPT (M)	Pigtail, CGA510
GM1-AH-AIR	AIR	3000 (207)	10~203 (0.69~14)	5300 (150)	3/4" NPT (M)	Pigtail, CGA320

Installation Dimensions

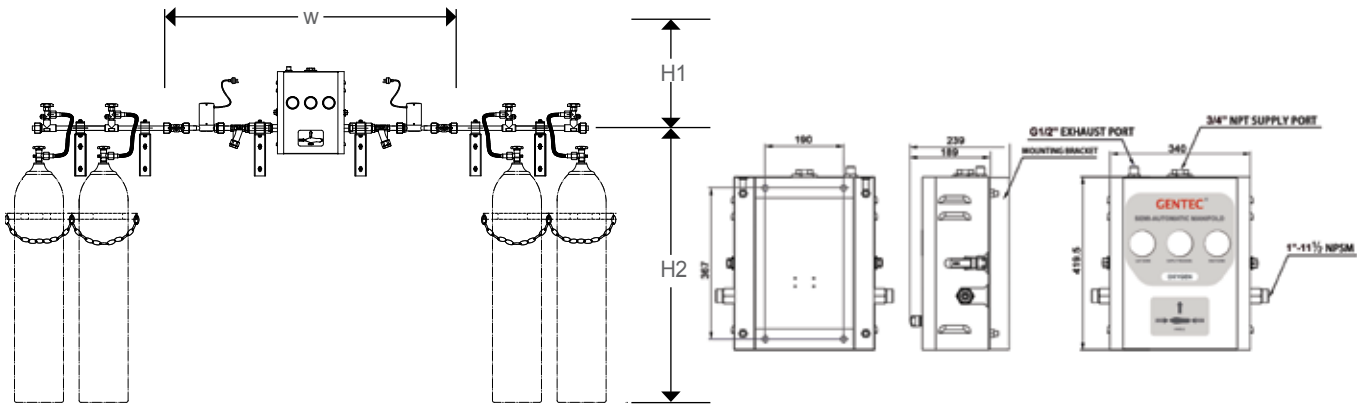

Gas Service	W in.(mm)	H1 in.(mm)	H2 in.(mm)
Oxygen, Air, Argon, Nitrogen, Helium	41.3 (1050)	15.8 (400)	55.1 (1400)
Carbon Dioxide	56.3 (1430)	15.8 (400)	55.1 (1400)

Manifold System Layouts

Standard Layout	"L" shape Layout	"U" shape Layout	Crossover Layout	Staggered Layout

Ordering Information

Series	Delivery Pressure	Gas Service	Standard Code	Number of Cylinders (left-hand / right-hand)	Manifold System Layout	Cylinder Valve Spacing
GM1-A	USA (ISO) L: 55 psi (0.5 MPa) M: 100 psi (0.8 MPa) H: 185 psi (1 MPa) EN Standard L: 72.5 psi (5 bar) M: 116 psi (8 bar) H: 145 psi (10 bar)	O2: Oxygen AIR: Air CO2: Carbon Dioxide IN: Argon, Helium, Nitrogen	U: NFPA 99 (USA) E: ISO 32	1L-2R: One cylinder on the left, Two cylinders on the Right 5L-5R: Five cylinders on the left, Five cylinders on the Right ...	S: Standard layout L: "L" Shape layout U: "U" shape layout D: Crossover layout X: Staggered layout	1: 5" (127 mm) 2: 10" (254 mm) 3: 13" (330 mm) 4: 18" (457 mm)

Example: GM1-AL-O2-U-(5x5-S2) indicates a 5*5 oxygen cylinder automatic manifold system. Distance between two cylinders is 10" on standard horizontal layout.
 GM1-AL-O2-U-(0x0) indicates an oxygen changeover system with filters and master shutoff valves.
 GM1-AL-O2-U indicates an oxygen changeover system only.

GM2-A SERIES

Automatic Manifold Systems

Industrial Manifold Systems

GM2-A series automatic manifold system is designed to provide an uninterrupted gas supply without any manual adjustments. This system automatically changes over when the primary cylinder bank is depleted. Even in case of power failure, the system continues to supply gas without interruption.



Features

Automatic Changeover Cabinet

- Fully enclosed, tamper-resistant metal cabinet
- Light indicators provide system status
- Systems for fuel gas come with an anti-explosive device
- External filter facilitates replacement of filtration elements

Header

- Silver brazing on piping joints for maximum leak prevention
- System is designed to accommodate future expansion needs
- System is mounted with gas filters
- Pressure switch port available
- Headers have been tested to withstand high cylinder pressure
- Wall or floor mount available

Standard Construction

- 24" flexible high pressure stainless steel braided pigtails* with check valve, Rigid copper pigtails are standard when gas service is oxygen. Pigtails for acetylene models are equipped with dry flashback arrestor.
- For Acetylene or Fuel gas model, regulator outlet is equipped with a dry flashback arrestor (FA30PF) for additional safety. As an option, hydraulic flashback arrestors are available for an additional charge.
- Carbon Dioxide manifold systems are provided with H900G electric heating regulator. Siphon cylinder should not be used in the manifold system.

Specifications

Series	Gas Service	Max. Inlet Pressure psi (bar)	Delivery Pressure psi (bar)	Max. Delivery Flow SCFH (m ³ /h)	Outlet Connection	Pigtail Specifications
GM2-AL-O2	Oxygen	3000 (207)	10~200 (0.7~14)	3500 (100)	3/4" NPT (M)	Pigtail, CGA540
GM2-AL-Y	Acetylene	400 (28)	2~15 (0.14~1)	700 (20)	3/4" NPT (M)	Pigtail, CGA510
GM2-AL-F	Propane	400 (28)	5~125 (0.35~8.6)	1050 (30)	3/4" NPT (M)	Pigtail, CGA510
GM2-AM-CO2	Carbon Dioxide	3000 (207)	5~125 (0.35~8.6)	1050 (30)	3/4" NPT (M)	Pigtail, CGA320
GM2-AM-IN	Argon, Helium, Nitrogen	3000 (207)	10~200 (0.7~14)	3500 (100)	3/4" NPT (M)	Pigtail, CGA580

Installation Dimensions

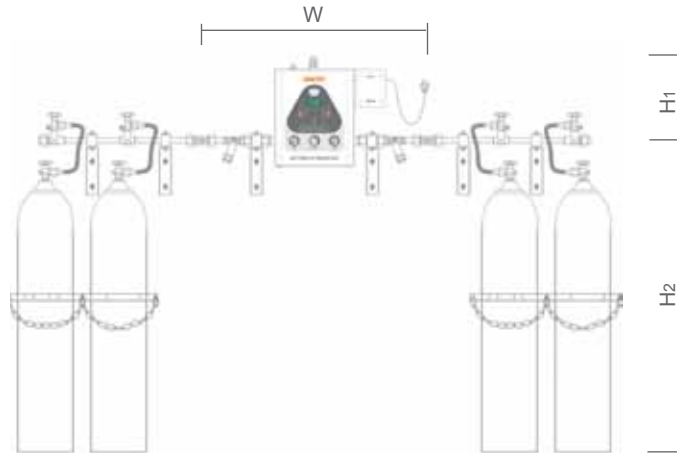

Gas Service	W in.(mm)	H1 in.(mm)	H2 in.(mm)
Oxygen, Air, Argon, Nitrogen, Helium	41.3 (1050)	15.8 (400)	55.1 (1400)
Acetylene, Propane	59.8 (1520)	21.7 (550)	55.1 (1400)
Carbon Dioxide	55.5 (1410)	15.8 (400)	55.1 (1400)

Manifold System Layouts

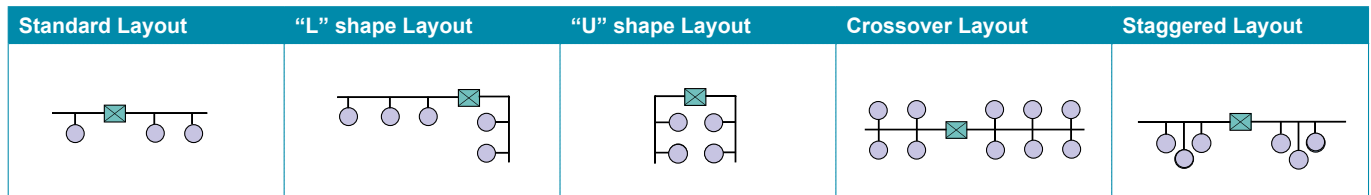

Ordering Information

GM2-A	L	- O2	- U	- (5L - 5R	- S	2)
Series	Delivery Pressure	Gas Service	Standard Code	Number of Cylinders (left-hand / right-hand)	Manifold System Layout	Cylinder Valve Spacing
automatic manifold system (Pressure Gauge)	USA (ISO) L: 55 psi (0.5 MPa) M: 100 psi (0.8 MPa) H: 185 psi (1 MPa)	O2: Oxygen AIR: Air N2O: Nitrous Oxide CO2: Carbon Dioxide IN: Argon, Helium, Nitrogen	U: USA Standards E: ISO Standards UE: Canada Standards	1L-2R: One cylinder on the left, Two cylinders on the Right 5L-5R: Five cylinders on the left, Five cylinders on the Right ... <i>Note: Direction of piping (Right or Left) is indicated by facing the manifold.</i>	S: Standard layout L: “L” Shape layout U: “U” shape layout D: Crossover layout X: Staggered layout	1: 5” (127 mm) 2: 10” (254 mm) 3: 13” (330 mm) 4: 18” (457 mm)

Example: GM2-AL-O2-U-(5x5-S2) indicates a 5*5 oxygen cylinder automatic manifold system. Distance between two cylinders is 10” on standard horizontal layout.
 NFPA99 color code (USA)
 GM2-AL-O2-U-(0x0) indicates an oxygen changeover system with filters and master shutoff valves. NFPA99 color code (USA)
 GM2-AL-O2-U indicates an oxygen changeover system only. NFPA99 color code (USA)

GM2-D SERIES

Digital Automatic Manifold Systems

Industrial Manifold Systems

GM2-D series digital automatic manifold system is designed to provide an uninterrupted gas supply. The fully automatic digital manifold system monitors cylinder bank pressure electronically, automatically changes over to secondary bank when the primary cylinder bank is depleted, and eliminates the need to manually set a priority side. In case of power failure, the system continues to supply gas without interruption. Using our second generation pressure differential switchover valve and newly designed manifold regulators boosts the flowrate and reliability of the system.



Features

Automatic Changeover Cabinet

- Fully enclosed, tamper-resistant metal cabinet
- On-site Display: Indicator lights of system status, Gauge Pressures, visual Remote alarm box provide system status; Digital display of pressure; with changeover alarm function
- Pressure switch control
- External filter facilitates replacement of filtration elements
- Patent pending changeover technology

Header

- Silver brazing on piping joints for maximum leak prevention
- System is designed to accommodate future expansion needs
- System is mounted with gas filters
- Pressure switch port available
- Headers have been tested to withstand high cylinder pressure
- Wall or floor mount available

Standard Construction

- 24" flexible high pressure stainless steel braided pigtails* with check valve, Rigid copper pigtails are standard when gas service is oxygen. Pigtails for acetylene models are equipped with dry flashback arrestor.
- For Acetylene or Fuel gas model, regulator outlet is equipped with a dry flashback arrestor (FA30PF) for additional safety. As an option, hydraulic flashback arrestors are available for an additional charge.
- Carbon Dioxide manifold systems are provided with H900DG electric heating regulator. Siphon cylinder should not be used in the manifold system.

Specifications

Series	Gas Service	Max. Inlet Pressure psi (bar)	Delivery Pressure psi (bar)	Max. Delivery Flow SCFH (m ³ /h)	Outlet Connection	Pigtail Specifications
GM2-DL-O2	Oxygen	3000 (207)	10~200 (0.7~14)	3500 (100)	3/4" NPT (M)	Pigtail, CGA540
GM2-DL-Y	Acetylene	400 (28)	2~15 (0.14~1)	700 (20)	3/4" NPT (M)	Pigtail, CGA510
GM2-DL-F	Propane	400 (28)	5~125 (0.35~8.6)	1050 (30)	3/4" NPT (M)	Pigtail, CGA510
GM2-DM-CO2	Carbon Dioxide	3000 (207)	5~125 (0.35~8.6)	1050 (30)	3/4" NPT (M)	Pigtail, CGA320
GM2-DM-IN	Argon, Helium, Nitrogen	3000 (207)	10~200 (0.7~14)	3500 (100)	3/4" NPT (M)	Pigtail, CGA580

Installation Dimensions

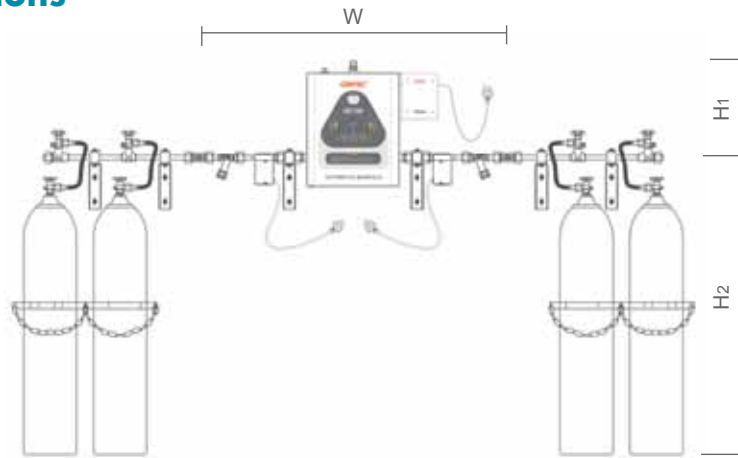

Gas Service	W in.(mm)	H1 in.(mm)	H2 in.(mm)
Oxygen, Air, Argon, Nitrogen, Helium	41.3 (1050)	15.8 (400)	55.1 (1400)
Acetylene, Propane	59.8 (1520)	21.7 (550)	55.1 (1400)
Carbon Dioxide	55.5 (1410)	15.8 (400)	55.1 (1400)

Manifold System Layouts

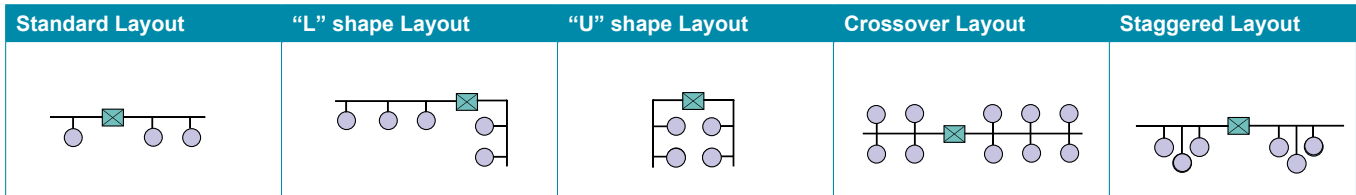

Ordering Information

GM2-D	L	- O2	- U	- (5L - 5R	- S	2)
Series	Delivery Pressure	Gas Service	Standard Code	Number of Cylinders (left-hand / right-hand)	Manifold System Layout	Cylinder Valve Spacing
automatic manifold system (Digital)	USA (ISO) L: 55 psi (0.5 MPa) M: 100 psi (0.8 MPa) H: 185 psi (1 MPa)	O2: Oxygen AIR: Air N2O: Nitrous Oxide CO2: Carbon Dioxide IN: Argon, Helium, Nitrogen	U: USA Standards E: ISO Standards UE: Canada Standards	1L-2R: One cylinder on the left, Two cylinders on the Right 5L-5R: Five cylinders on the left, Five cylinders on the Right ...	S: Standard layout L: “L” Shape layout U: “U” shape layout D: Crossover layout X: Staggered layout	1: 5” (127 mm) 2: 10” (254 mm) 3: 13” (330 mm) 4: 18” (457 mm)

Example: GM2-DL-O2-U-(5x5-S2) indicates a 5*5 oxygen cylinder automatic manifold system. Distance between two cylinders is 10” on standard horizontal layout.
 NFPA99 color code (USA)
 GM2-DL-O2-U-(0x0) indicates an oxygen changeover system with filters and master shutoff valves. NFPA99 color code (USA)
 GM2-DL-O2-U indicates an oxygen changeover system only. NFPA99 color code (USA)

5600 SERIES

Semi-Automatic Manifold Systems for Liquid Vessel

Industrial Manifold Systems

5600 series manifold system is designed specifically for liquid vessels to provide an uninterrupted gas supply. When the primary liquid vessel is depleted, the changeover takes place automatically to provide continuous supply of gas from the reserve liquid vessel. Upon changing the vessel, the regulators on both banks need to be re-adjusted in order for the changover to occur automatically next time.



Features

- Semi-automatic changeover control
- Unique changeover valve provides uninterrupted supply of gas from primary and reserve vessels
- The whole system is pressure resistance tested
- Wall mount available

Ordering Information

Please specify the “model number” when ordering.

Example: “5600C” indicates semi-automatic manifold system for liquid vessels.

Series	Gas Service	Max. Inlet Pressure psi (bar)	Delivery Pressure psi (bar)	Max. Delivery Flow SCFH (m ³ /h)	Outlet Connection	Pigtail Specifications
5600C	Carbon Dioxide	435 (30)	5~125 (0.35~8.6)	1050 (30)	3/4" NPT (M)	Pigtail, CGA320
5600IN	Argon	435 (30)	5~125 (0.35~8.6)	1750 (50)	3/4" NPT (M)	Pigtail, CGA580
	Helium	435 (30)	5~125 (0.35~8.6)	5250 (150)	3/4" NPT (M)	Pigtail, CGA580
	Nitrogen	435 (30)	5~125 (0.35~8.6)	3150 (90)	3/4" NPT (M)	Pigtail, CGA580

Note: The flow rate depends on the vaporization rate of gas supplied.

5700A series automatic manifold system is designed specifically for cryogenic vessels to provide an uninterrupted gas supply without any manual operation. This system automatically changes over when the primary bank is depleted. Even in case of power failure, the system continues to operate without interruption.



Features

Automatic Changeover Cabinet

- Fully enclosed, tamper-resistant metal cabinet
- Light indicators provide system status, with changeover alarm function
- Gas saving structure reduces gas consumption in the reserve cylinder, safe and economical
- Pressure switch valve control
- External filter provides easy replacement of filtration element

Header

- Silver brazing on piping joints for maximum leak prevention
- System is designed to accommodate future expansion needs
- System is mounted with gas filters
- Pressure switch port available
- Headers have been tested to withstand high cylinder pressure
- Wall or floor mount available

Ordering Information

Series	Gas Service	Max. Inlet Pressure psi (bar)	Delivery Pressure psi (bar)	Max. Delivery Flow SCFH (m³/h)	Outlet Connection	Pigtail Specifications
5700AX	Oxygen	435 (30)	5~125 (0.35~8.6)	2500 (70)	3/4" NPT (M)	Pigtail, CGA540
5700AC	Carbon Dioxide	435 (30)	5~125 (0.35~8.6)	1050 (30)	3/4" NPT (M)	Pigtail, CGA320
5700AIN	Argon	435 (30)	5~125 (0.35~8.6)	1750 (50)	3/4" NPT (M)	Pigtail, CGA580
	Helium	435 (30)	5~125 (0.35~8.6)	5250 (150)	3/4" NPT (M)	Pigtail, CGA580
	Nitrogen	435 (30)	5~125 (0.35~8.6)	3150 (90)	3/4" NPT (M)	Pigtail, CGA580

Note: The flow rate depends on the vaporization rate of gas supplied.

5700AD SERIES

Digital Automatic Manifold Systems for Liquid Vessel

Industrial Manifold Systems

5700AD series digital automatic manifold system is designed specifically for cryogenic vessels to provide an uninterrupted gas supply without any manual operation. This system automatically changes over when the primary bank is depleted. Even in case of power failure, the system continues to operate without interruption.



Features

Automatic Changeover Cabinet

- Fully enclosed, tamper-resistant metal cabinet
- On-site Display: Indicator lights of system status, Gauge Pressures, visual Remote alarm box provide system status; Digital display of pressure; with changeover alarm function
- Pressure switch control
- External filter provides easy replacement of filtration element Patent pending changeover technology

Header

- Silver brazing on piping joints for maximum leak prevention
- System is designed to accommodate future expansion needs
- System is mounted with gas filters
- Pressure switch port available
- Headers have been tested to withstand high cylinder pressure
- Wall or floor mount available

Ordering Information

Please specify the “model number” when ordering.

Example: “5700ADX” indicates automatic digital manifold system for liquid vessels.

Series	Gas Service	Max. Inlet Pressure psi (bar)	Delivery Pressure psi (bar)	Max. Delivery Flow SCFH (m ³ /h)	Outlet Connection	Pigtail Specifications
5700ADX	Oxygen	435 (30)	5~90 (0.35~6.2)	2500 (70)	3/4" NPT (M)	Pigtail, CGA540
5700ADC	Carbon Dioxide	435 (30)	5~90 (0.35~6.2)	1050 (30)	3/4" NPT (M)	Pigtail, CGA320
5700ADIN	Argon	435 (30)	5~90 (0.35~6.2)	1750 (50)	3/4" NPT (M)	Pigtail, CGA580
	Helium	435 (30)	5~90 (0.35~6.2)	6350 (180)	3/4" NPT (M)	Pigtail, CGA580
	Nitrogen	435 (30)	5~90 (0.35~6.2)	2800 (80)	3/4" NPT (M)	Pigtail, CGA580

Note: The flow rate depends on the vaporization rate of gas supplied.

Single-Bank Changeover System

Designed for Single-Bank cylinder manifold systems (right or left).

- Inlet connection thread: 1-11 1/2NPS RH(M)
- Outlet connection thread: 3/4" NPT(M)
- Max. Inlet Pressure: 3000 psi for Oxygen, Carbon Dioxide, Argon, Nitrogen, Helium, Air; 400 psi for Acetylene, Propane

Model Number	Gas Service	Description
5200X-00L	Oxygen	Left Bank
5200X-00R	Oxygen	Right Bank
5200YD-00L	Acetylene	Left Bank With FA (FA30PF)
5200YD-00R	Acetylene	Right Bank With FA (FA30PF)
5200FD-00L	Propane	Left Bank With FA (FA30PF)
5200FD-00R	Propane	Right Bank With FA (FA30PF)
5200FH-00R	Propane	Left Bank With FA (GFA-1000 LPG)
5200C-00L	Carbon Dioxide	Left Bank With Gas Heater
5200C-00R	Carbon Dioxide	Right Bank With Gas Heater
5200IN-00L	Argon, Nitrogen, Helium	Left Bank
5200IN-00R	Argon, Nitrogen, Helium	Right Bank
5200Q-00L	Air	Left Bank
5200Q-00R	Air	Right Bank
5200H-00L	Hydrogen	Left Bank
5200H-00R	Hydrogen	Right Bank



5200X-00L



5200X-00R

Dual-Bank Changeover System

- Designed for dual-bank manifold systems
- Inlet connection thread: 1"-11-1/2NPS RH (M)

Model Number	Gas Service	Accessories
5300X-00	Oxygen	
5300YD-00	Acetylene	With FA (FA30PF)
5300FD-00	Acetylene	With FA (FA30PF)
5300C-00	Carbon Dioxide	With Gas Heater
5300IN-00	Argon, Nitrogen, Helium	
5300H-00	Hydrogen	



5300X-00

MANIFOLD CHANGEOVER CABINET

Manifold Changeover Cabinet

Industrial Manifold Systems

Semi-automatic changeover manifold systems

Designed for semi-automatic changeover manifold systems.

- Inlet connection thread: 1-11 1/2NPS RH(M)
- Outlet connection thread: 3/4" NPT(M)
- Max. Inlet Pressure: 3000 psi for Oxygen, Carbon Dioxide, Argon, Nitrogen, Helium, Air; 400 psi for Acetylene, Propane

Model Number	Gas Service	Accessories
5400X-00	Oxygen	
5400YD-00	Acetylene	With FA (FA30PF)
5400FD-00	Propane	With FA (FA30PF)
5400C-00	Carbon Dioxide	With Gas Heater
5400IN-00	Argon, Nitrogen, Helium	
5400Q-00	Air	
5400H-00	Hydrogen	



5400X-00

Automatic changeover Cabinet

- Suitable for automatic manifold changeover system. Even in case of power failure, the system continues to operate without interruption
- Detachable rollover cabinet cover, easy to maintain and service
- Three-way gas pressure display
- The panel shows the system working status
- Two-stage regulator construction for stable gas delivery
- High accuracy pressure switch control
- Wall mount available
- Inlet connection thread: 1"-11-1/2NPS(M) Outlet connection thread: Rc 3/4"
- Safety Discharge Port: G 3/4"
- Electrical setting: Operating voltage 220VAC, insulation between strong and weak current
- Dimensions: 20"(W) x 24"(H) x 8"(D) (508mm x 610mm x 203mm)



5500X-00

Model Number	Gas Service	Max. Inlet Pressure psi (bar)	Delivery Pressure psi (bar)	Max. Delivery Flow SCFH (m³/h)	Accessories
5500X-00	Oxygen	3000 (207)	10~145 (0.7~10)	3500 (100)	-
5500IN-00	Argon	3000 (207)	10~145 (0.7~10)	3150 (90)	-
	Helium	3000 (207)	10~145 (0.7~10)	8800 (250)	-
	Nitrogen	3000 (207)	10~145 (0.7~10)	3700 (105)	-
	Carbon Dioxide	3000 (207)	10~145 (0.7~10)	1400 (40)	With Gas Heater
5500EYD-00	Acetylene	435 (30)	2~15 (0.14~1)	500 (15)	With FA (FA30PF)
5500EYH-00	Acetylene	435 (30)	2~15 (0.14~1)	700 (20)	With FA (GFA-1000A)
5500EFD-00	Propane	435 (30)	5~125 (0.35~8.6)	1050 (30)	With FA (FA30PF)
5500EFH-00	Propane	435 (30)	5~125 (0.35~8.6)	700 (20)	With FA (GFA-1000A)

Manifold Piping

Header extension consists of a gas delivery pipe and header valves. It is expandable for different application requirements.

- Machined with class "A" brass stock
- Silver brazing on piping joints for maximum leak prevention
- Maximum working pressure: 3000 psi
- Inlet (Header valve): Fuel Gas-CGA 510
Other gases-CGA540
- Outlet :1"-11-1/2NPS

GHER-310X

Right-hand manifold piping



GHNS-310X

Single valve per header block for straight configuration



GHEL-310X

Left-hand manifold pipings



GHND-310X

Dual Valves per header block for staggered configuration



GHEC-310X

Dual manifold pipings



GHNQ-102X

Quad Valves per header block for space saving



Ordering Information

Please follow the instructions below to select the correct model number.

Example: GHER-210X indicates a right-hand oxygen manifold piping system with 2 joints, and 10" joint distance.

GH	E	R	- 3	10	X
Series	Valve Type	Piping Shape & Layout joints	No. of Joints	Joints Spacing	Gas Service
GH	E: Globe Valve	R: Right-hand manifold pipings L: Right-hand manifold pipings C: Dual manifold pipings	2: Two Joints 3: Three Joints 4: Four Joints 5: Five Joints ...	02: 1.5" (40 mm) 05: 5" (127 mm) 10: 10" (254 mm) 13: 13" (330 mm) 18: 18" (457 mm) <i>(Does not apply to "C" Piping Shape.)</i>	X: Oxygen Y: Acetylene F: Propane C: Carbon Dioxide IN: Argon, Nitrogen, Helium Q: Air
	N: Check valve	S: Single joint manifold pipings D: Dual joints manifold pipings Q: Quad joints manifold pipings			

Header Extensions

Model Number	Length	Inlet Connection	Outlet Connection	Description
GEE-4	4-1/2"	1"-11-1/2NPS-RH (M)	1"-11-1/2NPS-RH (F)	Elbow
GEE-8	8-1/3"	1"-11-1/2NPS-RH (M)	1"-11-1/2NPS-RH (F)	
GEE-11	11-1/3"	1"-11-1/2NPS-RH (M)	1"-11-1/2NPS-RH (F)	
GET-9X	8-2/3"	1"-11-1/2NPS-RH (F)	1"-11-1/2NPS-RH (F)	"T" shape
GCC-4	4"	1"-11-1/2NPS-RH (F)	1"-11-1/2NPS-RH (F)	Extension
GCC-4L	4"	1"-11-1/2NPS-RH (F)	1"-11-1/2NPS-LH (F)	



MANIFOLD COMPONENTS

Valves & Components

Industrial Manifold Systems

Valves & Accessories

Model Number	Inlet / Outlet Connection	Gas Service	Description
GMV-180	1"-11-1/2NPS	*All Gas	Master Valve
GMV-90X	CGA540 / 1/2" NPT	O ₂ , CO ₂ , Air, Ar, He, N ₂	Header Valve
GMV-90F	CGA510 / 1/2" NPT	C ₂ H ₂ , C ₃ H ₈ , H ₂	
GMV-91X	1/2" NPT / G5/8-RH	O ₂ , CO ₂ , Air, Ar, He, N ₂	In-line Check Valve
GMV-91F	1/2" NPT / G5/8-LH	C ₂ H ₂ , C ₃ H ₈ , H ₂	
B-RV95-T350-NT4	1/4"NPT	*All Gas	Relief Valve, Set Pressure: 3 50 psi
B-RV95-T280-NT4	1/4"NPT	*All Gas	Relief Valve, Set Pressure: 280 psi
B-RV95-T150-NT4	1/4"NPT	*All Gas	Relief Valve, Set Pressure: 150 psi
B-RV95-F80-NT4	1/4"NPT	*All Gas	Relief Valve, Set Pressure: 80 psi
B-BV312-NT8	1/4"NPT	*All Gas	3-Way Ball Valve, Work Pressure: 450 psi

*All gases = non-corrosive gases

Model Number	Description
R155-103	1/2"NPT
R155-103A	1/4"NPT
R155-103B	3/4"NPT
R155-111	Adaptor, 1/4"NPT(M) / 1"-11-1/2NPS-RH(M)
R155-111A	Adaptor, 1/4"NPT(M) / 1"-11-1/2NPS-LH(M)
R155-110	Adaptor, 1/2"NPT(M) / 1"-11-1/2NPS-RH(M)
GHER-210-02	Retaining Nut, 27/32"-20UNS(F)
GCC-A	Adaptor, 3/4"NPT(M) / 1"-11-1/2NPS-RH(M)
GCC-C	Adaptor, 3/4"NPT(M) / 1"-11-1/2NPS-LH(M)
GCC-B	Adaptor, 3/4"NPT(M) / 3/4"NPT(M)
GCC-D	Adaptor, 3/4"NPT(M) / 1/2"NPT(M)
EN-100A	Plug
GHFN-X	Nut, 1"-11-1/2NPS-RH(F)



GMV-180



GMV-90X



B-RV95-T350-NT4



B-BV312-NT8



R155-103A



R155-103



GHER-210-02



GCC-A



EN-100A



GHFN-X



GHFA-J1

Manifold Components

- Machined with class "A" brass stock Maximum working pressure: 20 MPa
- D: 22.5mm, ID: 11.5mm

Length	1/2" NPT	1/2"
1-1/2" (38mm)	GHBP-1A	-
2" (51mm)	GHBP-2A	GHBP-2C
4" (102mm)	GHBP-4A	GHBP-4C
6" (152mm)	GHBP-6A	GHBP-6C
8-1/2" (216mm)	GHBP-8A	GHBP-8C
11-1/2" (292mm)	GHBP-11A	GHBP-11C
6' (1829mm)	-	GHBP-180C
12' (3658mm)	-	GHBP-360C

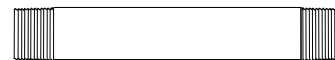

- Machined with class "A" brass stock
- Maximum working pressure: 3000 psi

Three-way connector

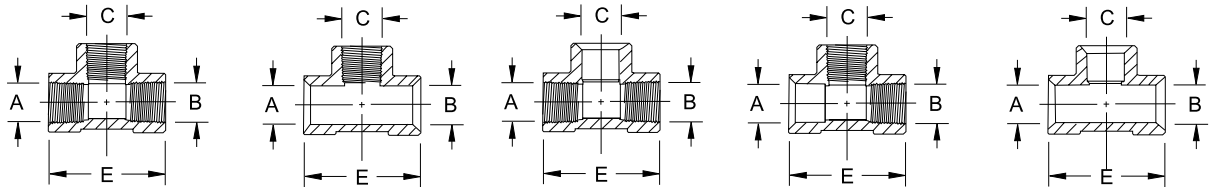

Model Number	A	B	C	E	Figure
GHFT-1A	1/2" NPT	1/2" NPT	1/2" NPT	2-1/2"	1
GHFT-1B	0.873-0.886	0.873-0.886	1/2" NPT	2-1/2"	2
GHFT-1C	1/2" NPT	1/2" NPT	0.873-0.886	2-1/2"	3
GHFT-1D	0.873-0.886	1/2" NPT	1/2" NPT	2-1/2"	4
GHFT-1E	0.873-0.886	0.873-0.886	0.873-0.886	2-1/2"	5

Four-way connector

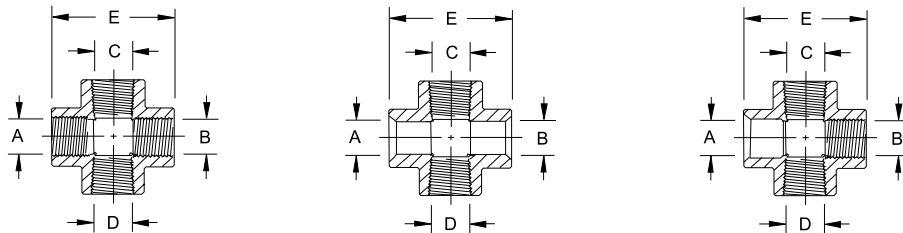

Model Number	A	B	C	D	E	Figure
GHFC-1A	1/2" NPT	1/2" NPT	1/2" NPT	1/2" NPT	2-3/4"	1
GHFC-1B	0.873-0.886	0.873-0.886	1/2" NPT	1/2" NPT	2-3/4"	2

Elbow Connector

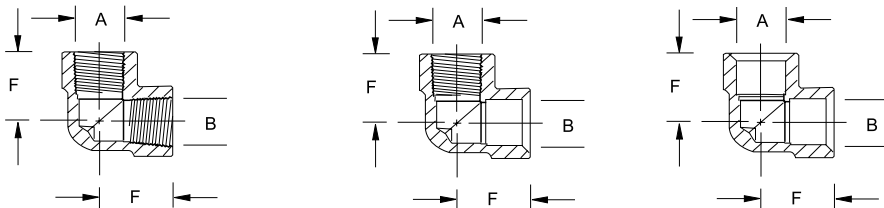

Model Number	A	B	E	Figure
GHFE-1A	1/2" NPT	1/2" NPT	1-1/4"	1
GHFE-1B	1/2" NPT	0.873-0.886	1-1/4"	2
GHFE-1C	0.873-0.886	0.873-0.886	1-1/4"	3

MANIFOLD COMPONENTS

Pigtails / Wall Mounts / Pipe Holders / Pipe Supports

Industrial Manifold Systems

High Pressure Pigtails

For use with GENTEC manifold systems only.



Copper pigtail



Stainless steel flexible pigtail

GPF -	24	CVO -	C540 -	510		
Model Number	Length	CV / FA	Connection (Cylinder)	Connection (Manifold)	Gas Service	Gas Not Recommended
GPF: Flexible pigtail (Teflon-lined)	24: 24" (610 mm) 36: 36" (914 mm) 59: 59" (1500 mm) 79: 79" (2000 mm)	Blank: Without check valve CVO: Check valve at manifold header side	C320: CGA320 (CO2) C326: CGA 326 (N2O) C346: CGA 346 (Air) C350: CGA 350 (C2H2) C510: CGA 510 (C2H2, Low Pressure) C540: CGA 540 (O2)	510: CGA 510 (Fuel Gas) 540: CGA 540 (Inert Gas)	Strong oxidizing Strong corrosive gas	High Pressure Medical Oxygen*
GPS: Stainless steel flexible pigtail (316SST) pigtail(316SST) pigtail(316SST)		CVI: Check valve at cylinder valve side FA: With flashback arrestor	C580: CGA 580 (Inert Gas) BS02: BS341 No 2 (C2H2) BS03: BS341 No 3 (Air, O2, N2, Inert Gas) BS04: BS341 No 4 (H2,CH4) BS08: BS341 No 8 (CO2) BS13: BS341 No 13 (N2O) DN1: DIN 477 No 1 (H2, C2H6, C2H4, Fuel Gas) DN3: DIN 477 No 3 (C2H2) DN6 : DIN 477 No 6 (Ar, CO2, Inert Gas) DN8: DIN 477 No 8 (N2O) DN10: DIN 477 No 10 (N2)		Fuel gas Non fuel gas	High Pressure Oxygen**
GPR: Copper rigid pigtail					Oxygen	Acetylene

* According to HTM, high pressure medical oxygen is not compatible with Teflon lining pigtail.
** High pressure oxygen should not be used with stainless steel pigtail according to relevant standards.

Cylinder Wall Mounts, Pipe Holders, and Pipe Supports

Model Number	Description
GMB-1	Single Cylinder Wall Mount, OD. 9" (229 mm)
GMB-2	Single Cylinder Wall Mount, OD. 14" (356 mm)
GMB-3	Dual Cylinder Wall Mount, OD. 9" (229 mm)
GMB-4	Dual Cylinder Wall Mount, OD. 14" (356 mm)
GMB-7	Mounting Bracket
GMB-9B	Header Support



GMB-7



GMB-9B



GMB-1



GMB-3

Hydraulic Flashback Arrestors

Hydraulic Flash Arrestor is designed for use on Acetylene or Fuel Gas Manifold Systems to protect the main gas supply from the dangers of reverse flow and flashbacks. A pressure relief valve is included to provide additional protection from excessive pressure. (Inlet and outlet connection thread : G1")

Model Number	Gas Service	Delivery Flow (SCFH)
GFA-1000A	Acetylene	990
GFA-1000LPG	Propane, LPG	990
GFA-300A	Acetylene	300
GFA-300LPG	Propane, LPG	300



GFA-300A

In-line Low Pressure Flashback Arrestors

Designed for use on Acetylene or Fuel Gas Manifold Systems with low pressure piping system to protect the main gas supply from the dangers of reverse flow and flashbacks by stainless steel sintered elements and check valves.



FA30PO



FA33SP



HFA43SP

Model Number	Gas Service	Working Pressure psi (bar)	Delivery Flow (SCFH)	Inlet / Outlet Connection
FA30PF	Acetylene, Propane	22 (1.5)	2450	3/4" NPT(F) / 3/4" NPT(F)
FA30PO	Oxygen	145 (10)	5800	3/4" NPT(F) / 3/4" NPT(F)
FA33SP	Hydrogen	50 (3.5)	1250	1/4" NPT(F) / 1/4" NPT(M)
HFA43SP	Hydrogen	145 (10)	4100	3/8" NPT(F) / 3/8" NPT(F)
	Propane	115 (8)	900	3/8" NPT(F) / 3/8" NPT(F)

Pressure Switches

Pressure switches are designed for gas manifold systems to activate remote alarm systems. Operates when cylinder/line pressure is below minimum pressure setting.



GHPS-4E
Explosion-Proof



GHPS-1
Regular

Model Number	Pressure Range psi (bar)	Max. Inlet Pressure psi (bar)	Pressure Connection
GHPS-1	5~50 (0.35~3.5)	440 (30)	1/8" NPT
GHPS-2	30~600 (2.1~41.5)	2200 (152)	1/8" NPT
GHPS-3	100~1500 (6.9~103)	2200 (152)	1/4" NPT
GHPS-4E	0.01~0.07 (1.5~10)	4.14 (600)	1/4" NPT (F)
GHPS-5E	0.1~0.52 (15~75)	4.14 (600)	1/4" NPT (F)
GHPS-6E	0.35~3.1 (51~450)	13.79 (2000)	1/4" NPT (F)

Pressure Transmitter

Model Number	Parameter
5310-B-36CP	High Pressure: 0-3600 psi, Threaded Connection: 1/4-18NPT, Electrical Connection: Din9.4mm, Output: 4-20mA
5310-B-300P2	Low Pressure: 0-300 psi, Threaded Connection: 1/4-18NPT, Electrical Connection: Din9.4mm, Output: 4-20mA



MANIFOLD COMPONENTS

Gas Filter / Filter Elements / Gas Heater / Remote Alarm Panels

Industrial Manifold Systems

Gas Filter

The gas filter is used in high pressure pipeline system to effectively eliminate the dust in the gas. Its main body is made of high quality brass and its unique structure facilitates the replacement of the filter screen.



Model Number	Gas Service	Max. Inlet Pressure psi (bar)	Inlet Connection	Outlet Connection
GF40HP	All Gases (Except Oxygen)	3000 (207)	1"-11-1/2NPS RH (F)	1"-11-1/2NPS RH (M)
GF40HPO	Oxygen	3000 (207)	1"-11-1/2NPS RH (F)	1"-11-1/2NPS RH (M)

*All gases = non-corrosive gases

Filter Elements

Model Number	Gas Service	Description
CF30P-03A	Oxygen	Sintered Brass, Filtration precision: 100 µm
CF30P-03	All Gases (Except Oxygen)	Sintered Stainless Steel, Filtration precision: 30 µm



CF30P-03A

CF30P-03

Gas Heater

Machined with class "A" brass stock and used in high pressure pipeline system. Ideal for continuous heating of carbon dioxide and nitrous oxide to prevent gas from freezing the piping system.



H900G-200-D

Model Number	Working Pressure psi (bar)	Delivery Flow (SCFH)	Voltage	Power	Temperature	Inlet Connection	Outlet Connection
H900G-220-D	3000 (207)	1800	220 VAC	900 W	120 °F ~ 160 °F	1" -11-1/2 NPS RH (F)	1" -11-1/2 NPS RH (M)

Remote Alarm Panels

Remote alarm panel is suitable for all manifold systems. The alarm is activated to provide audio and visual warning when the service bank is empty. A press of reset button in front of the panel will silence the buzzer. The red alarm light will remain illuminated until the empty bank is replaced.

- Apparent audible & visual alarm indication
- With alarm silencing button
- Cable connector, safe and convenient
- Custom-ordered multiple alarms
- Can be installed on the gas source port according to the customer request

Model Number	Supply Voltage	Alarm Type	Signal Type	NO. of Gases
SGPA-1-220	110V, 220V	AUDIO & VISUAL ALARM	SWITCH SIGNAL	1
SGPA-2-220	110V, 220V	AUDIO & VISUAL ALARM	SWITCH SIGNAL	2
SGPA-4-220	110V, 220V	AUDIO & VISUAL ALARM	SWITCH SIGNAL	4



Gas Terminal Box

GSOB & GSOL Series Gas Terminals are designed for gas delivery workstations. GSOB (Box) and GSOL series (Line piping) consist of 3 types of gas outlets within a casing: direct, regulator, and flowmeter outlet. (Inlet Connection: 1/2" union).

Model Number	Gas Service	NO. of Outlet	Outlet Connection	Description
GSOB-3X	Oxygen	3	M16 X 1.5-RH (M)	Direct Type
GSOB-3Y	Alylene	3	M16 X 1.5-LH (M)	Direct Type, with Flashback Arrestor
GSOB-3F	Propane, LPG	3	M16 X 1.5-LH (M)	Direct Type, with Flashback Arrestor
GSOB-3C	Carbon Dioxide	3	M16 X 1.5-RH (M)	Direct Type
GSOB-3IN	Argon	3	M16 X 1.5-RH (M)	Direct Type
GSOB-3RX	Oxygen	3	M16 X 1.5-RH (M)	Regulator Type
GSOB-3RY	Alylene	3	M16 X 1.5-LH (M)	Regulator Type, with Flashback Arrestor
GSOB-3RF	Propane, LPG	3	M16 X 1.5-LH (M)	Regulator Type, with Flashback Arrestor
GSOB-2RX	Oxygen	2	M16 X 1.5-RH (M)	Regulator Type
GSOB-2RY	Alylene	2	M16 X 1.5-LH (M)	Regulator Type, with Flashback Arrestor
GSOB-2RF	Propane, LPG	2	M16 X 1.5-LH (M)	Regulator Type, with Flashback Arrestor
GSOB-1RX	Oxygen	1	M16 X 1.5-RH (M)	Regulator Type
GSOB-1RY	Alylene	1	M16 X 1.5-LH (M)	Regulator Type, with Flashback Arrestor
GSOB-1RF	Propane, LPG	1	M16 X 1.5-LH (M)	Regulator Type, with Flashback Arrestor
GSOB-3FC	Carbon Dioxide	3	M16 X 1.5-RH (M)	Flowmeter Type
GSOB-3FIN	Argon	3	M16 X 1.5-RH (M)	Flowmeter Type
GSOB-2FC	Carbon Dioxide	2	M16 X 1.5-RH (M)	Flowmeter Type
GSOB-2FIN	Argon	2	M16 X 1.5-RH (M)	Flowmeter Type
GSOB-1FC	Carbon Dioxide	1	M16 X 1.5-RH (M)	Flowmeter Type
GSOB-1FIN	Argon	1	M16 X 1.5-RH (M)	Flowmeter Type



GSOB-3FC (Box)



GSOB-3RF (Box)

Station Drops

Model Number	Gas Service	NO. of Outlet	Outlet Connection
GSOL-1X-R	Argon, Carbon Dioxide, Oxygen	1	G5/8"-14RH (M)
GSOL-2X-R	Argon, Carbon Dioxide, Oxygen	2	G5/8"-14RH (M)
GSOL-1X-H	Argon, Carbon Dioxide, Oxygen	1	M16 X 1.5-RH (M)
GSOL-1F-R	Acetylene, Propane	1	G5/8"-14RH (M)
GSOL-4F-R	Acetylene, Propane	4	G5/8"-14RH (M)
GSOL-2F-H	Acetylene, Propane	2	M16 X 1.5-LH (M)
GSOL-4F-H	Acetylene, Propane	4	M16 X 1.5-LH (M)



GSOL-2X-R (Line Piping)

Terminal Gas Control Panel

Model Number	Gas Service	Max. Inlet Pressure psi (bar)	Delivery Pressure psi (bar)	Inlet Connection	Outlet Connection
P1520F	Propane	400 (25)	0~40 (2.5)	BSP 1/4"	1/4" Hose Nipple
P1520X	Oxygen	400 (25)	0~125 (8.5)	BSP 1/4"	1/4" Hose Nipple
P1520Y	Acetylene	400 (25)	0~15 (1)	BSP 1/4"	1/4" Hose Nipple
P1520IN	Ar, He, N ₂	400 (25)	0~125 (8.5)	BSP 1/4"	1/4" Hose Nipple



P1520

Regulator Flashback Arrestors

Designed for mounting on the regulator outlet. Internal stainless steel sintered elements and check valves are constructed to provide protection from flashbacks.

Model Number	Gas Service	Working Pressure psi (bar)	Inlet Connection	Outlet Connection
FA9RF	Acetylene, Propane, LPG	22 (1.5)	9/16-18LH (F)	9/16-18LH (M)
FA9RO	Oxygen	145 (10)	9/16-18RH (F)	9/16-18RH (M)



FA9RF



FA9RO

Quick Connectors with Check Valve

Designed with a check valve to provide protection from flashbacks during gas cutting processes. The quick-opening valve at the end of the connector facilitates the connections.

Model Number	Gas Service	Working Pressure psi (bar)	Inlet Connection	Outlet Connection
RH36X	Oxygen	145 (10)	9/16-18RH (F)	9/16-18RH (F)
RH36F	Fuel Gas	30 (2)	9/16-18LH (F)	9/16-18LH (F)
RH39X	Oxygen	145 (10)	9/16-18RH (F)	5/16" Hose Nipple
RH39F	Fuel Gas	30 (2)	9/16-18LH (F)	5/16" Nipple



RH39F



RH39X

Flowmeters (Suitable for use on Piping Systems)

Series	Model Number	Gas Service	Delivery Flow (SCFH)	Max. Inlet Pressure psi (bar)	Inlet Connection	Outlet Connection
191FM SERIES	191FM-25L	Carbon Dioxide	0-55	50 (3.5)	1/4" NPT (M)	9/16-18RH (M)
	191FM-25L	Argon	0-55	50 (3.5)	1/4" NPT (M)	9/16-18RH (M)
	191FM-25L	Helium	0-170	50 (3.5)	1/4" NPT (M)	9/16-18RH (M)
	191FM-50L	Carbon Dioxide	0-105	50 (3.5)	1/4" NPT (M)	9/16-18RH (M)
	191FM-50L	Argon	0-105	50 (3.5)	1/4" NPT (M)	9/16-18RH (M)
	191FM-50L	Helium	0-240	50 (3.5)	1/4" NPT (M)	9/16-18RH (M)
	191FM-30L	Nitrogen	0-65	50 (3.5)	1/4" NPT (M)	9/16-18RH (M)
	191FM-30L	Air	0-65	50 (3.5)	1/4" NPT (M)	9/16-18RH (M)
	191FM-100L	Hydrogen	0-210	50 (3.5)	1/4" NPT (M)	9/16-18LH (M)
191FM-F SERIES	191FM-25L-F	Carbon Dioxide	0-55	50 (3.5)	9/16-18RH (F)	9/16-18RH (M)
	191FM-25L-F	Argon	0-55	50 (3.5)	9/16-18RH (F)	9/16-18RH (M)
	191FM-25L-F	Helium	0-170	50 (3.5)	9/16-18RH (F)	9/16-18RH (M)
	191FM-50L-F	Carbon Dioxide	0-105	50 (3.5)	9/16-18RH (F)	9/16-18RH (M)
	191FM-50L-F	Argon	0-105	50 (3.5)	9/16-18RH (F)	9/16-18RH (M)
	191FM-50L-F	Helium	0-340	50 (3.5)	9/16-18RH (F)	9/16-18RH (M)
	191FM-30L-F	Nitrogen	0-65	50 (3.5)	9/16-18RH (F)	9/16-18RH (M)
	191FM-30L-F	Air	0-65	50 (3.5)	9/16-18RH (F)	9/16-18RH (M)
	191FM-100L-F	Hydrogen	0-210	50 (3.5)	9/16-18RH (F)	9/16-18LH (M)



191FM-25L



191FM-25L-F

155CG, 155M, 155TM, 153M Series



155CG



155M



155TM



153M

Patent No. 200520014547.8

Series	Model Number	Gas Service	Delivery Flow (SCFH)	Max. Inlet Pressure (psi (bar))	Inlet Connection	Outlet Connection
155CG series electric heating	155CG-125-220	CO ₂	2200 (150)	4.4~120 (0.3~8.5)	1"-11-1/2"NPS RH (M)	1"-11-1/2"NPS RH (F)
	155CG-200-220		2200 (150)	10~200 (0.7~14)	1"-11-1/2"NPS RH (M)	1"-11-1/2"NPS RH (F)
155M-A series (ultra high flow system) single-stage	155MX-125-A	O ₂	2200 (150)	4.4~120 (0.3~8.5)	1"-11-1/2"NPS RH (M)	1"-11-1/2"NPS RH (F)
	155MX-200-A		2200 (150)	10~200 (0.7~14)	1"-11-1/2"NPS RH (M)	1"-11-1/2"NPS RH (F)
	155MY-15-A	C ₂ H ₂	435 (30)	1.5~14.5 (0.1~1)	1"-11-1/2"NPS LH (M)	1"-11-1/2"NPS LH (F)
	155MF-40-A	C ₃ H ₈ , LPG	435 (30)	1.5~40 (0.1~2.8)	1"-11-1/2"NPS LH (M)	1"-11-1/2"NPS LH (F)
	155MIN-125-A	Ar, He, N ₂	2200 (150)	4.4~120 (0.3~8.5)	1"-11-1/2"NPS RH (M)	1"-11-1/2"NPS RH (F)
	155MIN-200-A		2200 (150)	10~200 (0.7~14)	1"-11-1/2"NPS RH (M)	1"-11-1/2"NPS RH (F)
	155MQ-125-A	Air	2200 (150)	4.4~120 (0.3~8.5)	1"-11-1/2"NPS RH (M)	1"-11-1/2"NPS RH (F)
	155MQ-200-A		2200 (150)	10~200 (0.7~14)	1"-11-1/2"NPS RH (M)	1"-11-1/2"NPS RH (F)
	155MH-200-A	H ₂	2200 (150)	10~200 (0.7~14)	1"-11-1/2"NPS LH (M)	1"-11-1/2"NPS LH (F)
	155MC-125-A	CO ₂	2200 (150)	4.4~120 (0.3~8.5)	1"-11-1/2"NPS RH (M)	1"-11-1/2"NPS RH (F)
155MC-200-A	2200 (150)		10~200 (0.7~14)	1"-11-1/2"NPS RH (M)	1"-11-1/2"NPS RH (F)	
155TM-A series (ultra high flow system) dual-stage	155TMX-125-A	O ₂	2200 (150)	4.4~120 (0.3~8.5)	1"-11-1/2"NPS RH (M)	1"-11-1/2"NPS RH (F)
	155TMX-200-A		2200 (150)	10~200 (0.7~14)	1"-11-1/2"NPS RH (M)	1"-11-1/2"NPS RH (F)
	155TMY-15-A	C ₂ H ₂	435 (30)	1.5~14.5 (0.1~1)	1"-11-1/2"NPS LH (M)	1"-11-1/2"NPS LH (F)
	155TMF-40-A	C ₃ H ₈ , LPG	435 (30)	1.5~40 (0.1~2.8)	1"-11-1/2"NPS LH (M)	1"-11-1/2"NPS LH (F)
	155TMIN-125-A	Ar, He, N ₂	2200 (150)	4.4~120 (0.3~8.5)	1"-11-1/2"NPS RH (M)	1"-11-1/2"NPS RH (F)
	155TMIN-200-A		2200 (150)	10~200 (0.7~14)	1"-11-1/2"NPS RH (M)	1"-11-1/2"NPS RH (F)
	155TMC-125-A	CO ₂	2200 (150)	4.4~120 (0.3~8.5)	1"-11-1/2"NPS RH (M)	1"-11-1/2"NPS RH (F)
155TMC-200-A	2200 (150)		10~200 (0.7~14)	1"-11-1/2"NPS RH (M)	1"-11-1/2"NPS RH (F)	
153M-A series (ultra high flow system) single-stage	153MX-125-A	O ₂	2200 (150)	4.4~120 (0.3~8.5)	1"-11-1/2"NPS RH (M)	1"-11-1/2"NPS RH (F)
	153MX-200-A		2200 (150)	10~200 (0.7~14)	1"-11-1/2"NPS RH (M)	1"-11-1/2"NPS RH (F)
	153MY-15-A	C ₂ H ₂	435 (30)	1.5~14.5 (0.1~1)	1"-11-1/2"NPS LH (M)	1"-11-1/2"NPS LH (F)
	153MF-40-A	C ₃ H ₈ , LPG	435 (30)	1.5~40 (0.1~2.8)	1"-11-1/2"NPS LH (M)	1"-11-1/2"NPS LH (F)
	153MF-125-A	LPG	435 (30)	4.4~120 (0.3~8.5)	1"-11-1/2"NPS LH (M)	1"-11-1/2"NPS LH (F)
	153MIN-125-A	Ar, He, N ₂	2200 (150)	4.4~120 (0.3~8.5)	1"-11-1/2"NPS LH (M)	1"-11-1/2"NPS LH (F)
	153MIN-200-A		2200 (150)	10~200 (0.7~14)	1"-11-1/2"NPS RH (M)	1"-11-1/2"NPS RH (F)
	153MQ-125-A	Air	2200 (150)	4.4~120 (0.3~8.5)	1"-11-1/2"NPS RH (M)	1"-11-1/2"NPS RH (F)
	153MQ-200-A		2200 (150)	10~200 (0.7~14)	1"-11-1/2"NPS RH (M)	1"-11-1/2"NPS RH (F)
	153MH-15-A	H ₂	2200 (150)	1.5~14.5 (0.1~1)	1"-11-1/2"NPS LH (M)	1"-11-1/2"NPS LH (F)
	153MH-200-A		2200 (150)	10~200 (0.7~14)	1"-11-1/2"NPS LH (M)	1"-11-1/2"NPS LH (F)
	153MC-125-A	CO ₂	2200 (150)	4.4~120 (0.3~8.5)	1"-11-1/2"NPS LH (M)	1"-11-1/2"NPS LH (F)
	153MC-200-A		2200 (150)	10~200 (0.7~14)	1"-11-1/2"NPS RH (M)	1"-11-1/2"NPS RH (F)

MANIFOLD COMPONENTS

Manifold Regulators

Industrial Manifold Systems

591, LC853, 155HF Series



591



155HF

Series	Model Number	Gas Service	Delivery Flow (SCFH)	Max. Inlet Pressure (psi (bar))	Inlet Connection	Outlet Connection
591 series (suitable for high outlet pressure)	591X-750	O ₂	2900 (200)	4.4~125 (0.3~8.5)	G5/8"-RH (F)	Φ6
	591X-1500		2900 (200)	102~145 (7~10)	G5/8"-RH (F)	Φ6
	591X-3000		2900 (200)	200~2900 (14~200)	G5/8"-RH (F)	Φ6
	591X-3000-577		3600 (250)	200~2900 (14~200)	CGA577	Φ6
	591X-4500-701	Ar, He, N ₂	3600 (250)	300~4350 (21~300)	CGA701	Φ6
	591IN-1500		2900 (200)	100~145 (7~10)	G5/8"-RH (F)	Φ6
	591IN-3000		3600 (250)	200~2900 (14~200)	G5/8"-RH (F)	Φ6
	591IN-4500-667		5100 (350)	300~4350 (21~300)	CGA667	Φ6
	591Q-1500		Air	2900 (200)	100~145 (7~10)	G5/8"-RH (F)
	591Q-3000	2900 (200)		200~2900 (14~200)	G5/8"-RH (F)	Φ6
	591Q-4500-680	5100 (350)		300~4350 (21~300)	CGA680	Φ6
	591H-750	H ₂	2900 (200)	50~725 (3.5~50)	W21.8-14LH	Φ6
			591H-1500	2900 (200)	100~145 (7~10)	W21.8-14LH
591H-3000			2900 (200)	200~2900 (14~200)	W21.8-14LH	Φ6
LC853 series (suitable for liquid vessels)	LC853X-125	O ₂	500 (35)	4.4~120 (0.3~8.5)	G3/4"-RH (F)	G3/4"-RH (F)
	LC853C-125	CO ₂	500 (35)	4.4~120 (0.3~8.5)	G3/4"-RH (F)	G3/4"-RH (F)
	LC853IN-125	Ar, N ₂	500 (35)	4.4~120 (0.3~8.5)	G3/4"-RH (F)	G3/4"-RH (F)
155HF series (suitable for high pressure and flow)	155HFX-800	O ₂	2200 (150)	50~800 (3.5~55)	G5/8"-RH (F)	M22-1.5RH (M)
	155HFIN-800	Ar, He, N ₂	2200 (150)	50~800 (3.5~55)	G5/8"-RH (F)	M22-1.5RH (M)

R66B Series

- Suitable for low pressure and high flow

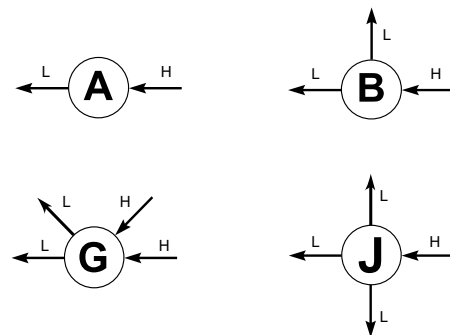

R66B	J	B	- D	Q	G	- 00	- 00
Series	Body Ports	Seat	Inlet Pressure	Outlet Pressure	Pressure Gauge	Inlet Connection	Outlet Connection
R66B (Brass)	A B G J	B: Nitrile Rubber	F: 0~500 psi	G: 0~250 psi H: 0~1250 psi I: 0~100 psi K: 0~50 psi L: 0~25 psi	W: Without pressure gauge P: with psi/bar gauge G: with Mpa gauge	06: 3/4" NPT (F) 08: 1" NPT (F) Other types of connectors are available.	06: 3/4" NPT (F) 08: 1" NPT (F) Other types of connectors are available.

155L, 152L, 853L, 210SR, 152S, 853SR Series

- Station & Line regulators should not be used with cylinders.
- 152L, 155L, 853L series regulators can adopt M16*1.5 inlet and outlet thread connections.



*: Adjusting T-bar can be replaced by adjusting knob for all regulators listed above.

Series	Model Number	Gas Service	Mx. Inlet Pressure psi (bar)	Delivery Pressure psi (bar)	Inlet Connection	Outlet Connection
155L series (high flow gas distribution system)	155LX-80	O ₂	360 (25)	2.9~80 (0.2~5.6)	3/4" NPT (F)	3/4" NPT (F)
	155LX-125		360 (25)	4.4~120 (0.3~8.5)	3/4" NPT (F)	3/4" NPT (F)
	155LX-200		360 (25)	10~200 (0.7~14)	3/4" NPT (F)	3/4" NPT (F)
	155LY-15	C ₂ H ₂	360 (25)	1.5~14.5 (0.1~1)	3/4" NPT (F)	3/4" NPT (F)
	155LF-125	C ₃ H ₈ , LPG	360 (25)	4.4~120 (0.3~8.5)	3/4" NPT (F)	3/4" NPT (F)
	155LIN-80	Ar, He, N ₂	360 (25)	2.9~80 (0.2~5.6)	3/4" NPT (F)	3/4" NPT (F)
	155LIN-125		360 (25)	4.4~120 (0.3~8.5)	3/4" NPT (F)	3/4" NPT (F)
	155LIN-200		360 (25)	10~200 (0.7~14)	3/4" NPT (F)	3/4" NPT (F)
	155LQ-80	Air	360 (25)	2.9~80 (0.2~5.6)	3/4" NPT (F)	3/4" NPT (F)
	155LQ-125		360 (25)	4.4~120 (0.3~8.5)	3/4" NPT (F)	3/4" NPT (F)
	155LQ-200		360 (25)	10~200 (0.7~14)	3/4" NPT (F)	3/4" NPT (F)
	155LH-125	H ₂	360 (25)	4.4~120 (0.3~8.5)	3/4" NPT (F)	3/4" NPT (F)
155LC-125	CO ₂	360 (25)	4.4~120 (0.3~8.5)	3/4" NPT (F)	3/4" NPT (F)	
152L series (low flow gas distribution system)	152LX-125	O ₂	360 (25)	4.4~120 (0.3~8.5)	1/4" NPT (F)	1/4" NPT (F)
	152LY-15	C ₂ H ₂	360 (25)	1.5~14.5 (0.1~1)	1/4" NPT (F)	1/4" NPT (F)
	152LF-80	C ₃ H ₈ , LPG	360 (25)	2.9~80 (0.2~5.6)	1/4" NPT (F)	1/4" NPT (F)
	152LIN-125	Ar, He, N ₂	360 (25)	4.4~120 (0.3~8.5)	1/4" NPT (F)	1/4" NPT (F)
	152LQ-125	Air	360 (25)	4.4~120 (0.3~8.5)	1/4" NPT (F)	1/4" NPT (F)
	152LH-80	H ₂	360 (25)	2.9~80 (0.2~5.6)	1/4" NPT (F)	1/4" NPT (F)
	152LC-125	CO ₂	360 (25)	4.4~120 (0.3~8.5)	1/4" NPT (F)	1/4" NPT (F)
853L series (Moderate flow gas distribution system)	853LX-125	O ₂	360 (25)	4.4~120 (0.3~8.5)	1/4" NPT (F)	1/4" NPT (F)
	853LY-15	C ₂ H ₂	360 (25)	1.5~14.5 (0.1~1)	1/4" NPT (F)	1/4" NPT (F)
	853LF-80	C ₃ H ₈ , LPG	360 (25)	2.9~80 (0.2~5.6)	1/4" NPT (F)	1/4" NPT (F)
	853LF-125		360 (25)	4.4~120 (0.3~8.5)	1/4" NPT (F)	1/4" NPT (F)
	853LIN-125	Ar, He, N ₂	360 (25)	4.4~120 (0.3~8.5)	1/4" NPT (F)	1/4" NPT (F)
	853LQ-125	Air	360 (25)	4.4~120 (0.3~8.5)	1/4" NPT (F)	1/4" NPT (F)
	853LH-80	H ₂	360 (25)	2.9~80 (0.2~5.6)	1/4" NPT (F)	1/4" NPT (F)
	853LH-125		360 (25)	4.4~120 (0.3~8.5)	1/4" NPT (F)	1/4" NPT (F)
853LC-125	CO ₂	360 (25)	4.4~120 (0.3~8.5)	1/4" NPT (F)	1/4" NPT (F)	

MANIFOLD COMPONENTS

Station & Line Regulators

Industrial Manifold Systems

Series	Model Number	Gas Service	Max. Inlet Pressure psi (bar)	Delivery Pressure psi (bar)	Inlet Connection	Outlet Connection
210SR series (low flow gas distribution system) Rear input structure	210SRX-80	O ₂	200 (14)	2.9~80 (0.2~5.6)	M16-1.5RH (F)	M16-1.5RH (M)
	210SRX-125		200 (14)	4.4~120 (0.3~8.5)	M16-1.5RH (F)	M16-1.5RH (M)
	210SRY-15	C ₂ H ₂	200 (14)	1.5~14.5 (0.1~1)	M16-1.5LH (F)	M16-1.5LH (M)
	210SRF-15	C ₃ H ₈ , LPG	200 (14)	1.5~14.5 (0.1~1)	M16-1.5LH (F)	M16-1.5LH (M)
	210SRIN-80	Ar, He, N ₂	200 (14)	2.9~80 (0.2~5.6)	M16-1.5RH (F)	M16-1.5RH (M)
	210SRIN-125		200 (14)	4.4~120 (0.3~8.5)	M16-1.5RH (F)	M16-1.5RH (M)
	210SRQ-80	Air	200 (14)	2.9~80 (0.2~5.6)	M16-1.5RH (F)	M16-1.5RH (M)
	210SRQ-125		200 (14)	4.4~120 (0.3~8.5)	M16-1.5RH (F)	M16-1.5RH (M)
	210SRH-80	H ₂	200 (14)	2.9~80 (0.2~5.6)	M16-1.5LH (F)	M16-1.5LH (M)
	210SRH-125		200 (14)	4.4~120 (0.3~8.5)	M16-1.5LH (F)	M16-1.5LH (M)
	210SRC-125	CO ₂	200 (14)	4.4~120 (0.3~8.5)	M16-1.5RH (F)	M16-1.5RH (M)
152S series (Moderate and high flow gas distribution system)	152SX-40	O ₂	200 (14)	1.5~14.5 (0.1~1)	G5/8"-RH (F)	M16-1.5RH (M)
	152SX-80		200 (14)	2.9~80 (0.2~5.6)	G5/8"-RH (F)	M16-1.5RH (M)
	152SX-125		200 (14)	4.4~120 (0.3~8.5)	G5/8"-RH (F)	M16-1.5RH (M)
	152SY-15	C ₂ H ₂	200 (14)	1.5~14.5 (0.1~1)	G5/8"-LH (F)	M16-1.5LH (M)
	152SF-80	C ₃ H ₈ , LPG	200 (14)	2.9~80 (0.2~5.6)	G5/8"-LH (F)	M16-1.5LH (M)
	152SF-125		200 (14)	4.4~120 (0.3~8.5)	G5/8"-LH (F)	M16-1.5LH (M)
	152SIN-40	Ar, He, N ₂	200 (14)	1.5~14.5 (0.1~1)	G5/8"-RH (F)	M16-1.5RH (M)
	152SIN-80		200 (14)	2.9~80 (0.2~5.6)	G5/8"-RH (F)	M16-1.5RH (M)
	152SIN-125		200 (14)	4.4~120 (0.3~8.5)	G5/8"-RH (F)	M16-1.5RH (M)
	152SQ-40	Air	200 (14)	1.5~14.5 (0.1~1)	G5/8"-RH (F)	M16-1.5RH (M)
	152SH-80	H ₂	200 (14)	2.9~80 (0.2~5.6)	G5/8"-LH (F)	M16-1.5LH (M)
	152SH-125		200 (14)	4.4~120 (0.3~8.5)	G5/8"-LH (F)	M16-1.5LH (M)
	152SC-40	CO ₂	200 (14)	1.5~14.5 (0.1~1)	G5/8"-RH (F)	M16-1.5RH (M)
	152SC-80		200 (14)	2.9~80 (0.2~5.6)	G5/8"-RH (F)	M16-1.5RH (M)
	152SC-125		200 (14)	4.4~120 (0.3~8.5)	G5/8"-RH (F)	M16-1.5RH (M)
853SR series (high flow gas distribution system) Rear input structure	853SRX-80	O ₂	200 (14)	2.9~80 (0.2~5.6)	G5/8"-RH (F)	M16-1.5RH (M)
	853SRX-125		200 (14)	4.4~120 (0.3~8.5)	G5/8"-RH (F)	M16-1.5RH (M)
	853SRY-15	C ₂ H ₂	200 (14)	1.5~14.5 (0.1~1)	G5/8"-LH (F)	M16-1.5LH (M)
	853SRF-80	C ₃ H ₈ , LPG	200 (14)	2.9~80 (0.2~5.6)	G5/8"-LH (F)	M16-1.5LH (M)
	853SRF-125		200 (14)	4.4~120 (0.3~8.5)	G5/8"-LH (F)	M16-1.5LH (M)
	853SRIN-40	Ar, He, N ₂	200 (14)	1.5~14.5 (0.1~1)	G5/8"-RH (F)	M16-1.5RH (M)
	853SRIN-80		200 (14)	2.9~80 (0.2~5.6)	G5/8"-RH (F)	M16-1.5RH (M)
	853SRIN-125		200 (14)	4.4~120 (0.3~8.5)	G5/8"-RH (F)	M16-1.5RH (M)
	853SRQ-40	Air	200 (14)	1.5~14.5 (0.1~1)	G5/8"-RH (F)	M16-1.5RH (M)
	853SRQ-80		200 (14)	2.9~80 (0.2~5.6)	G5/8"-RH (F)	M16-1.5RH (M)
	853SRQ-125		200 (14)	4.4~120 (0.3~8.5)	G5/8"-RH (F)	M16-1.5RH (M)
	853SRH-80	H ₂	200 (14)	2.9~80 (0.2~5.6)	G5/8"-LH (F)	M16-1.5LH (M)
	853SRH-125		200 (14)	4.4~120 (0.3~8.5)	G5/8"-LH (F)	M16-1.5LH (M)
	853SRC-40	CO ₂	200 (14)	1.5~14.5 (0.1~1)	G5/8"-RH (F)	M16-1.5RH (M)
	853SRC-80		200 (14)	2.9~80 (0.2~5.6)	G5/8"-RH (F)	M16-1.5RH (M)
	853SRC-125		200 (14)	4.4~120 (0.3~8.5)	G5/8"-RH (F)	M16-1.5RH (M)

Any GENTEC® apparatus found to be defective either in material or workmanship during the time set forth below will be replaced by Genstar Technologies Company, Incorporated or its Authorized Distributors, provided that said apparatus was used under normal conditions for the purpose intended.

Limited Warranty Period: The warranty period is as shown below, from the date of original purchase.

Product Type	Warranty from the Date of Original Purchase
Gas Manifold Systems	2 years
Pigtails	90 days

GENTEC® apparatus damaged or rendered inoperative due to abuse, negligence, misuse, accident or abnormal wear and tear is not covered by this warranty and must be repaired at the sole expense of the equipment owner. GENTEC® apparatus should be serviced or repaired by Genstar Technologies Company, Incorporated or designated service facilities only. Service or repair of this apparatus by other than Genstar Technologies Company, Incorporated or designated service facilities may void any warranties and relieve Genstar Technologies Company, Incorporated of any claims for damage and/or liability.

To make a claim under this warranty, Buyer must notify Genstar Technologies Company, Incorporated or its Authorized Distributor of the details of such claim within 30 days of discovering a defect in material or workmanship along with proof of purchase. The Buyer will be responsible for transportation costs and related risks.

Genstar Technologies Company, Incorporated shall not, under any circumstances, be liable for any damages including but not limited to: indirect, incidental, consequential, or special damages, whether such damages result from negligence, breach of warranty or otherwise.

There are no other warranties, expressed or implied, except as stated herein. This warranty gives you specific legal rights, and you may also have other rights which vary from state to state. Genstar Technologies Company, Incorporated reserves the right to discontinue manufacturing of any product or change product materials, design or specifications without notice.

CRYOGENIC VESSEL

What you need to know?

- Vaporization Rate: Typically 250 to 350 SCFH.
- Outlet Pressure: Typically 125 psi, 300 psi Models are also available.
- Evaporization Rate: Up to 3% per day will vent to atmosphere.
- Temperature: Vaporizing gas is very cold. Approximately -300O Fahrenheit.

Warning: Multiple liquid cylinder manifolds MUST have the pressure building regulator of each vessel set at the same pressure to insure proper cylinder withdrawal.

HOW MANY CYLINDERS DO I NEED?

Example of argon mix manifold system at a mig welding shop:

- For a 250 CF cylinder, automatic changeover uses 230 CF and leaves 20CF in the cylinder.

Manual changeover uses 250CF.

$(28 \text{ CFH/Station}) \times 6.5 \text{ Hours/Day} \times 50\% \text{ Duty Cycle} = 91.0 \text{ CF/Day/Station}$

- $91.0 \text{ CF/Day/Station} \times 8 \text{ Welding Stations} = 728 \text{ CF/Day}$

$$\frac{728 \text{ CF/Day}}{230 \text{ CF/Cylinder}} = 3.16 \text{ Cylinders/Day}$$

$$\frac{12 \text{ Cylinders per Header}}{3.16 \text{ Cylinders/Day}} = 3.8 \text{ Days per Header} \times 2 \text{ Headers} = \text{Maximum 7.6 Days between deliveries}$$

- Minimum Gas supply of 1 day required. Thus, in order to get gas delivered once a week (ie. every Wednesday) there will be 24 cylinders delivered every seven days in order to have uninterrupted service with an automatic manifold.



Gas Welding & Cutting Apparatus

- Gold Series Deluxe Outfits
- Cutting Outfits
- Torch Handles
- Cutting Attachments
- Hand Cutting Torches
- Machine Cutting Torches & Accessories
- Check Valves, Quick Connectors,
- Flashback Arrestors
- Welding , Heating Nozzles, Cutting Tips
- The Small Torch, The Compact Torch
- MUL-T-TORCH Outfit & Components
- Compressed Gas Regulators



Medical Gas Systems & Devices Overview

- Medical Gas Systems Total Solution
- Source Equipment
- Zone Valve Box & Area Valve Service Unit
- Monitoring Alarm & Control System
- Art Wall Enclosure
- Medical Console Units
- Medical Gas Outlets
- Anaesthetic Gas Scavenging System
- Oxygen Therapy
- Suction Therapy
- Oxygen Concentrator & Nebulizers
- Respiratory Care

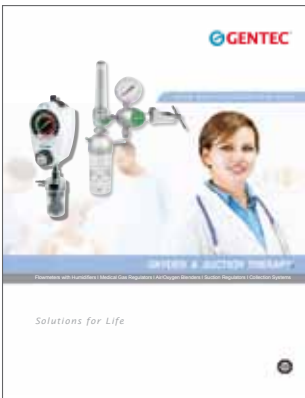

Oxygen & Suction Therapy

- Oxygen Therapy
- Suction Therapy



Specialty Gas Equipment

- General Purpose Forged Brass Regulators
- High Purity Brass Barstock Regulators
- High Purity Stainless Steel Barstock Regulators
- Ultra High Purity Regulators
- Header Manifolds
- Switchover Manifolds
- Manual Bank Manifolds
- Gas Panels
- Gas Safety Cabinets
- Generators
- Accessories



Genstar Technologies Company, Inc.
4525 Edison Avenue, Chino, CA 91710, USA
Tel: 909-606-2726
Fax: 909-606-6485
www.gentec.com

