



## CRYOGENIC GAS EQUIPMENT



## Company Overview

Genstar Technologies is a global leader in Gas Flow Control Systems for the industrial, specialty gas and medical sectors. We pride ourselves in our ability to provide our customers with high quality, value-added products and services that go beyond the industry standards. As a result, we have a global network of thousands of satisfied customers in over 60 countries.

## Our Team

Our highly educated team of engineers, salespeople, technicians, managers, and customer service personnel are dedicated to providing you with products with the highest quality, reliability and performance. We hold the highest standards to our manufacturing processes; our total process management maximizes our production efficiency while ensuring product quality.

We work closely with all of our customers to design products specific to your needs. This includes developing new products, redesigning existing products, and customizing configuration / packaging. It is our priority to foster a strong relationship with each and every customer.

## Quality Assurance

All of our products are manufactured under stringent quality control. We are ISO 9001:2001, ISO13485, and API certified. Our products meet UL, CE, SEMI, and various international standards and certifications.

## Manufacturing Capabilities

The manufacturing facility is equipped with CNC machines, electro-polishing equipment, and precision automated orbital welding systems, among other features, to ensure the production of the highest quality products.

## Clean Room Facilities

Our class 10/100/1000 clean rooms are designed for Ultra High Purity (UHP) products. UHP products undergo precision machining, surface finishing, electro-polishing and passivation. All UHP products are cleaned by 18M $\Omega$  DI water in a cascade ultrasonic tank. To ensure the highest UHP product quality, they are then vacuum-dried and double-bagged.



**3. RV95 Series**  
**Cryogenic Relief Valves**



**10. LCV01 Series Check Valves**  
**LCV05 Series Check Valves**



**4. V902 Series**  
**Cryogenic Shut-Off Valves**



**11. CRT-R10 Series**  
**LNG Nozzle/Quick Disconnect**



**5. LC851, LCE851, LCC851 Series**  
**Cryogenic Regulators**



**11. CRT-R200 Series**  
**LNG Receptacle**



**7. 255L Series**  
**Heavy Duty Gas Line Regulators**



**12. EV41, EV45 Series**  
**Excess Flow Valves**



**8. 853LCR Series**  
**Liquid Cylinder Regulators**



**13. Pressure Gauges**



**9. LC856 Series**  
**Heavy Duty Gas Line Regulators**

## GENTEC® Cryogenic Series

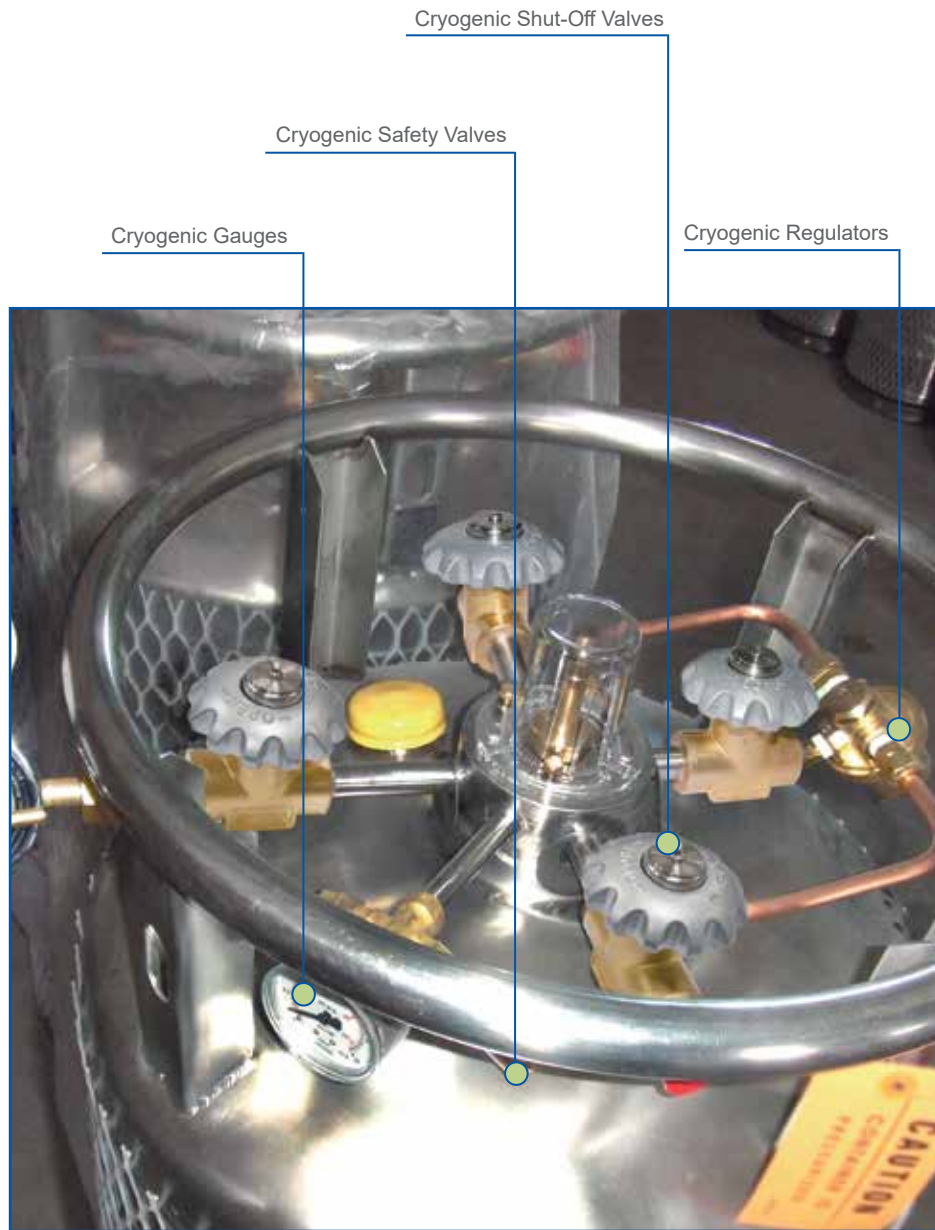

Cryogenic Gauges

Cryogenic Safety Valves

Cryogenic Shut-Off Valves

Cryogenic Regulators

CYLINDER DEWAR



## RV95 Series Cryogenic Relief Valves

This safety valve is specifically designed for cryogenic gases, and can be used for pipeline systems, cryogenic cylinders, or small cryogenic tanks. When the pressure in the system surpasses the preset pressure value, the valve will automatically start relieving excess pressure.

### Features

- Valve opens on preset value and reseats below 95%
- Operating Temperature
  - Fluorosilicone: 14 ~ 176°F (-10 ~ 80°C)
  - PTFE: -320 ~ 176°F (-196 ~ 80°C)
- Available Set Pressure: 22 ~ 500 psi (1.5 ~ 34.5 bar)
- Conforms to CGA G-4.1 for cleaning components
- Constructed with oxygen compatible materials

### Materials

- Valve Body: Brass, Stainless Steel
- Spring: Stainless Steel
- Pressure adjusting screw: Brass, Stainless Steel
- Seal: Fluorosilicone (Apply pressure: 22 ~ 100 psi)
  - PTFE (Apply pressure: 150 ~ 500 psi)



B-RV95



SS-RV95

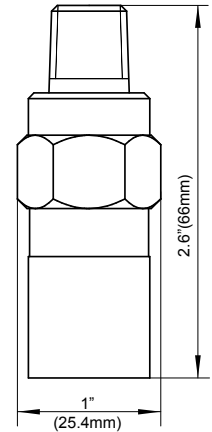

B-NUT3/4-FNT6



SS-NUT3/4-FNT6

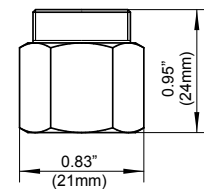

### Ordering Information

#### LNG The storage tank (without lateral holes)

Part Number	Model Number	Set Pressure	Inlet Connection
100055066	B-RV95-T120-NT4	120 psi	1/4"NPT
100055010	B-RV95-T150-NT4	150 psi	1/4"NPT
100055067	B-RV95-T230-NT4	230 psi	1/4"NPT
100055065	B-RV95-T250-NT4	250 psi	1/4"NPT
100055068	B-RV95-T300-NT4	300 psi	1/4"NPT
100055064	B-RV95-T350-NT4	350 psi	1/4"NPT

#### Dewar bottle (with side hole)

SS -	RV95 -	T	150 -	NT4
Body Material	Series	Seat Material	Set Pressure psi (bar)	Inlet Connection
SS: Stainless Steel B: Brass	RV95	F: Fluorosilicone (Set Pressure: 22, 35, 50, 100 psi) T: PTFE (Set Pressure: 150, 230, 350, 450, 500 psi)	22(1.5), 35(2.4), 50(3.5), 100(6.9), 150(10.3), 230(15.9), 350(24), 450(31), 500(35)	NT4: 1/4"NPT NT6: 3/8"NPT NT8: 1/2"NPT



# V902 SERIES

Cryogenic Shut-Off Valves

Solutions for Life

## V902 Series Cryogenic Shut-Off Valves

For effective use on cryogenic liquid cylinders or piping systems that may require an in line Shut-Off valve.



### Features

- Compact, easy to install
- Dampproof, dustproof cover design, to prevent low temperature freezing
- Conical spiral seal, to prevent excessive wear of valve seat torsion
- Max. Working Pressure: 600 psi (41.4 bar)
- Working Temperature: -320~165°F (-196~74 °C)
- Conforms to CGA E-4 Standard for Gas Pressure Regulators
- Cleaned for oxygen service per CGA 4.1

### Materials

- Body: Brass
- Inlet Tube: Brass and Stainless Steel
- External Seal: PTFE
- Inner : PCTFE
- Handwheel: Cast Aluminum 102
- Spring: Stainless Steel

### Dimensions

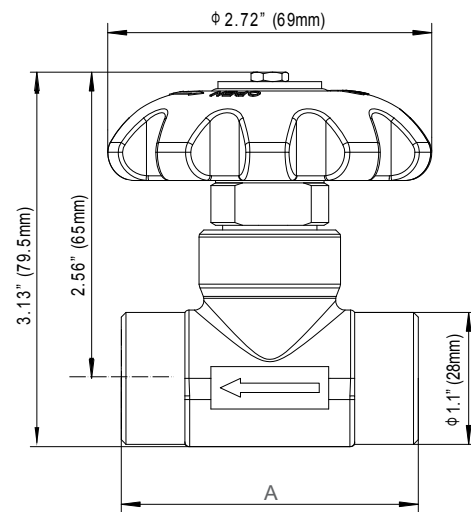

### Ordering Information

Model Number	Inlet Connection	Outlet Connection	Diameter in. (mm)	Inlet Tube Length in. (mm)	A Dimensions in. (mm)	Max. Cv
V902	3/8" NPT (F)	3/8" NPT (F)	0.393 (10)	/	2.48 (63)	0.98
V902A	ø16x1.5 mm	3/8" NPT (F)	0.393 (10)	1-1/8 (28.5)	3.46 (88)	0.98
V902B	ø16x1.5 mm	3/8" NPT (F)	0.393 (10)	2-1/8 (54.0)	4.45 (113)	0.98
V902C	ø16x1.5 mm	3/8" NPT (F)	0.393 (10)	3-1/8 (79.5)	5.47 (139)	0.98

## LC851, LCE851, LCC851 Series Cryogenic Regulators

The LC Series Regulator is available in three functions: Pressure Build, Economizer, and the Combination Pressure Build/Economizer. All regulators are cleaned for oxygen use per CGA 4.1.

### LC851 Series Pressure Build Regulators

Effective maintenance of pressure within the cylinder tank

- Bonnet and Body: Brass
- Seat: PTFE
- Spring: Stainless Steel
- Diaphragm: PTFE, Phosphor Bronze
- Max. Inlet Pressure: 550 psi (38 bar)
- Working Temperature: -320~165 °F (-196~74 °C)
- Conforms to CGA E-4 Standard for Gas Pressure Regulators
- Cleaned for oxygen service per CGA 4.1

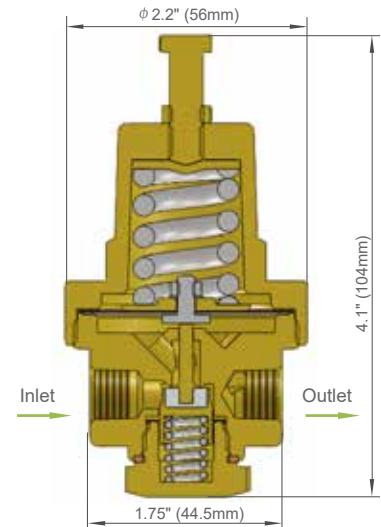

### Ordering Information

Model Number	Maximum Inlet Pressure psi (bar)	Operating Temperature °F(°C)	Inlet / Outlet Connection	Set Pressure psi (bar)	Pressure Range psi (bar)
LC851-125	550 (38)	-320~165 (-196~74)	1/4 NPT(F)	125 (8.5)	25~250 (1.7~17)
LC851-300	550 (38)	-320~165 (-196~74)	1/4 NPT(F)	300 (21)	125~350 (8.5~24)

### LCE851 Series Economizer Regulator

Improves efficiency and avoids wasting of gas

- Bonnet and Body: Brass
- Seat: PTFE
- Spring: stainless steel
- Diaphragm: PTFE, Phosphor bronze
- Max. Inlet Pressure: 550 psi (38 bar)
- Working Temperature: -320~165 °F (-196~74 °C)
- Conforms to CGA E-4 Standard for Gas Pressure Regulators
- Cleaned for oxygen service per CGA 4.1

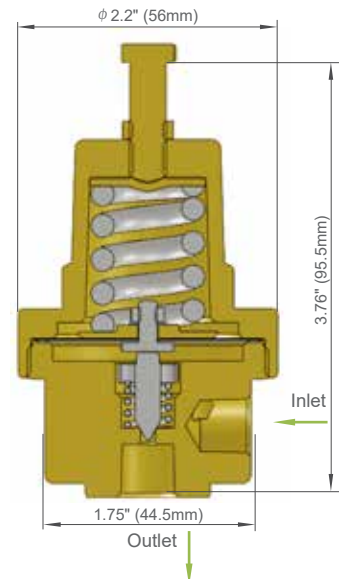

### Ordering Information

Model Number	Maximum Inlet Pressure psi (bar)	Operating Temperature °F(°C)	Inlet / Outlet Connection	Set Pressure psi (bar)	Pressure Range psi (bar)
LCE851-22	550 (38)	-320~165 (-196~74)	1/4 NPT(F)	22 (1.5)	10~150 (0.7~10.3)
LCE851-70	550 (38)	-320~165 (-196~74)	1/4 NPT(F)	70 (5.0)	10~150 (0.7~10.3)
LCE851-140	550 (38)	-320~165 (-196~74)	1/4 NPT(F)	140 (9.7)	10~150 (0.7~10.3)
LCE851-325	550 (38)	-320~165 (-196~74)	1/4 NPT(F)	325 (22.4)	150~350 (10.33~24)

# LCC851 SERIES

Pressure Build/Economizer Regulators

Solutions for Life

## LCC851 Series Combination Pressure Build/Economizer Regulators

A combination of gas maintenance, improved efficiency and prevention of gas loss all in one unit.

- Bonnet and Body: Brass
- Seat: PTFE
- Spring: Stainless Steel
- Diaphragm: PTFE, Phosphor Bronze
- Max. Inlet Pressure: 550 psi (38 bar)
- Working Temperature: -320~165°F (-196~74 °C)
- Conforms to CGA E-4 Standard for Gas Pressure Regulators
- Cleaned for oxygen service per CGA 4.1



### Flow Data

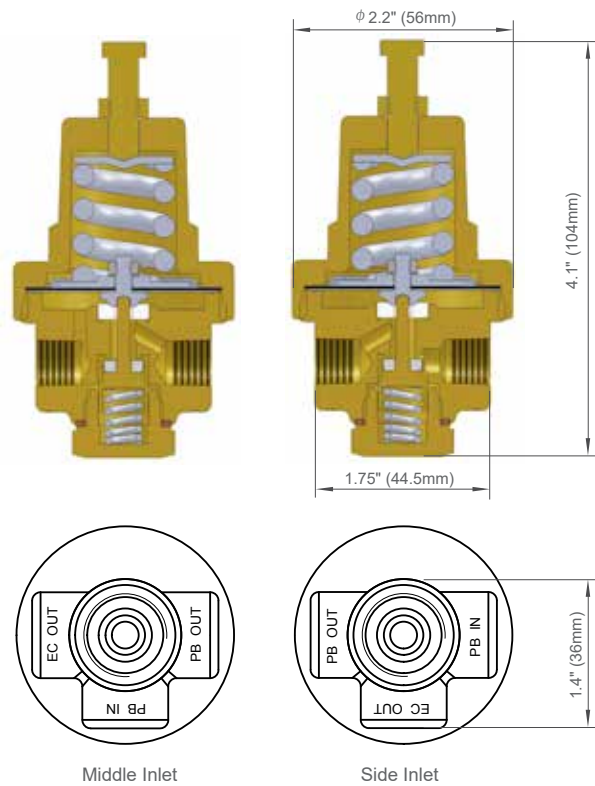
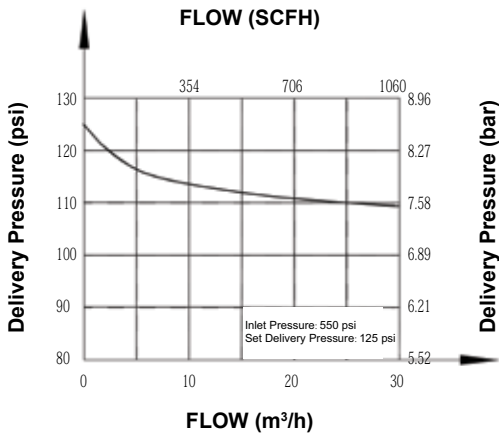

### Ordering Information

Model Number	Maximum Inlet Pressure psi (bar)	Operating Temperature °F (°C)	Inlet / Outlet Connection	Set Pressure psi (bar)	Pressure Range psi (bar)	Remarks
LCC851-22	550 (38)	-320~165 (-196~74)	1/4 NPT(F)	22 (1.5)	10~150 (0.7~10.3)	Side Inlet
LCC851-300	550 (38)	-320~165 (-196~74)	1/4 NPT(F)	300 (21)	150~350 (10.3~24)	
LCC851-325	550 (38)	-320~165 (-196~74)	1/4 NPT(F)	325 (22.4)	150~350 (10.3~24)	
LCC851-22-A	550 (38)	-320~165 (-196~74)	1/4 NPT(F)	22 (1.5)	10~150 (0.7~10.3)	Middle Inlet
LCC851-300-A	550 (38)	-320~165 (-196~74)	1/4 NPT(F)	300 (21)	150~350 (10.3~24)	
LCC851-325-A	550 (38)	-320~165 (-196~74)	1/4 NPT(F)	325 (22.4)	150~350 (10.3~24)	



### 255L Series Heavy Duty Gas Line Regulators

Suitable for high flow gas pipeline and switchover. Built with an internal balance structure and large diaphragm to ensure a large output flow while maintaining a low pressure drop.

#### Features

- Internal Balancing Mechanism
- Brass or High Quality Casted Aluminum Bonnet
- Working Temperature: -40~-140°F (-40~60 °C)
- DN 12.5 connections
- Cleaned for oxygen service per CGA 4.1

#### Materials

- Body: Brass
- Seat: EPDM
- Diaphragm: EPDM



255L-60



255LA-60

#### Flow Data

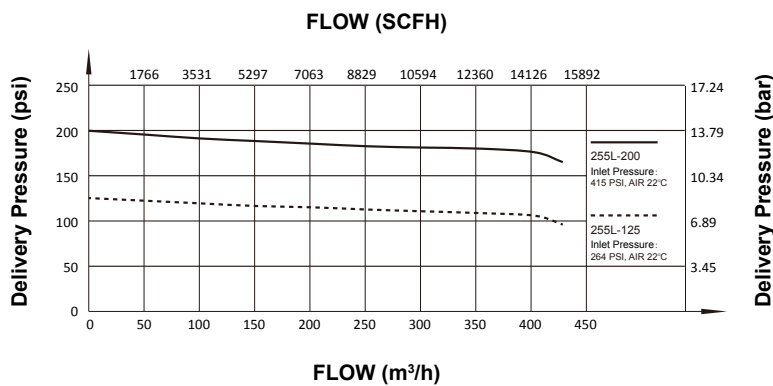

#### Dimensions

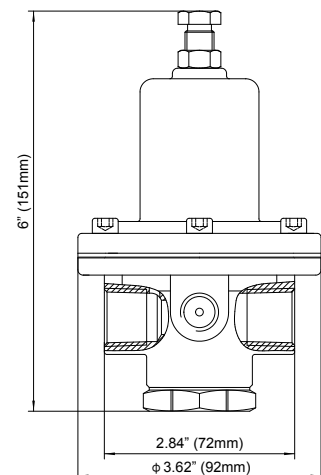

#### Ordering Information

Model Number	Max. Inlet Pressure psi (bar)	Outlet Pressure psi (bar)	Inlet / Outlet Connection	Bonnet Materials
255L-60	500 (35)	5~60 (0.4~4.1)	1/2" NPT(F)	Brass
255L-125	500 (35)	40~125 (2.8~8.6)	1/2" NPT(F)	Brass
255L-200	500 (35)	100~200 (6.9~13.8)	1/2" NPT(F)	Brass
255LA-60	500 (35)	5~60 (0.4~4.1)	1/2" NPT(F)	Aluminum
255LA-125	500 (35)	40~125 (2.8~8.6)	1/2" NPT(F)	Aluminum
255LA-200	500 (35)	100~200 (6.9~13.8)	1/2" NPT(F)	Aluminum

# 853LCR SERIES

Liquid Cylinder Regulators

Solutions for Life

## 853LCR Series Liquid Cylinder Regulators

The 853LCR Series Liquid Cylinder Regulator are specifically designed for gaseous withdrawal of Liquid Oxygen, Carbon Dioxide and Nitrogen cylinders.

Note: Not for use on High Pressure Cylinders.

### Features

- Vapor side application on liquid cylinders or vessels
- 0-125 psi delivery pressure
- 500 psi (34.5 bar) maximum inlet pressure
- Large 2-3/4" stainless steel diaphragm
- High pressure side 500 psi external pressure relief valve
- Forged brass body and housing cap
- Delrin-bushing housing cap for smooth pressure adjustment
- Stem-type seat assembly for more reliable performance
- Sintered bronze inlet filter
- 2-1/2" dual scale outlet gauge
- Conforms to CGA E-4 Standard for Gas Pressure Regulators
- Cleaned for oxygen service per CGA 4.1



### Dimensions

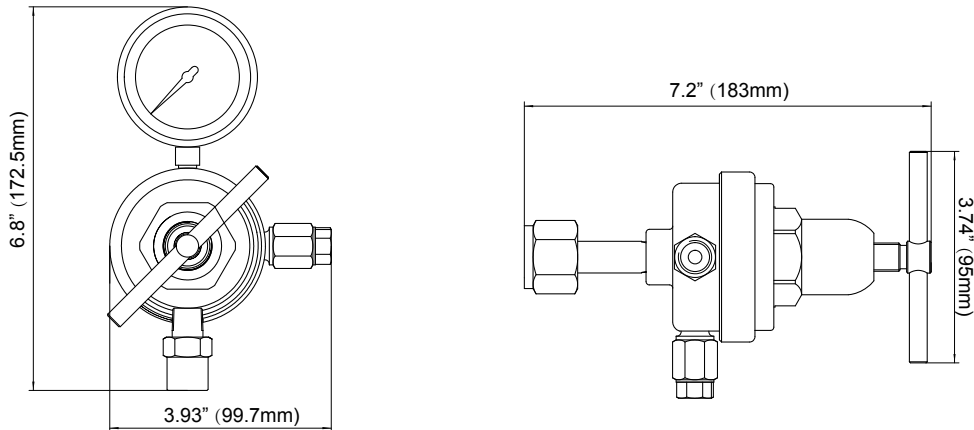

### Ordering Information

Gas Service	Model Number	Maximum Inlet Pressure psi (bar)	Maximum Delivery Pressure psi (bar)	Inlet Gauge	Outlet Gauge	Inlet Connection	Outlet Connection
Oxygen	853LCRX-125	500 (34.5)	5~125 (0.35~8.7)	NONE	2-1/2" , 200 psi	CGA540	9/16"-18RH(M)
Nitrogen	853LCRIN-125	500 (34.5)	5~125 (0.35~8.7)	NONE	2-1/2" , 200 psi	CGA580	5/8"-18RH(F)
Carbon Dioxide	853LCRCD-125	500 (34.5)	5~125 (0.35~8.7)	NONE	2-1/2" , 200 psi	CGA320	5/8"-18RH(F)

### LC856 Series Heavy Duty Gas Line Regulators

The LC856 Series Heavy Duty Gas Line Regulator is designed for final line pressure regulation and suitable for high flow gas distribution systems.

#### Features

- Single-stage construction
- Bonnet and body are made of forged stainless steel
- Operating temperature: -58 ~ 140°F (-50 ~ 60°C)
- Integrated diaphragm configuration ensures no-leak seal
- Internal filter
- Cleaned for oxygen service per CGA 4.1



#### Dimensions

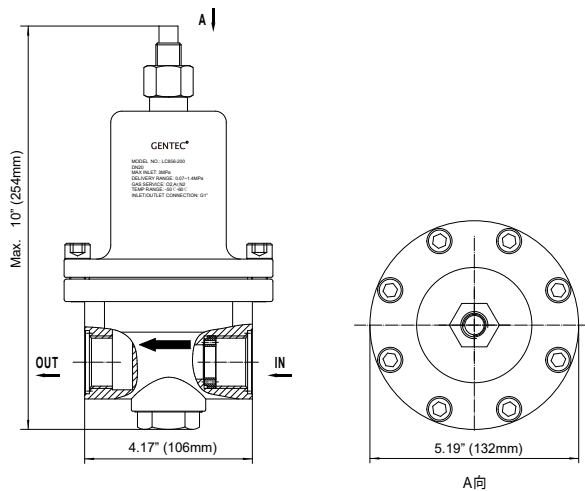

#### Flow Data

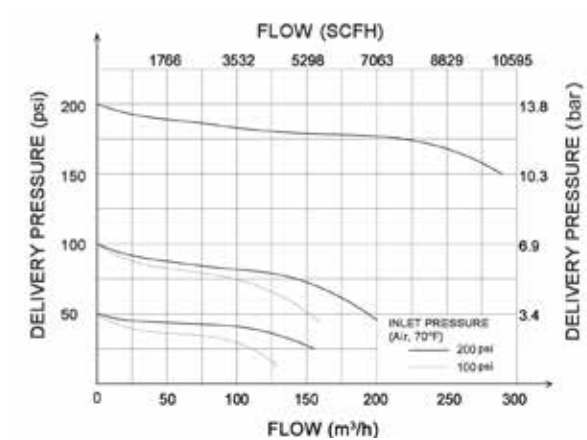

#### Ordering Information

Model Number	Maximum Inlet Pressure psi (bar)	Maximum Delivery Pressure psi (bar)	Inlet Connection	Outlet Connection
LC856-50	435 (30)	50 (3.5)	G 1"	G 1"
LC856-125	435 (30)	123 (8.5)	G 1"	G 1"
LC856-200	435 (30)	203 (14)	G 1"	G 1"

# LCV SERIES

Check Valves

Solutions for Life

## LCV01 Series Check Valves

Suitable for cryogenic liquefied natural gas bottles or other containers, effectively restricts flow in one direction.

### Features

- Gas Service: LNG, LO2, LN2, LAr, Non-corrosive gases
- Suitable temperature: -320 ~ 176°F ( -196 ~ 80°C)
- Opening pressure:  $\leq 5$  psi (0.34 bar)
- Design working pressure: 230 psi (16 bar)
- Max. working pressure: 360 psi (25 bar)
- Nominal diameter: DN=4.7mm
- Inlet / Outlet: 1/8"NPT(M)
- 100% Factory testing reverse sealing
- Cleaned for oxygen service per CGA 4.1



B-LCV01-S-NT2

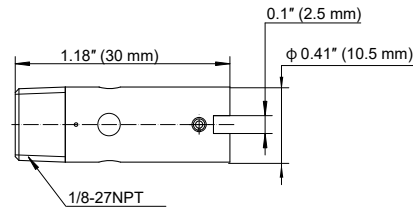

## LCV05 Series Check Valves

Suitable for cryogenic liquefied natural gas bottles or other containers, effectively restricts flow in one direction.

### Features

- Gas Service: LNG, LO2, LN2, LAr, Non-corrosive gases
- Suitable temperature: -320 ~ 176°F ( -196 ~ 80°C)
- Opening pressure:  $\leq 5$  psi (0.34 bar)
- Design working pressure: 230 psi (16 bar)
- Max. working pressure: 870 psi (60 bar)
- Nominal diameter: DN=16mm
- Inlet / Outlet: 1/2"NPT(F), M30\*1.5(M)
- 100% Factory testing reverse sealing
- Cleaned for oxygen service per CGA 4.1



B-LCV 05-T-FNT8



SS-LCV05-T-FT20M-FNT8

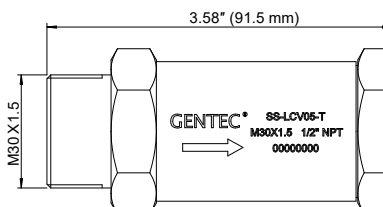
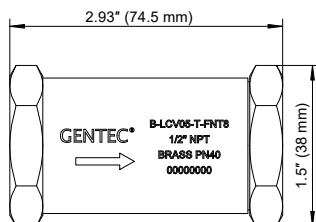

**CRT-R10 Series LNG Nozzle/Quick Disconnect**



CRT-R10



CRT-R10A

**Features**

- Applicable to LNG, LN2, LAr and other cryogenic media
- Made of high quality 316L stainless steel
- Rugged, durable structure
- Easy to install, easy to operate
- Reliable seal designed to effectively prevent leakage during filling
- Cleaned for oxygen service per CGA 4.1

**Dimensions**

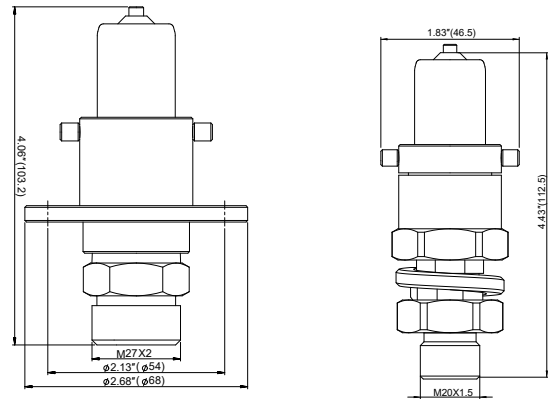

**CRT-R200 Series LNG Receptacle**



**Features**

- Applicable to LNG, LN2, LAr and other cryogenic media
- Made of high quality 316L stainless steel
- Rugged, durable structure
- Easy to install, easy to operate
- Reliable seal designed to effectively prevent leakage during filling
- Cleaned for oxygen service per CGA 4.1

**Dimensions**

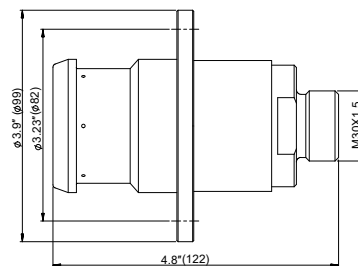



## EV41, EV45 Series Excess Flow Valves

Used in cryogenic liquid cylinders or piping systems to prevent uncontrolled release of cryogenic fluid in the event of a rupture or abnormal excess of flow downstream of the pipeline.

### Features

- Maximum working pressure: 580 psi (40 bar)
- Working temperature: -320~176°F (-196~80°C)
- Cleaned for oxygen service per CGA 4.1
- Suitable for use under pure oxygen environment



EV41

EV45

### Dimensions

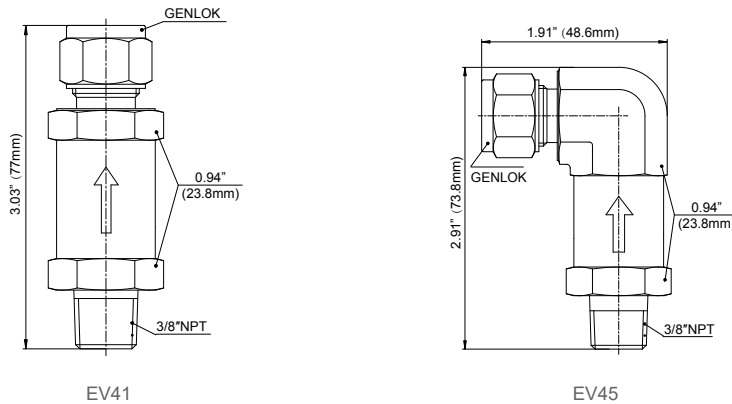

EV41

EV45

### Ordering Information

SS -	EV41 -	NT6 -	TF10M -	M
Body Material	Series	Inlet Connection	Outlet Connection	Flow Options
SS: stainless steel	EV41: Straight Pattern EV45: Angle Pattern	NT6: 3/8" Male NPT	TF10M: 10mm GENLOK TF12M: 12mm GENLOK TF14M: 14mm GENLOK	None Standard Flow M: Medium Flow L: Low Flow

Flow Options	Shut Off The Flow Value L/min	Pressure Difference psi (bar)	Min. Work Pressure psi (bar)
Standard Flow	23.3	40 (2.8)	80 (5.6)
Medium Flow	15	40 (2.8)	80 (5.6)
Low Flow	10	14.5 (1)	29 (2)

Note: The product off the flow value is 15°C water test results  
 If the use of different media, the conversion of  $Q=Q1 \cdot \sqrt{P1/P}$   
 (Q1 is water off the flow value, P1 for water density, Q for medium off flow value, P as medium density)

## GR20B Series Pressure Gauges

For cryogenic applications requiring pressure readings.



### Features

- Brass
- 2" Pressure Gauge
- Temperature: -40~158°F (-40~70 °C)
- Connection: 1/4" NPT
- Back Mount
- Model: GR20B-200, GR20B-400, GR20B-600

### Dimensions

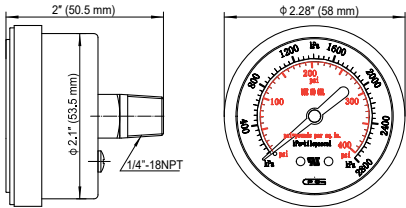

## GR2503 Series Pressure Gauges

For cryogenic applications requiring vibration resistant pressure gauge.



### Features

- Brass plating
- Easy to read 2.5" pressure gauge
- Silicone filled fluid
- Temperature: -58~131 °F (-50~55 °C)
- Connection: 1/4" NPT
- Panel or rear mount options

### Dimensions

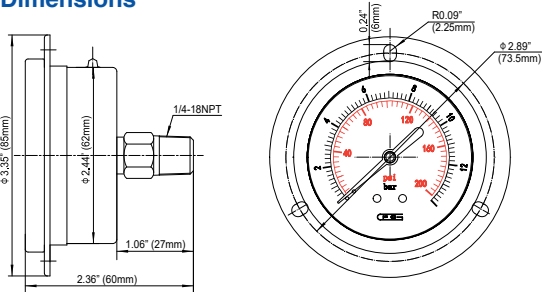

## G5010, GR5010 Series Pressure Gauges

For cryogenic applications requiring vibration resistant pressure gauge.



### Features

- Brass plating
- Easy to read 2" pressure gauge
- Silicone filled fluid
- Temperature: -58~131 °F (-50~55 °C)
- Connection: 1/4" NPT
- Rear or bottom entry connection

### Dimensions

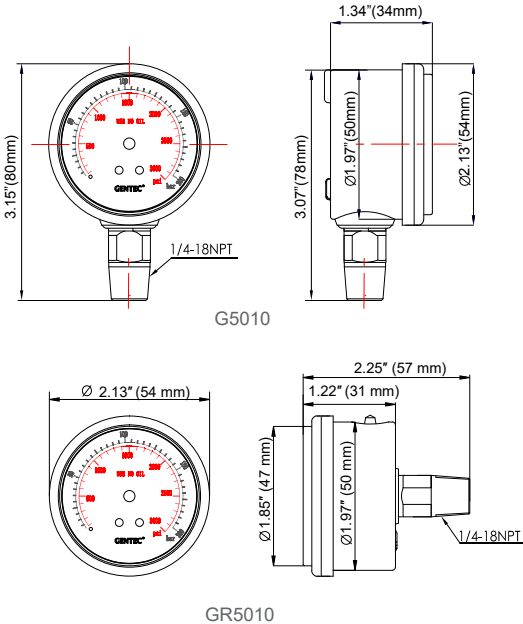



**GENSTAR TECHNOLOGIES COMPANY INC.**

4525 Edison Ave, Chino, CA 91710

Tel: 909.606.2726

Fax: 909.606.6485

[www.gentec.com](http://www.gentec.com)



**GENTEC (SHANGHAI) CORPORATION**

No.499 Wenji Rd.Songjiang District. Shanghai 201616, P.R.C.

TEL: +86 21 67727722

FAX: +86 21 67727754

[www.gentec.com](http://www.gentec.com)

