

GM1 SERIES DOME BIAS SEMI-AUTOMATIC MANIFOLD

GENTEC® GM1 series dome-bias semi-automatic manifold system is designed to provide an uninterrupted gas supply. It consists of a primary bank and a reserve bank of cylinders. When the pressure in the primary cylinder bank reduces to the preset value, the changeover takes place automatically to provide continuous supply of gas from the reserve bank. The priority handle should be manually switched during cylinder change.



Features

Semi-automatic Changeover System

- Fully enclosed, dust-proof metal cabinet
- Pressure gauge indicates gas source and outlet pressure
- Secondary regulator for consistent pressure and flow delivery to the pipeline
- Relief valve at outlet for protecting downstream piping
- Pressure switch port is available
- Mechanical dome-bias changeover design
- Priority Indicator valve
- Suitable for high flow system; rated for 120 m³/h (4200 SCFH)* to 170m³/h (6000 SCFH)**

* When delivery pressure is 50 psi

** When delivery pressure is 180 psi

Pipeline

- Silver brazing on piping joints for maximum leak prevention
- System is designed to accommodate future expansion needs
- Optional external filter provides easy replacement of filter element
- Optional master shutoff valves
- Headers have been tested to withstand high cylinder pressure
- Wall or floor mount available

Series Number	Gas Service	Max. Inlet Pressure psi (bar)	Delivery Pressure psi (bar)	Max. Delivery Flow SCFH (m ³ /h)	Outlet Connection	Inlet Connection
GM1-AL-O ₂	Oxygen	3000 (207)	10~145 (0.69~10)	4200 (120)	3/4" NPT attachment to the union	Pigtail, CGA540
GM1-AM-IN	Inert Gas	3000 (207)	10~230 (0.69~15.86)	6000 (170)	3/4" NPT attachment to the union	Pigtail, CGA580
GM1-AM-CO ₂	Carbon Dioxide	2175 (150)	4.4~125 (0.3~8.62)	1060 (30)	3/4" NPT attachment to the union	Pigtail, CGA320
GM1-AH-AIR	Air	3000 (207)	10~203 (0.69~14)	5300 (150)	3/4" NPT attachment to the union	Pigtail, CGA346

* Connections can be changed to meet DIN, BS or other standards

Specifications

- 24" or 36" flexible high pressure stainless steel braided pigtails with check valve
- Rigid copper pigtails are standard when gas service is oxygen
- Carbon Dioxide manifold systems are provided with H900G electric gas heater
- Siphon-type cylinder should not be used in the manifold system

Dimensions

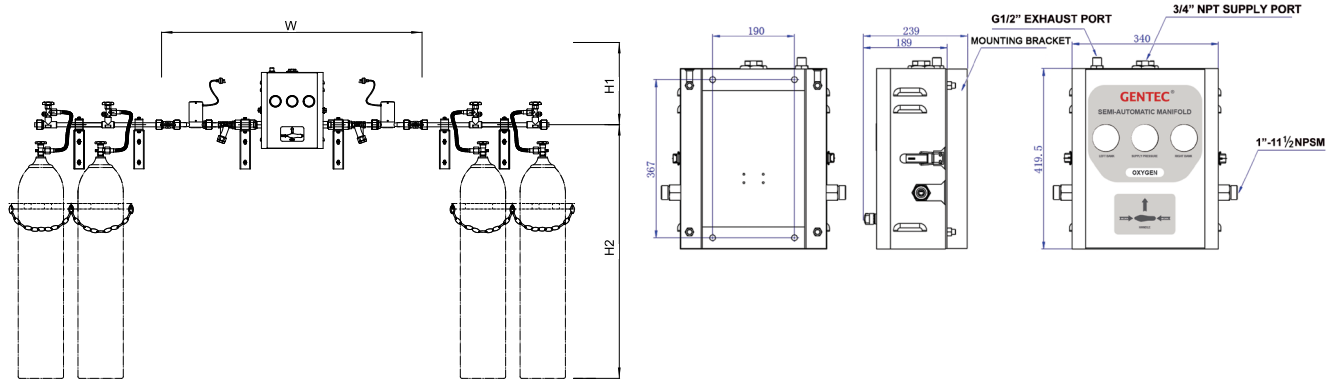

Gas Service	W in.(mm)	H1 in.(mm)	H2 in.(mm)
Oxygen, Air, Argon, Nitrogen, Helium	41.3 (1050)	15.8 (400)	55.1 (1400)
Carbon Dioxide	56.3 (1430)	15.8 (400)	55.1 (1400)

Manifold System Layouts

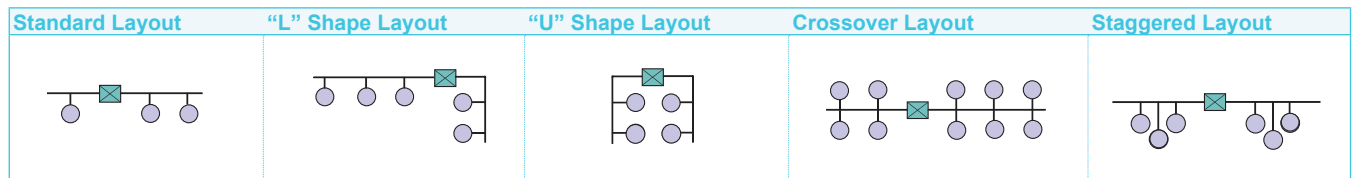

Ordering Information

GM1-A	L		- O2	- U	- (5L - 5R	- S	2)
Series	Delivery Pressure		Gas Service	Color Code	Number of Cylinders	Manifold System Layout	Cylinder Valve Spacing
GM1-A	USA Standard L: 55 psi (380 kPa) M: 100 psi (690 kPa) H: 185 psi (1270 kPa)	EN Standard L: 72.5 psi (5 bar) M: 116 psi (8 bar) H: 145 psi (10 bar)	O ₂ : Oxygen AIR: Air CO ₂ : Carbon Dioxide IN: Ar, He, N ₂	E: ISO 32 U: NFPA 99 (USA)	1L - 2R: One cylinder on the left, Two cylinders on the right 5L - 5R: Five cylinders on the left, Five cylinders on the right 0 - 0: Left and Right side each with filter and master shutoff valve <i>Note: Direction of piping (Right or Left) is indicated while facing the manifold.</i>	S: Standard layout L: "L" Shape layout U: "U" Shape layout D: Crossover layout X: Staggered layout	1: 5" (127 mm) 2: 10" (254 mm) 3: 13" (330 mm) 4: 18" (457 mm)

Example: **GM1-AL-O2-U-(5Lx5R-S2)** indicates a 5*5 oxygen cylinder semi-automatic manifold system. Distance between two cylinders is 10" on standard horizontal layout.
GM1-AL-O2-U-(0x0) indicates an oxygen changeover system with filters and master shutoff valves.
GM1-AL-O2-U indicates an oxygen changeover system only.